

# Hydromechanical power clamping screws \_\_\_\_\_ Series HSP

- high clamping forces with low tightening torques
- large clamping stroke - with mechanical safety devise

## Design and function

The hydromechanical power clamping screw type HSP is single acting for external clamping operation (shafts, rollers, etc.). The force i. e. pressure is generated by compression of a confined oil volume with the primary piston. The force magnification results from the surface ratio between the primary and secondary piston. By turning the drive spindle in the right hand direction (clockwise), the primary piston makes a linear motion compressing the oil within the confined area. The oil pressure thus generated acts over the larger surfaces of the secondary piston and pushes the threaded spindle with the mounted jaw against

the workpiece to be clamped. A clamping force is generated proportionally to the actuation torque applied. The clamping stroke can be read of the clamping stroke indicator. After completion of the clamping procedure the clamping screw should be secured against overload by means of the mechanical safety devise (adjusted gear wheel), which at the same times helps to achieve a high degree of stiffness. A high value of stiffness is also achieved due to the direction force transfer into the supporting bearing.

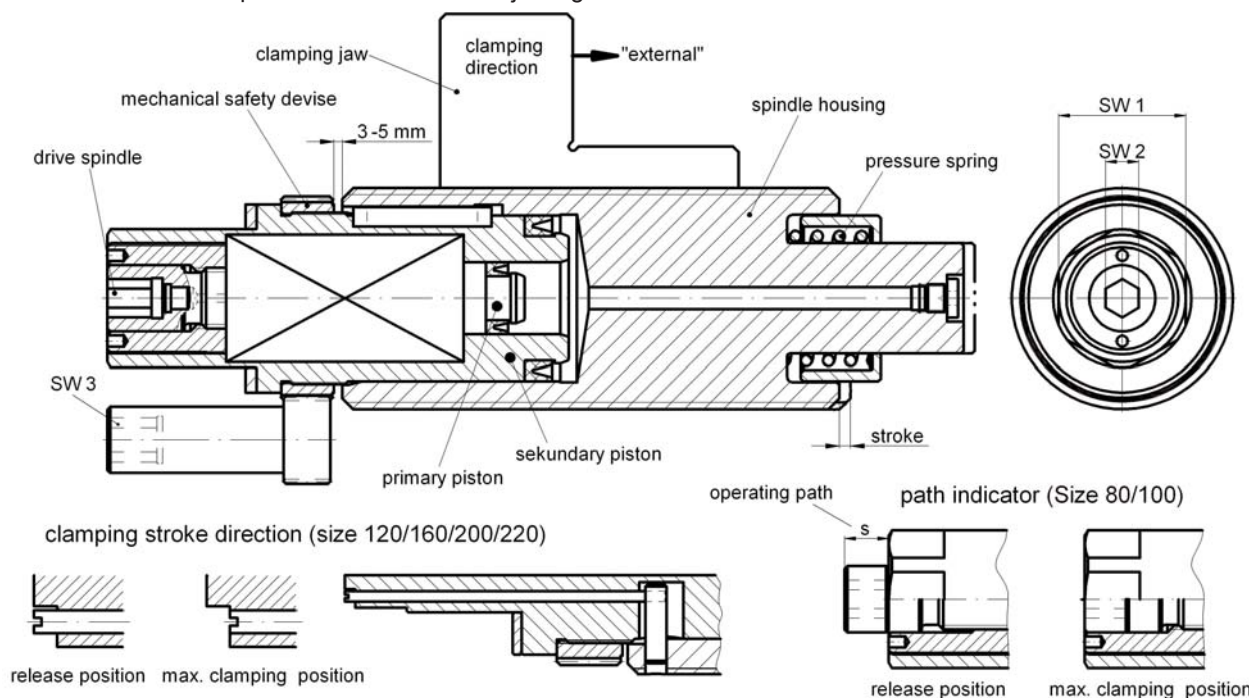

## Operating Clamping

The clamping jaw approaching the workpiece is prealigned and pretensioned by turning the external hexagon SW 1 with the aid of a ring or socket spanner in clockwise direction. A torque wrench should be used for force clamping and fine adjusting. The clamping force is proportional to the internal oil pressure which in turn is dependant on the actuation torque applied. In step 2 the clamping force is generated by turning the hexagon socket SW 2 in the right hand direction (clockwise) with a torque wrench. The required clamping force is

attained when the torque wrench slips at the preset value (refer clamping force diagram). In order to prevent damage due to overload the maximum tightening torque as specified must not be exceeded. If the full clamping stroke is used up an inner stop is reached, and the torque wrench disengages without generating the required clamping force. A motion proportional to the clamping stroke is made by the position indicator which is visible in the window next to the hexagon socket SW 1.

## Safety precaution

To safeguard against the possible loss of hydraulic pressure and the same time increase the overall stiffness a mechanical safety devise (adjustig gearwheel) is used. By turning the hexagon socket SW 3 to the right (clockwise) and adjustable gear - wheel is operated over a pinion shaft and engaged with the gear on the screw (see above sketch) housing. The

safety measure ensures that in the case of a drop in pressure eg. due to leakage in the system the over clamping screw is still secured. The static load is directly transmitted to the supporting bearing. The pinion shaft SW 3 is not within the scope of supply.

## Unclamping

By turning the hexagon socket SW 3 to the left (anti clockwise) the mechanical safety devise is released. Should the turning back of the gear be very difficult, then the pressure of the hydraulic system should be increased by first turning the hexagonal allowing to be loosened. After that the clamping

jaw can be moved by turning the hexagon socket SW 1 anticlockwise with a ringspanner. The compression spring, exerts a continuous thrust on the hydraulic system, as well as exerts a return motion on the power clamping screw and jaw during the unclamping operation.