

Speziell für SPINNER CNC-Drehmaschinen entwickelter Stangenlader
Specially for SPINNER CNC-Lathes designed bar-loading Magazin

- ◆ Kompakt
- ◆ Schnell
- ◆ Kostengünstig

- ◆ Compact
- ◆ Quick
- ◆ Low Cost



- ◆ CNC-Servoachse für Nachschub
- ◆ Nachschublänge programmierbar
- ◆ Kein Anschlag im Revolver nötig
- ◆ Einfache Bedienung

- ◆ CNC-servo axis for bar pusher
- ◆ Pushing length programmable
- ◆ No stopper in turret needed
- ◆ Simple programming



| | | Servo 80-1200 | Servo 80-1500 | Spindelverlängerung Spindle extension | | |
|-----------|---------------------|-------------------|----------------|--|----|--------------------|
| Allgemein | Materiallänge max. | mm 1200 | 1500 | 300 | mm | Material length |
| | Materialdurchmesser | mm 6-80 | 6-80 | 6-60 | mm | Material diameter |
| | Masse | kg 350 | 380 | 120 | kg | Weight |
| | Abmessungen (LxBxH) | mm 1880x1224x1125 | 2180x1224x1125 | 400x400x1100 | mm | Dimensions (LxWxH) |



Barload

- ◆ Bis 3,2 Meter Materiallänge
- ◆ Öldurchflutet
- ◆ Ruhiger Lauf
- ◆ Automatischer Stangenwechsel

- ◆ Up to 3,2 meter length of material
- ◆ Oil filled
- ◆ Smooth running
- ◆ Automatic bar-load

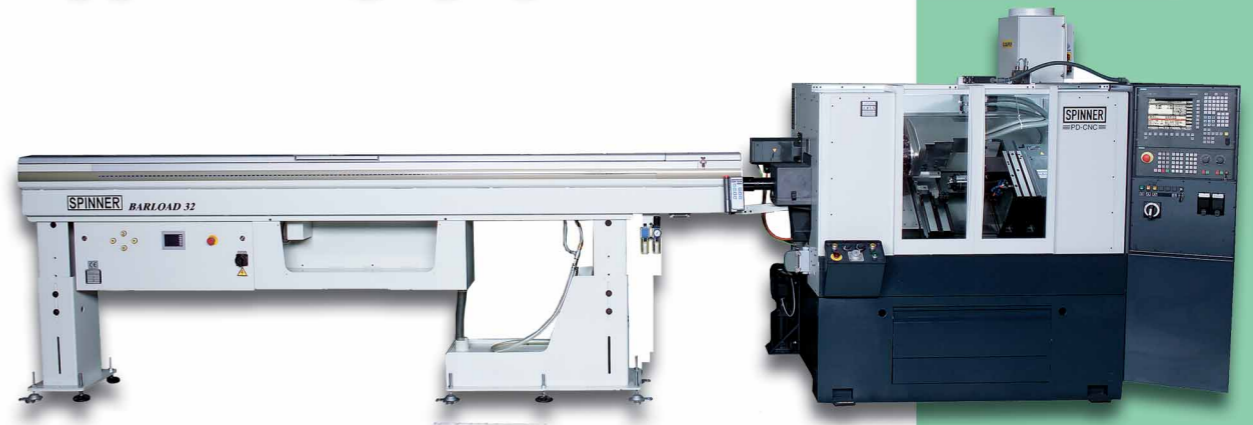
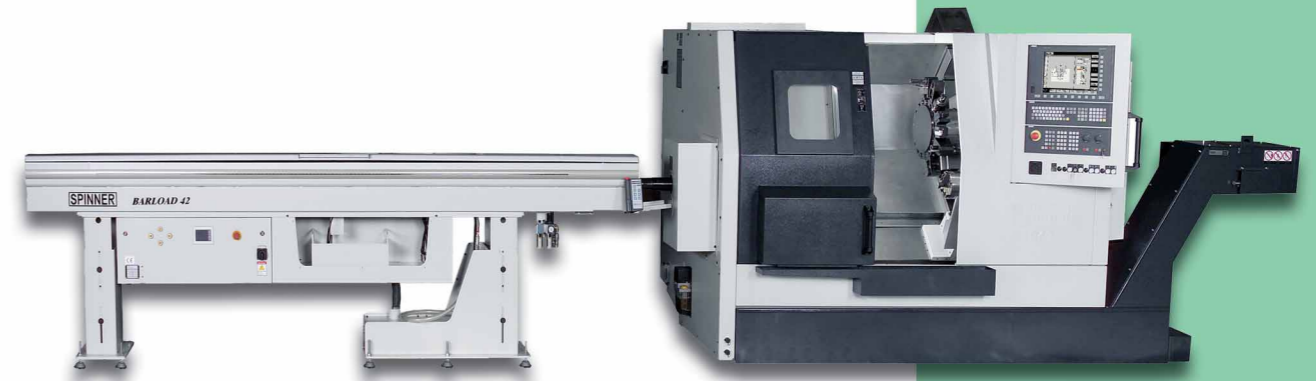

| | | Barload 32 | Barload 42 | Barload 52 | | |
|-----------|---------------------|------------|--------------------------|------------|------|-----------------|
| Allgemein | Materiallänge max. | mm | 3200 | | mm | Material length |
| | Materialdurchmesser | mm | 4-32 | 4-42 | 5-52 | mm |
| | Masse | kg | | 760 | | kg |
| | Abmessungen (LxBxH) | mm | 3910 x 480 x 1090 – 1490 | | | mm |

Automation Automation

Die einfachste Automation
Ihrer Drehmaschine

*The most simple automation
of your lathe*

