

# Metal bellows coupling I Series KPS

- /// 4-corrugation bellows // short design // simple installation with radial EASY-clamping hub
- /// for direct mounting in a hollow shaft // internal axial buffer

## Technical data:

KPS size	$T_N$ [Nm]	moment of inertia [ $10^{-3} \text{kgm}^2$ ]	torsional stiffness [Nm/arcmin]	max. shaft displacement (mm)		axial spring rate [N/mm]	lateral spring rate [N/mm]	mass approx. [kg]	tightening torque of screws f/i [Nm]
				axial $\pm$	lateral				
2	2	0,01	0,4	0,25	0,1	32	100	0,03	2
8	8	0,02	1,9	0,5	0,15	20	90	0,1	8
20	20	0,13	7	0,5	0,2	70	480	0,3	14
60	60	0,28	13	0,6	0,2	70	650	0,4	35
170	170	0,94	27	0,8	0,2	100	1000	0,8	65
400	400	1,95	64	0,7	0,2	135	1500	1,4	115
600	600	4,1	107	0,7	0,2	145	3000	2,6	185/115

Temperature range: -40°C up to +300°C

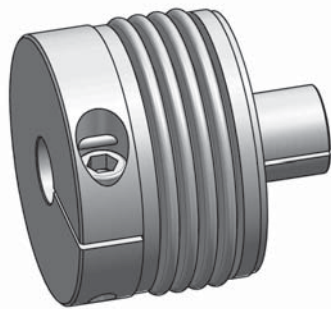

Material:  
 bellows: stainless steel  
 hubs: high tensile strength aluminium  
 expanding cone: heat treated steel  
 screws: DIN 912 - nickel plated

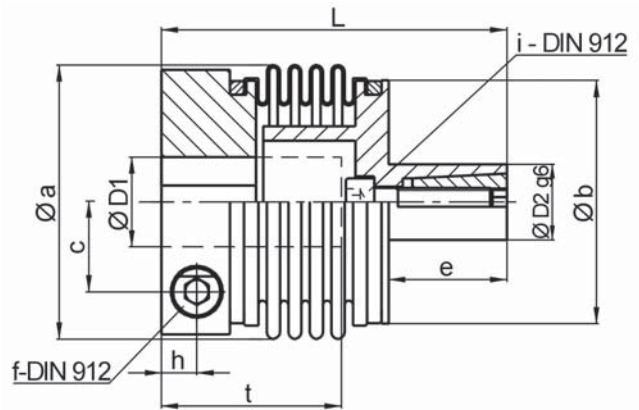

Dimensions [mm]: length dimensions according to DIN ISO 2768 cH

KPS	$\varnothing a$	$\varnothing b$	c	e	f/i	h	L	t <sub>min</sub>	t <sub>max</sub>	$\varnothing D1$		$\varnothing D2$	
										min	max	min	max
2	24,5 (27,5)	22	7,5	10	M 3	4,5	38	12	20	3	10 (14)	8	12
8	39,5 (44,5)	35	13	20	M 5	6	61	15,5	33	6	19 (21)	13	18
20	56	51	19	25	M 6	7,5	73	19	38	9	30	15	20
60	66	61	22	26	M 8	8,5	78	21	40	18	34	20	28
170	82	77	28,5	30	M 10	10,5	92	25	48	22	43	25	32
400	101	95	35	32	M 12	12	102	28	56	34	55	30	38
600	122	110	43,5	42	M 14/12	13,5	118	31	63	35	70	35	48

Notice: The associated bore size for the expanding cone  $> \varnothing D2 \text{ g6} <$  with tolerance H7.  
 Sizes KPS 2 and KPS 8 without EASY-clamp.

application example: Integrated design of a KPS coupling

Ordering example: KPS 20 - D1 = 15<sup>H7</sup> - D2 = 20<sub>g6</sub>

