

Safety coupling I Series SKB - KS for direct drives

- ✓ with bellow attachment for direct drives
- ✓ with clamping hub - bellow side with conical clamping hub
- ✓ compensations of misalignments - low restoring forces

Technical data:

SKB -KS Size	static disengagement torque T_{KA} [Nm]	moment of inertia $[10^{-3} \text{kgm}^2]$	mass approx. [kg]	torsional stiffness [Nm/arcmin]	max. shaft displacement [mm]		tightening torque of screws „j“ [Nm] „i“ [Nm]		$\varnothing D1$ min max		$\varnothing D2$ min max	
6	2 - 6	0,13	0,5	2,1	0,5	0,15	M4 [3]	M5 [10]	6	15	5	16
12	6 - 12								6	15	8	16
15	8 - 15	0,5	1,1	9	0,5	0,2	M4 [4]	M6 [18]	9	19	10	25,4
30	13 - 30								9	19	12	25,4
45	22 - 45								10	19	14	25,4
60	25 - 60	1,5	2,1	20	0,6	0,2	M6 [14]	M8 [40]	12	25	18	35
100	40 - 100								12	25	18	35
150	60 - 150								14	25	24	35
230	80 - 230	5,6	4,4	28	0,8	0,2	M6 [14]	M10 [80]	18	35	24	44
330	130 - 330								22	35	32	44
500	200 - 500	15	8	52	0,8	0,2	M8 [34]	M14 [220]	26	42	28	58
800	350 - 800	17	9	106	0,7	0,2	M10 [65]	M14 [220]	32	48	40	58
1000	500 - 1000	82	21,5	80	1	0,3	M10 [65]	2xM16 [290]	40	60	42	100
2000	800 - 2000	91	23	140	1	0,3	M12 [115]	2xM16 [290]	42	70	45	100
3000	1500 - 3000	96	25	260	1,4	0,2	M12 [115]	2xM16 [290]	48	70	60	100

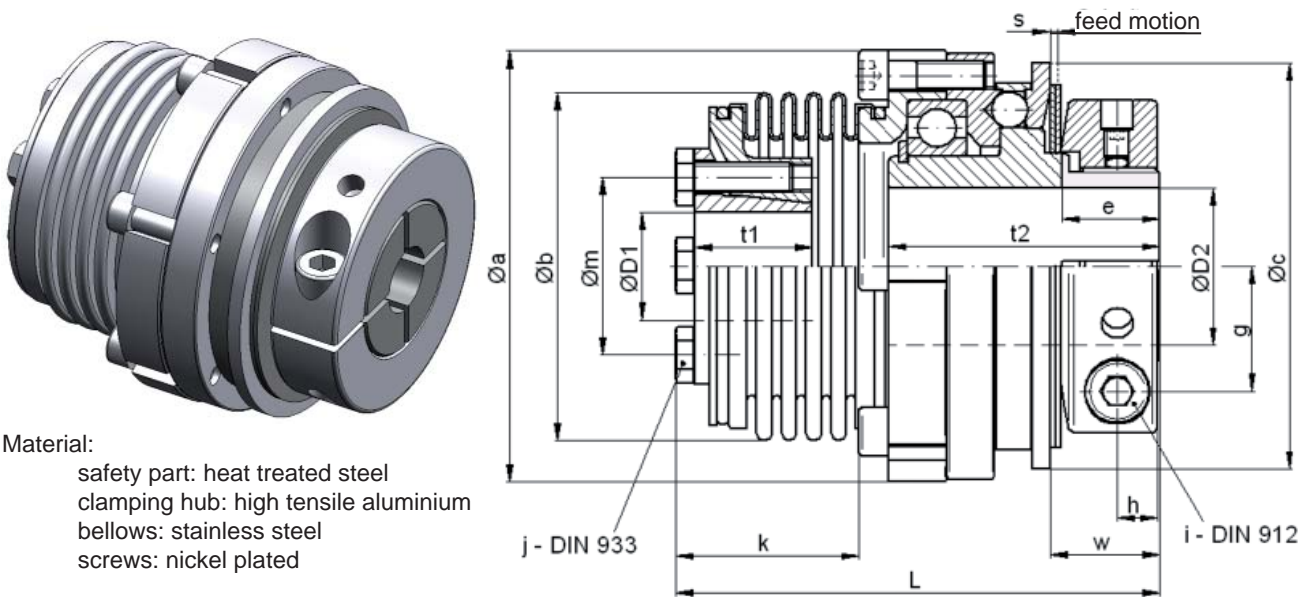

Material:

- safety part: heat treated steel
- clamping hub: high tensile aluminium
- bellows: stainless steel
- screws: nickel plated

Dimensions [mm]: length dimensions according to DIN ISO 2768 cH

SKB - KS	$\varnothing a$	$\varnothing b$	$\varnothing c$	e	g	h	k*	$L \pm 1$	$\varnothing m$	s	t1	t2	w
6/12	52,5	39,5	48	14	13,5	6	45	89	27	0,9	21	41	16
15/30/45	69	56	66	16	19,5	7,5	34,8	86	30	1,2	18	48	18,5
60/100/150	88	71	83	20	25,5	8,5	37,5	99	36	1,6	24	55,5	22
230/330	115	82	109	23	32	10,5	40	120	50	1,8	27	72	26
500	137	101	132	32	42	13,5	45	141	62	2,5	32,5	87,5	37
800	137	122	132	32	42	13,5	60	156	70	2,5	36	87,5	37
1000	181	132	185	74	69	17/30	85	218	83	3,7	44	124	74
2000/3000	181	157	185	74	69	17/30	88,5	222	98	3,7	45	124	74

* Notice: Alternative length of bellows are possible on request.

Ordering example: SKB - KS 30 - D1 = $\varnothing 18$ ^{G7} - D2 = $\varnothing 24$ ^{H7} - $T_{KA} = 25$ Nm