

- optimum overload and crash protection for direct drives
- with coupling attachment - system construction cit with numerous variants
- simple installation, frictional shaft - hub connection
- kompact design - low moment of inertia

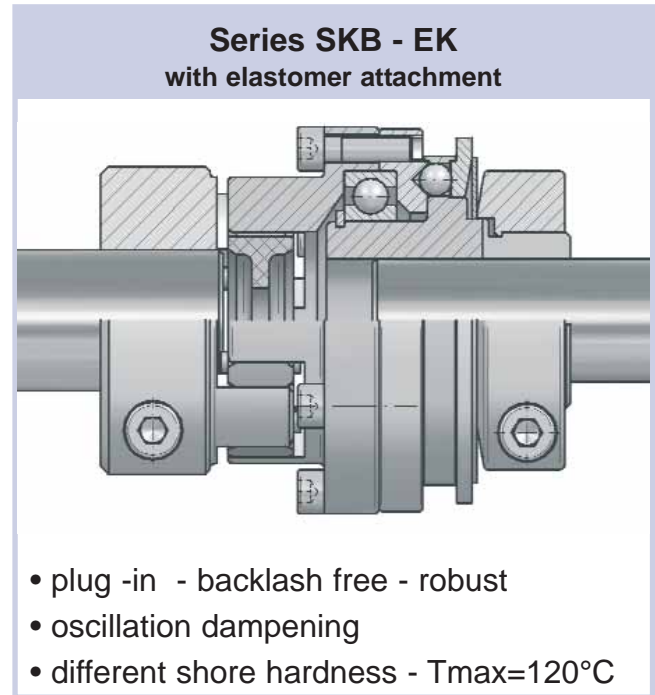
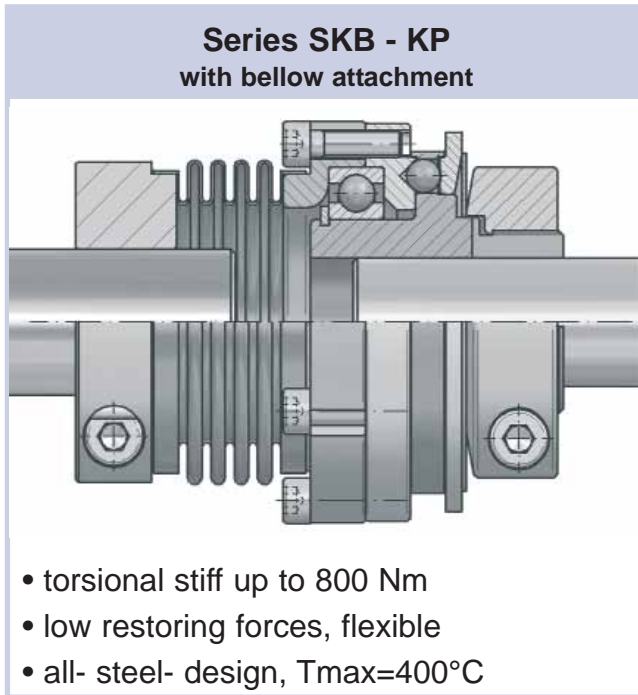

**Following Safty Couplings series for direct drives are available:**

**Series SKB-KP** → with 4- corrugation metal bellow / with easy to fit radial clamping hub

**Series SKB-KSD** → with 4- corrugation bellow / with conical bushing for small shaft diameters

**Series SKB-EK** → with elastomer spider - 98 ShoreA / with plug in, radial clamping hub

**Series SKB-ES** → with elastomer spider - 98 ShoreA / with plug in, conical hub

Note: Safety couplings general with clamping hub; other variants on request.

**Application examples:**



Collusion protection of a drive spindle with safty coupling series SKB with bellow attachment

Safty coupling series SKB with elastomer attachmnet for overload protection of a planetary gearbox.

