

Safety Couplings I *for indirect drives*

- ✓ for the attachment of toothed belt pulleys, gear wheels, chain wheels, flanges, and so on
- ✓ with integrated ball bearing or sliding bearing - for optimal constructional adjustment
- ✓ frictional shaft-hub-connection with conical clamping bush or conical clamping ring

For overload protection or as collision protection for indirect drives, JAKOB's standard program presents series SKB, SKY, SKW and SKG with integrated ball bearing, as well as series SKX-L with integrated sliding bearing. The flange rings can be attached to gear wheels or other units with an axial run-out accuracy of a few hundredths of a millimeter. During normal operation, the bearings must take up the radial and axial forces and transfer them to the drive or output shaft. Only during uncoupling, there is a relative rotational movement between flange ring and hub for a short time. The torque is transferred without backlash and frictionally from the shaft to the coupling hub by a conical clamping ring or a conical clamping bush.

The SKB coupling can be used for big pulleys and pinions because of the reference diameter of the fastening threads, the SKX-L series is made for longer attachment parts with small diameters. The series SKG with its integrated ball bearing provides a good alternative for very compact solutions. To achieve this, the coupling body can almost be completely fit into the pulley with the result, that the forces can be led almost centrally into the bearing. Furthermore, the clamping ring is located on the inside, at the side of the shaft, and therefore a subsequent mounting (modification) is possible, even when available space is limited. Other safety coupling series for indirect drives, such as series SKM with separate sliding bearing or series SKD with blocking mechanism can be delivered upon special request.

Series SKB

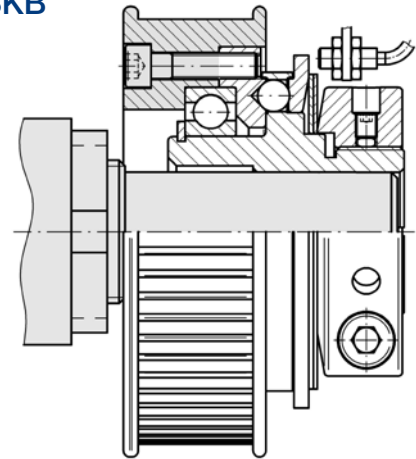

Series SKY

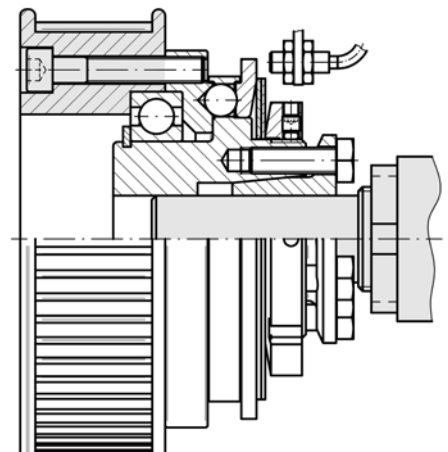

Series SKX-L

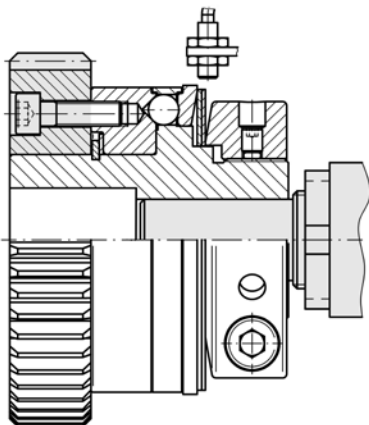

Series SKW

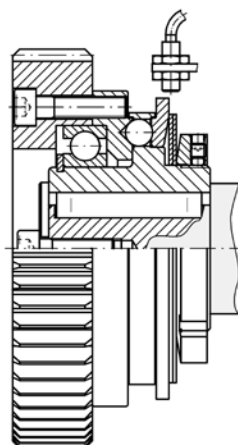

Series SKG

