

# HOME OF CLAMPING



**CATALOGUE 2026**



**2026**  
STANDARD CLAMPING ELEMENTS

## WE GENERATE EXCITEMENT.

Since the foundation of the company in 1890 until today the goal has remained the same: the highest quality in products and services. Nevertheless, the circumstances, tasks and challenges have changed, of course. By focussing on our core areas of expertise, we have long set new standards for innovative clamping technology - driven by our own development, the greatest possible flexibility and passion for individual solutions.

All this is only possible with committed and contented employees. Respectful interaction with others, personal development and measures for the wellbeing of each individual are therefore values that matter to us.



Company Management:  
Wolfgang Balle, Johannes Maier (CEO), Jürgen Förster

## OUR COMPANY HISTORY

- 1890 Company founded as a lock manufacturer by Andreas Maier.
- 1920 Product range extended to include spanners.
- 1928 Production line assembly of FELLBACH LOCKS.
- 1951 Introduces clamping elements and diversifies into workpiece and tool clamping technology.
- 1965 Toggle clamps extend the AMF product range, AMF catalogues are now printed in ten languages.
- 1975 Further specialisation into hydraulic clamping technology.
- 1982 Clamping and fixture systems round off AMF's clamping expertise.
- 1996 AMF team organisation in all sectors of the business, Quality management with certification to ISO 9001.
- 2001 AMF Service Guarantee for all products.
- 2004 Introduction of the ZPS zero-point clamping system.
- 2007 The magnetic clamping technology extends the AMF product range.
- 2009 Development and marketing of AMF Vacuum clamping technology.
- 2012 LOW-COST AUTOMATION gripping, clamping, marking and cleaning.
- 2014 AMF presents the most extensive product range of automation solution in zero-point clamping technology.
- 2017 Wireless sensing systems extend the expertise into Industry 4.0 and blends seamlessly into the AMF product range.

## PLEDGES THAT COUNT IN EVERYDAY LIFE

For this reason, we have a few principles that we follow by conviction and which always apply.

### INDIVIDUAL DEVELOPMENT

Even if the product you need does not even exist yet, we will find the right solution with you: from special designs to new developments, everything is possible.

### WARRANTY

If, despite our high quality standard, there is a complaint, this is dealt with quickly and unbureaucratically, even beyond the warranty period.

### HIGHEST QUALITY STANDARDS

Careful manufacturing based on tradition since 1890, and naturally with a modern quality management system according to ISO 9001 for many years.

### SHORT DELIVERY TIME

With over 5,000 articles in our warehouse, you can expect your order to be dispatched on the same day.

### COMPETENT SERVICE FROM EXPERTS

Your local retail partner or the specialists in our team will find the right solution for every task.

### MADE IN GERMANY

Our entire product range is developed and manufactured exclusively by our employees in Germany.

<b>POWER CLAMPS, COMPACT CLAMP</b>		<b>6 - 20</b>
<b>CLAMPS</b>		<b>21 - 47</b>
<b>SUPPORT BLOCKS</b>		<b>48 - 52</b>
<b>SETTING ELEMENTS MANDREL AND FLOATING CLAMPS</b>		<b>53 - 90</b>
<b>CLAMPING BOLTS, NUTS AND WASHERS</b>		<b>91 - 113</b>
<b>CLAMPING SETS AND ACCESSORIES</b>		<b>114 - 122</b>
<b>PULL-DOWN CLAMPS</b>		<b>123 - 139</b>
<b>POSITIONING ELEMENTS</b>		<b>140 - 159</b>
<b>STOPS AND PRECISION T-NUTS</b>		<b>160 - 163</b>
<b>CENTRING CLAMPS AND ECCENTRIC CLAMPS</b>		<b>164 - 166</b>



**SWIVELLING ATTACHMENT SMOOTH WITH +/- 3° ANGLE FUNCTION**

6440GS, page 80



**POWER CLAMP**

7600, page 7  
NEW SIZE!



**MANDREL**

6417, page 84

**NEW!**

**SWING CLAMP, MECHANICAL**

7650, page 16



**NEW!**

**SWING CLAMP, MECHANICAL, MODULAR**

7651, page 18



**ALUMINIUM SCREW JACK WITH CHIP GUARD PLATE AND ALUMINIUM BASE OR MAGNETIC BASE**

6406A-88, 6406M-88, page 70



**SIDE CLAMP WITH CLAMPING POINT**

6472, page 135



**SCREW JACK SET**

6400-285, page 64

## NOT ONLY INCREDIBLE IN TERMS OF USE - OUR MODULAR SCREW JACK ALSO BOASTS AN IMPRESSIVE PRODUCT DESIGN.

Andreas Maier GmbH & Co. KG (AMF) has won an international design award. In the capital goods/tools category, our flexible, modular screw jack was able to convince the jury.



Focus Open 2020  
Gold

TAKE A LOOK AT OUR  
PRIZE WINNER!  
MORE FROM PAGE 54 ...



## THE POWER CLAMP THAT KEEPS ITS PROMISES

- > **Uses:** All clamping tasks in cutting and non-cutting finishing operations. There are no limits to the possible uses in tool-making, injection moulding, presses and die-cutters as well as in model- and mould-making.
- > **Characteristics:**
  - > Clamping force up to 22 kN or 60 kN
  - > Low installation height
  - > Fast and simple clamping possible
  - > Continuously adjustable

When using clamps in non-cutting and cutting metal finishing processes, as well as in mould making, clamping force and precision that meet the highest demands are required. With the sliding power clamp made of alloyed tempered steel, we offer an exceptionally robust and versatile mechanical clamping element, which can achieve extremely high clamping force of up to 60 kN.

The power clamp, which is usable both horizontally and vertically, can be fastened to regular T-slot tables using T-nuts or, alternatively, to grid pallets using threaded mounting.



## No. 7600

### Power clamp

Continuously adjustable clamping element made of alloyed tempered steel in forged, black galvanised design. Complete with mounting kit 7600BFS.  
Thrust piece in smooth and ribbed variant, optionally available.



Order no.	Size	max. load static [kN]	M	Slot	H	E	L	Weight [g]
562184	22	22	M10	12	5 - 38	19 - 54	65	700
556406	22	22	M12	14	5 - 38	19 - 54	65	700
556186	30	30	M12	14	6 - 68	20 - 110	135	2013
556187	30	30	M16	18	6 - 68	24 - 113	135	2045
556189	32	32	M12	14	6 - 50	20 - 82	95	1462
556190	40	40	M16	18	6 - 55	25 - 94	110	2262
556188	43	43	M16	18	6 - 80	29 - 134	155	3158
563656	44	44	M18	20	7 - 88	36 - 165	176	5880
554198	49	49	M20	22	7 - 88	36 - 165	176	5928
564654	60	60	M24	28	8 - 102	63 - 180	203	8950
572092	60	60	M30	36	8 - 102	45 - 163	203	9512

**NEW!**

### Application:

1. Position carrier element on the tool table and secure with the specified tightening torque Md.
2. Move the clamp arm to the desired position.
3. Moving the adjusting screw clamps the workpiece.

### Advantage:

- Low installation height
- High clamping force of 22 - 60 kN
- Height and length continuously adjustable
- The very robust design enables quick and easy clamping
- Elements easy to install
- For use in T-slots 12 - 36 mm and/or grid plates M10, M12, M16, M18, M20, M24, M30
- 2 thrust piece variants

### Note:

- The max. load may differ, depending on the manner of clamping and condition of the threads (lubrication).
- To reduce the wear on the adjusting screw, we recommend the use of AMF screw compound no. 6339. It has a synergistic combination of highly effective solid lubricants, is heat-resistant, and cannot be washed out.
- Use only the corresponding AMF mounting kit 7600BFS.
- If the clamping element without T-slot nut DIN 508 is used, the tensile strength of the support plate must be at least 900 N/mm<sup>2</sup>!
- Sizes 30 M16 / 44 M18 / 60 M24 and 60 M30 are not suitable for use with no. 7600Z.

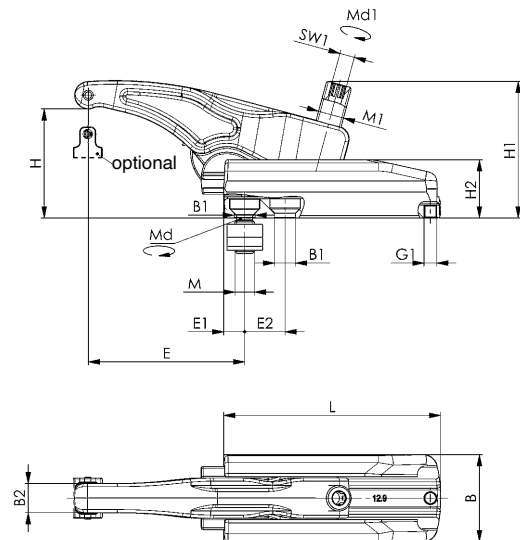

### Dimensions:

Order no.	Size	Max. load, dynamic swelling [kN]	B	B1	B2	E1	E2	G1	H1	H2	M1	SW1	Md 1 [Nm]	Md [Nm]
562184	22	17	45	13	13	11	-	M6	58	30	M12	6	50	35
556406	22	17	45	13	13	11	-	M6	58	30	M12	6	50	40
556186	30	23	54	13	18	13	25	M8	85	36	M16	8	100	70
556187	30	23	54	17	18	16	28	M8	85	36	M16	8	100	150
556189	32	24	54	13	18	12	20	M8	78	36	M16	8	100	70
556190	40	31	59	17	20	15	26	M8	92	42	M20	10	150	150
556188	43	32	59	17	20	16	32	M8	105	42	M20	10	150	150
563656	44	34	75	21	25	20	36	M10	125	52	M24	12	180	160
554198	49	38	75	21	25	20	36	M10	125	52	M24	12	220	200
564654	60	45	90	24,5	30	23	45	M10	143	57	M24	12	300	280
572092	60	45	90	30,5	-	26	-	M10	143	57	M24	12	300	280

**NEW!**

Subject to technical alterations.



## No. 7600Z

### Spacer element

Made of alloyed tempered steel in forged, black galvanised design. Complete with mounting kit.



GERMAN DESIGN AWARD SPECIAL 2017



Order no.	Size	M	Slot	H	H2	L	Weight [g]
562185	22	M10	12	40 - 73	35	65	480
556407	22	M12	14	40 - 73	35	65	480
554821	30	M12	14	66 - 128	60	135	2300
554822	32	M12	14	66 - 110	60	95	1570
554823	40	M16	18	76 - 120	70	110	2290
554824	43	M16	18	75 - 150	70	155	3344
554825	49	M20	22	87 - 168	80	175	5286

### Advantage:

- Additional clamping heights can be achieved by installing multiple spacer elements
- Continuous transition between the clamping heights
- For use in T-slots 12 - 28 mm and/or grid plates M10, M12, M16, M20

### Note:

- Use only the corresponding AMF mounting kit 7600BFS.
- If the clamping element without T-slot nut DIN 508 is used, the tensile strength of the support plate must be at least 900 N/mm<sup>2</sup>!

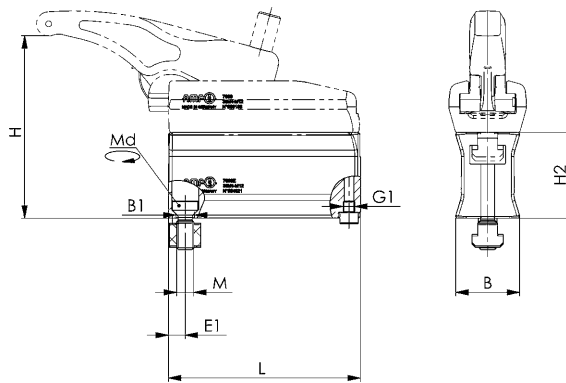

### Recommendations



No. 6339, page 119

### Dimensions:

Order no.	Size	B	B1	E1	G1	Md [Nm]
562185	22	36,0	13	12	M6	35
556407	22	36,0	13	12	M6	40
554821	30	44,5	13	12	M8	70
554822	32	44,5	13	12	M8	70
554823	40	47,5	17	16	M8	150
554824	43	47,5	17	16	M8	150
554825	49	58,0	21	19	M10	200

CAD



## No. 7600BFS

### Mounting kit

comprising flat-head screw strength class 12.9 and T-nuts DIN 508.

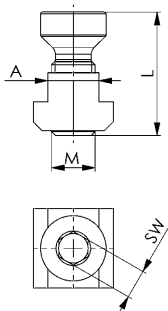

Order no.	Size	A	L	M	SW	Weight [g]
562186	22	12	29,0	M10	6	61
556576	22	14	31,5	M12	6	61
556152	30 / 32	14	34,0	M12	8	70
556153	30 / 32	16	38,0	M12	8	98
556154	30 / 32	18	38,0	M12	8	125
556155	30	18	41,0	M16	8	143
556156	30	20	45,0	M16	8	208
556157	30	22	49,0	M16	8	270
556158	30	24	49,0	M16	8	348
556159	40 / 43	18	43,0	M16	10	145
556160	40 / 43	20	47,0	M16	10	195
556161	40 / 43	22	51,0	M16	10	264
556162	40 / 43	24	51,0	M16	10	350
563658	44	20	49,0	M18	12	235
554298	49	22	52,0	M20	12	300
554299	49	24	55,0	M20	12	390
554300	49	28	62,0	M20	12	505
564665	60	28	64,0	M24	12	550
564681	60	36	77,0	M24	12	985
572093	60	36	77,0	M30	12	1061

NEW!

Subject to technical alterations.

## No. 7600S

### Ball pressure screw

Tempered steel, burnished.



Order no.	Size	M1	L	SW	Weight [g]
556408	22	M12	43	6	30
553353	30	M16	62	8	80
554214	32	M16	55	8	70
554215	40	M20	65	10	128
553441	43	M20	80	10	165
554216	44 / 49	M24	93	12	275
564669	60	M24	105	12	320

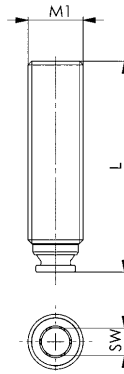

## No. 7600SE

### Ball pressure screw with hexagon head for power clamp

Tempered steel, burnished.



Order no.	Size	M1	L	SW	Weight [g]
571088	22	M12	50	10	37
571089	30	M16	82	13	115
571090	32	M16	66	13	88
571091	40	M20	79	16	163
571092	43	M20	79	16	202
571093	44/49	M24	112	21	353
571094	60	M24	125	21	399

### Advantage:

The hexagon head of the ball pressure screw is resistant to dirt during machining processes. Process reliable clamping with a specified torque.

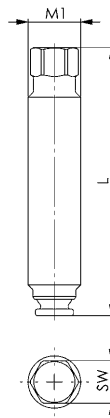

### Recommendations



No. 7600,  
page 7



No. 7630,  
page 12

Subject to technical alterations.

## No. 7600D

### Pressure pad

Complete with dowel pin.  
Stainless steel.



Order no.	Size	Form	A	A1	B	C	Weight [g]
556409	22	DG	14	4,5	19	12	11
556410	22	DR	14	4,5	19	12	10
553351	30 / 32	DG	19,5	6,0	25	18	28
553352	30 / 32	DR	19,5	6,0	25	18	27
553442	40 / 43	DG	24,0	6,5	30	20	47
553443	40 / 43	DR	24,0	6,5	30	20	48
554301	44 / 49	DG	28	7,0	36	25	75
554302	44 / 49	DR	28	7,0	36	25	78
564667	60	DG	29	8,0	43	28	115
564668	60	DR	29	8,0	43	28	110

DG = smooth contact surface, DR = wavy contact surface

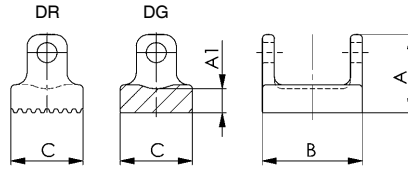

### Recommendations



ISO 2936C



No. 6339,  
page 119

CAD



## No. 7600DGK

### Thrust piece plastic (plain)



Order no.	Size	A	A1	B	C	Weight [g]
563695	22	12,5	3,0	20	11,4	2
563697	30 / 32	19,5	5,25	27	18,0	6
563698	40 / 43	24,0	5,75	30	24	9
563699	44 / 49	28,0	6,25	38	25	15

### Advantage:

Suitable for processing sensitive workpieces/surfaces (e.g. aluminium).

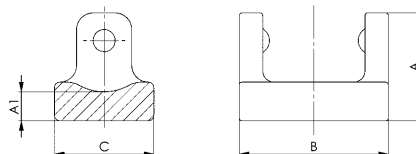

### Recommendations



No. 7600,  
page 7



No. 7600D,  
page 10

Subject to technical alterations.

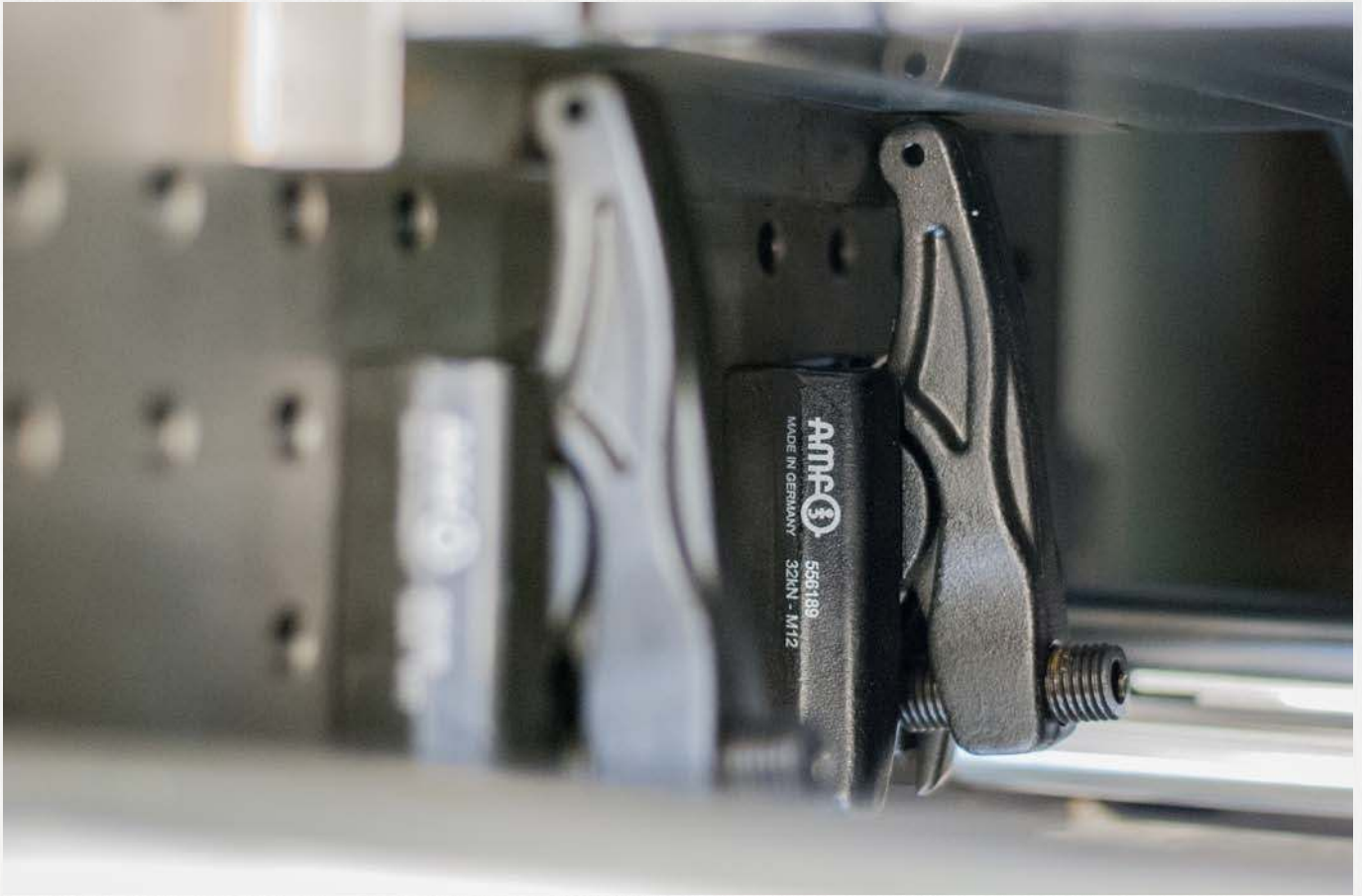

Subject to technical alterations.

## No. 7630

### Power clamp 3-step

Made of alloyed tempered steel, forged and black galvanized. Complete with 3-step support element, clamping unit and mounting kit 7630BFS. Thrust piece in smooth and ribbed variant, optionally available.



Order no.	Size	max. load static [kN]	M	H	E	L	Weight [g]
559877	22	22	M12	9 - 74	30 - 58	65	1120
559879	30	30	M12	13 - 129	37 - 106	130	4600
559881	43	43	M16	16 - 147	48 - 144	150	6844
559882	49	49	M20	16 - 169	68 - 172	170	10870

### Application:

1. Position carrier element on the tool table and secure with the specified tightening torque Md.
2. Move the clamp arm to the desired position.
3. Moving the adjusting screw clamps the workpiece.

### Advantage:

- Captive feature by means of threaded stud at all levels
- 3-fold continuously adjustable adjustment range
- High clamping forces of 22 kN - 49 kN
- Height and length continuously adjustable
- The very robust design enables quick and easy clamping
- Elements easy to install
- For use in T-slots 14 - 28 mm or grid plates M12, M16, M20
- 2 thrust piece variants

### Note:

- The max. load may differ, depending on the manner of clamping and condition of the threads (lubrication).
- To reduce the wear on the adjusting screw, we recommend the use of AMF screw compound no. 6339. It possesses a synergistic combination of highly-effective solid lubricants, is heat-resistant, and does not wash out.
- Use only the corresponding AMF mounting kit No. 7630BFS.
- If the clamping element without T-slot nut DIN 508 is used, the tensile strength of the support plate must be at least 900 N/mm<sup>2</sup>!
- **Not suitable for use on injection moulding and die-casting machines and presses.**

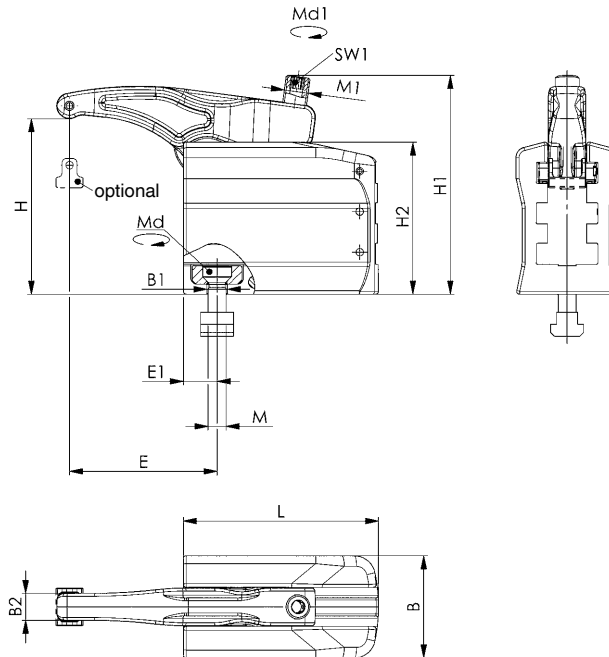

### Dimensions:

Order no.	Size	B	B1	B2	E1	H1	H2	M1	SW1	Md [Nm]	Md 1 [Nm]
559877	22	52	13,5	13,0	14,5	98	67	M12	6	40	55
559879	30	68	13,5	18,0	22,5	146	101	M16	8	70	100
559881	43	75	17,5	20,0	25,0	175	116	M20	10	150	200
559882	49	85	22,0	25,0	29,0	207	138	M24	12	200	220

Subject to technical alterations.



## No. 7630T

### Carrier element 3-step

Made of alloyed tempered steel, forged and black galvanized. Complete with pressure plate and mounting kit 7630BFS.



Order no.	Size	M	Slot	H	H2	L	Weight [g]
559925	22	M12	14	9 - 74	67	65	795
559926	30	M12	14	13 - 129	101	130	3440
559930	43	M16	18	16 - 147	116	150	5010
559931	49	M20	22	16 - 169	138	170	7710

### Application:

1. Position carrier element on the tool table and secure with the specified tightening torque Md.
2. Move the clamp arm to the desired position.
3. Moving the adjusting screw clamps the workpiece.

### Advantage:

- Captive feature by means of threaded stud at all levels
- 3-fold continuously adjustable adjustment range
- High clamping forces of 22 kN - 49 kN
- Height and length continuously adjustable
- The very robust design enables quick and easy clamping
- Elements easy to install
- For use in T-slots 14 - 28 mm or grid plates M12, M16, M20
- 2 thrust piece variants

### Note:

- The max. load may differ, depending on the manner of clamping and condition of the threads (lubrication).
- To reduce the wear on the adjusting screw, we recommend the use of AMF screw compound no. 6339. It possesses a synergistic combination of highly-effective solid lubricants, is heat-resistant, and does not wash out.
- Use only the corresponding AMF mounting kit No. 7630BFS.
- If the clamping element without T-slot nut DIN 508 is used, the tensile strength of the support plate must be at least 900 N/mm<sup>2</sup>!
- **Not suitable for use on injection moulding and die-casting machines and presses.**

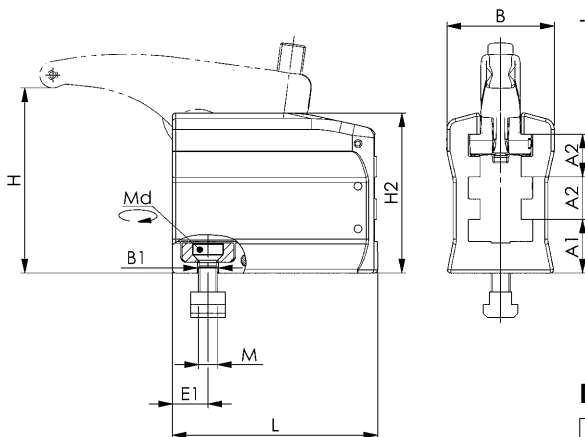

### Dimensions:

Order no.	Size	A1	A2	B	B1	E1	Md [Nm]
559925	22	25,0	16,5	52	13,5	14,5	40
559926	30	34,0	27,0	68	13,5	22,5	70
559930	43	43,0	29,0	75	17,5	25,0	150
559931	49	51,5	34,0	85	22,0	29,0	200

## No. 7630BFS

### Fastening kit for carrier element 3-step

Comprising fastening bolt of strength class 12.9, T-nut DIN 508 and pressure plate.



Order no.	Size	A	L	M	SW	Weight [g]
559909	22	14	35,5	12	6	95
559912	30	14	41,0	12	8	139
559914	43	18	52,0	16	10	258
559915	49	22	66	20	12	511

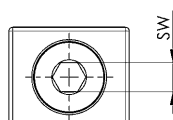
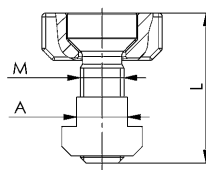

## No. 7640

### Compact clamp

Continuously adjustable clamping element made of tempered steel. Black, galvanised in tempered investment casting. Complete with fastening kit 7640BFS and captive, smooth compression piece.



Order no.	Size	max. load static [kN]	G	Slot	H	E	L	Weight [g]
567996	12	12	M12	14	0 - 100	38,5 - 59,5	141,5 - 163,0	2271
567997	16	16	M12	14	0 - 90	22,8 - 40,2	126,0 - 143,5	2166

### Application:

Mount compact clamp on the machine table with fastening kit 7640BFS, then position and fasten to the machine table with the specified torque. Clamp workpiece (observe torque).

### Advantage:

- Continuous clamping
- clamping forces 12kN / 16kN
- compact design
- height scale permits fast presetting of the clamping height
- thrust piece captive-mounted
- repels dirt and chips
- Curved clamping arm ensures reliable vertical clamping of the fastening bolt with defined torque
- The compact clamp can be connected to the spacer element 7640Z without screws through a new type of quick-action clip

### Note:

- Use only the corresponding AMF mounting kit 7640BFS.
- When using the clamping element without T-slot nut DIN508, the tensile strength of the support plate must be at least 900 N/mm<sup>2</sup>
- Do not clean with compressed air.

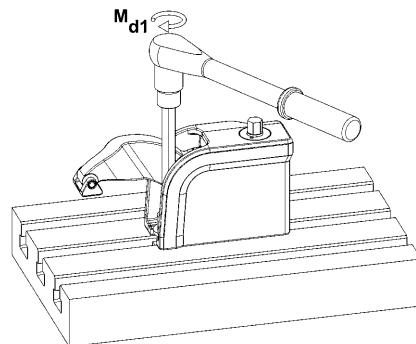
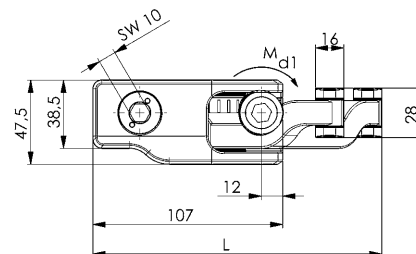
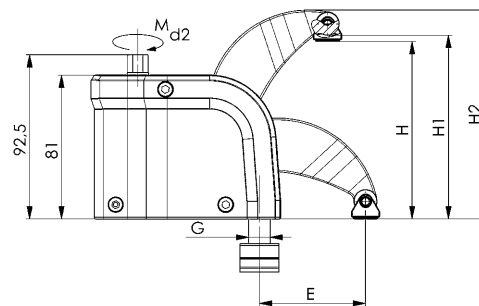

①

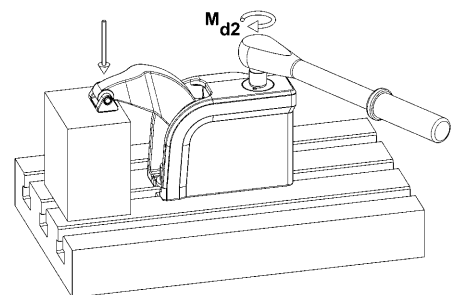

②

### Recommendations



No. 7640Z,  
page 15



No. 7640D,  
page 20



No. 7640BFS,  
page 20

### Dimensions:

Order no.	Size	Max. load, dynamic swelling [kN]	H1	H2	Md 1 [Nm]	Md 2 [Nm]
567996	12	9	3,5 - 103,5	56,5 - 118	40	100
567997	16	12	3,5 - 93,5	52,0 - 107	40	100

Subject to technical alterations.

## No. 7640Z

### Spacer element with quick-action clip

Made of alloyed tempered steel. Black, galvanised in tempered investment casting. Complete with mounting kit 7640BFS.



Order no.	Size	Height [mm]	Md 1 [Nm]	Weight [g]
567998	12/16	80	80	1406

### Application:

Mount the spacer element on the machine table with the fastening kit 7640BFS. Then connect the compact clamp with the quick-action clip. Fasten the clamping unit to the machine table with the specified torque. Now the workpiece can be clamped.

### Advantage:

- new type of quick-action clip permits screw-free connection of the spacer elements to each other and to the compact clamp.
- Continuous transition between the clamping heights.
- Reliable clamping of the fastening bolt with defined torque guaranteed.

### Note:

- Use only the corresponding AMF mounting kit 7640BFS.
- When using the clamping element without T-slot nut DIN508, the tensile strength of the support plate must be at least 900 N/mm<sup>2</sup>.
- Recommendation: build a maximum of 2 spacer elements onto each other.

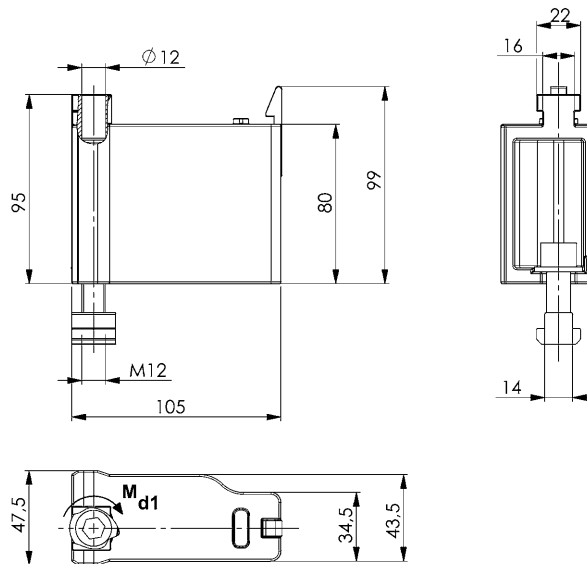

### Recommendations



No. 7640,  
page 14



No. 7640BFS,  
page 20

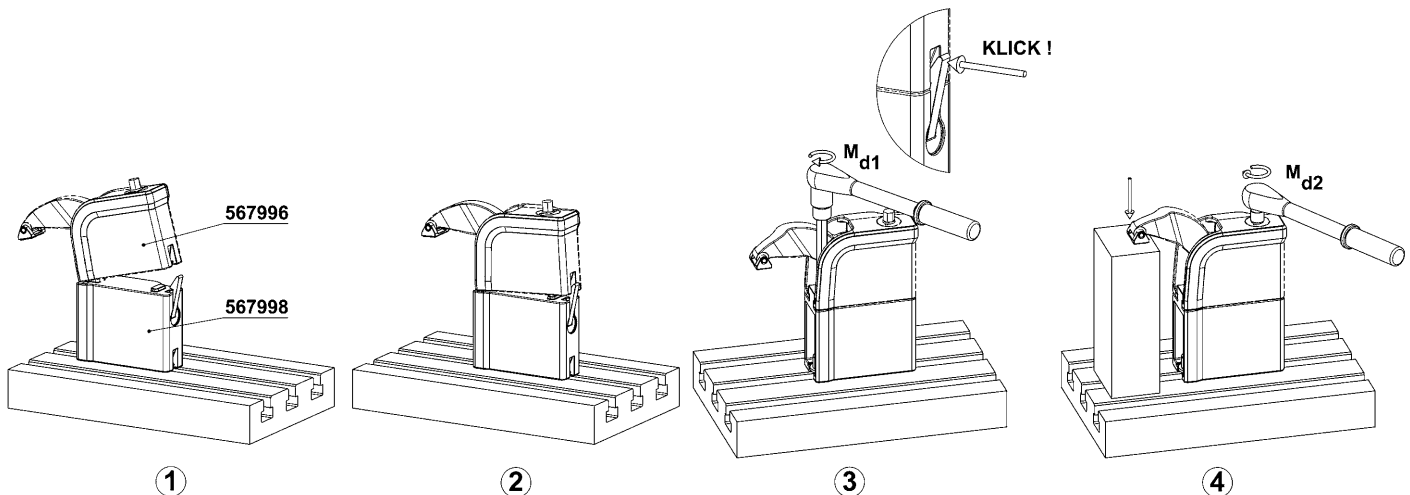

No. 7650

## Swing clamp, mechanical

Burnished tempered steel, complete with fastening bolts of strength 10.9 and washers.

**NEW!**



Order no.	Size	max. load static [kN]	G [mm]	H [mm]	L [mm]	E [mm]	Weight [g]
572511	15	15	M6	47 - 52	57,5	6,0	426,5
572512	18	18	M8	57 - 62,5	73,0	8,8	797,3
572513	20	20	M10	67 - 72	86,0	10,0	1329,9
572514	25	25	M12	87 - 92	102	16,5	2455

### Application:

The swing clamp can be positioned vertically or horizontally and fastened onto the device plate with two fastening bolts of strength 10.9. The clamp arm is clamped with the actuation bolt of strength 12.9.

### Advantage:

- Compact design
- Swivels right and left in a clamp
- Swivel angle 180°
- Safety-relevant stroke limitation of the clamp arm through integrated securing
- High tensioning force ensures secure fixing even under high loads

### Note:

- The maximum load may differ depending on the condition of the attaching threads of the screws (lubrication).
- When using the clamping element on device plates, the tensile strength of the device plate must be at least 900 N/mm<sup>2</sup>.
- To reduce wear to the fastening and actuation bolt, we recommend using AMF screw compound No. 6339. It possesses a synergistic combination of highly-effective solid lubricants and is heat-resistant.

### On request:

Other sizes.

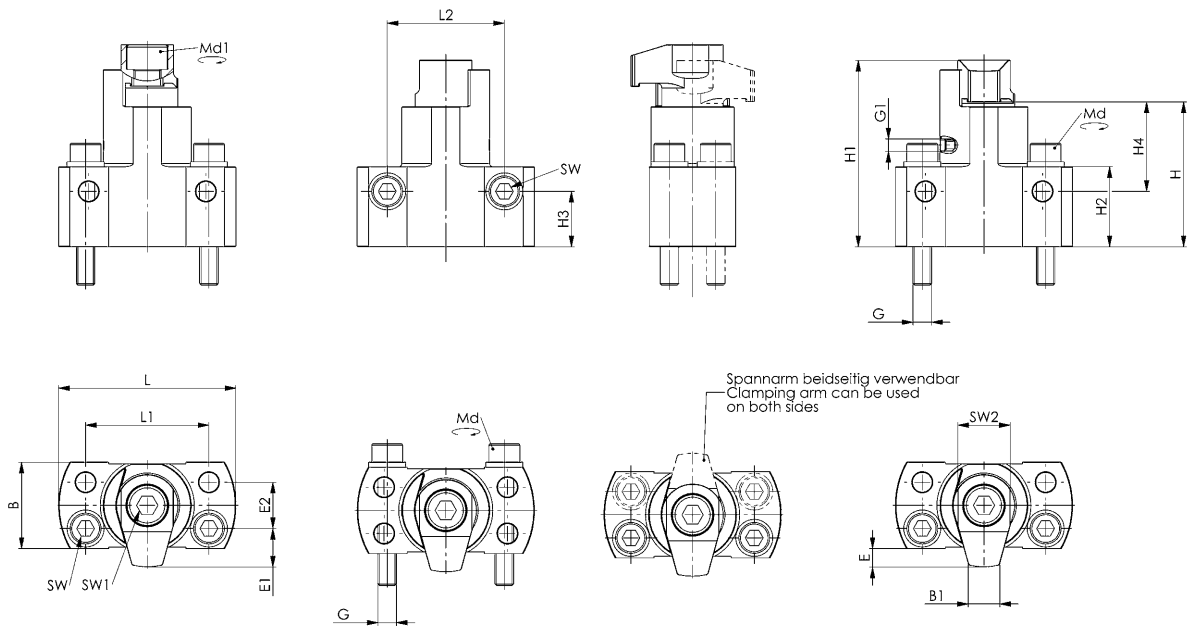

### Dimensions:

Order no.	Size	B [mm]	B1 [mm]	E1 [mm]	E2 [mm]	G1 [mm]	H1 [mm]	H2 [mm]	H3 [mm]	H4 [mm]	L1 [mm]	L2 [mm]	Md [Nm]	Md 1 [Nm]	SW [mm]	SW 1 [mm]
572511	15	28	10	12,5	15	M4	60,7 - 66,8	26,0	18	29 - 34	40	38	14	30	5	6
572512	18	34	12	17,5	17	M5	72,5 - 78,0	31,5	21	36 - 41,5	53	48	36	50	6	8
572513	20	40	15	20,5	19	M5	85,5 - 90,5	37,5	24	43 - 48	62	55	67	60	8	10
572514	25	48	18	29,5	22	M6	112 - 117	48,0	32	55 - 60	74	65	120	110	10	14

Subject to technical alterations.

## Application examples:

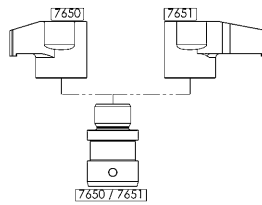
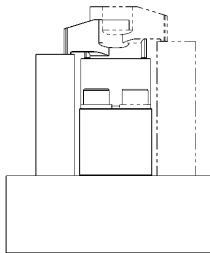
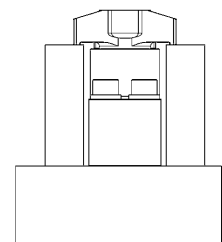
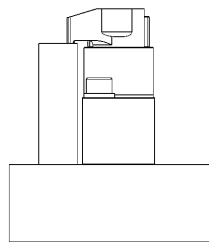
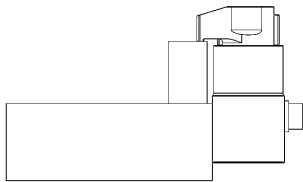
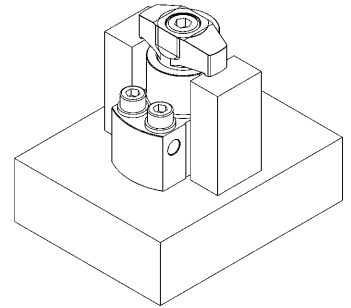
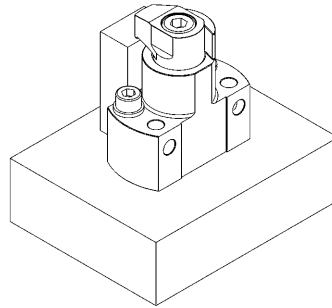
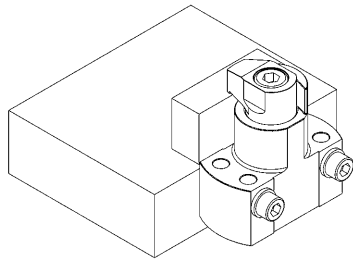

No. 7651

## Swing clamp, mechanical, modular

Body: painted tempered steel.

Base element: burnished tempered steel.

**NEW!**



Order no.	Size	max. load static [kN]	G [mm]	H [mm]	L [mm]	E [mm]	Weight [g]
572515	10	10	M12	63,5 - 68,5	50	5	696
572516	13	13	M12	72 - 77	50	7	836
572517	14	14	M12	81,5 - 86,5	50	10	1083
572518	15	15	M16	100 - 105	50	20	1716

### Application:

The swing clamp can be positioned vertically or horizontally and fastened onto device plates and T-slot tables. The clamp arm is clamped with the actuation bolt of strength 12.9.

### Advantage:

- Compact, modular design
- Use of the AMF spacer elements 6400Z, with a maximum installation height of 50 mm
- Use of the AMF base elements 6400FB M12 and M16
- Swivel angle 360°
- Safety-relevant stroke limitation of the clamp arm through integrated securing
- High clamping force ensures secure fixing even under high loads

### Note:

- The maximum load may differ depending on the condition of the attaching threads of the screws (lubrication).
- When using the clamping element on device plates, the tensile strength of the device plate must be at least 900 N/mm<sup>2</sup>.
- To reduce wear to the fastening and actuation bolt, we recommend using AMF screw compound No. 6339. It possesses a synergistic combination of highly-effective solid lubricants and is heat-resistant. The swing clamp can be positioned vertically or horizontally and fastened onto the device plate with two fastening bolts of strength 10.9.

### On request:

Other sizes.

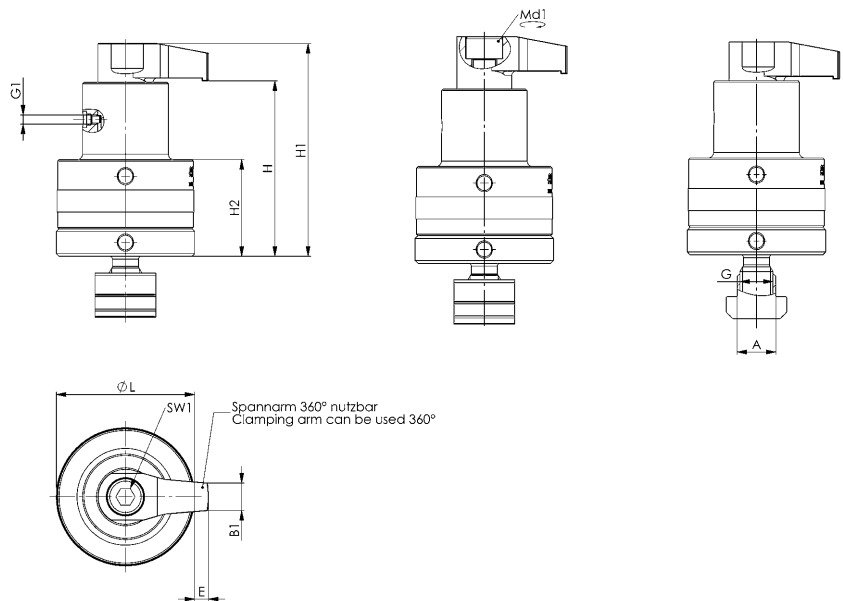

### Dimensions:

Order no.	Size	A [mm]	B1 [mm]	G1 [mm]	H1 [mm]	H2 [mm]	Md 1 [Nm]	SW 1 [mm]
572515	10	14	9	M4	77 - 82	35	25	6
572516	13	14	11	M5	87,5 - 92,5	35	30	8
572517	14	14	13	M5	100 - 105	35	40	10
572518	15	18	17	M6	125 - 130	35	50	14

Subject to technical alterations.

## Installation recommendations and dimensions when using AMF intermediate elements 6400Z-25 and 6400Z-50:

Size	6400Z	Number	H [mm]	H1 [mm]	Md 1 [Nm]	FSp [kN]
10	6400Z-25	1	88,5 - 93,5	102 - 107	20	9
		2	113,5 - 118,5	127 - 132		
	6400Z-50	1	113,5 - 118,5	127 - 132		
13	6400Z-25	1	97 - 102	112,5 - 117,5	25	11
		2	122 - 124	137,5 - 142,5		
	6400Z-50	1	122 - 127	137,5 - 142,5		
14	6400Z-25	1	106,5 - 111,5	125 - 130	27	10
		2	131,5 - 136,5	150 - 155		
	6400Z-50	1	131,5 - 135,6	150 - 155		
15	6400Z-25	1	125 - 130	150 - 155	35	9
		2	150 - 155	175 - 180		
	6400Z-50	1	150 - 155	175 - 180		

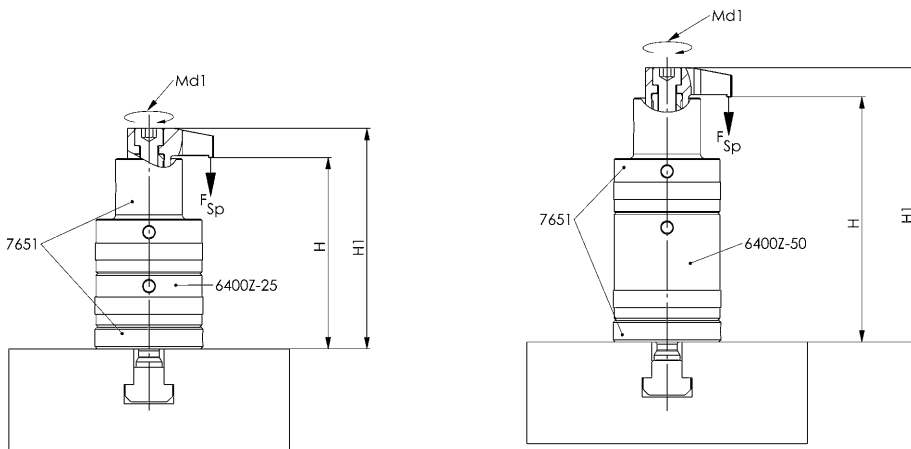

## Application examples:

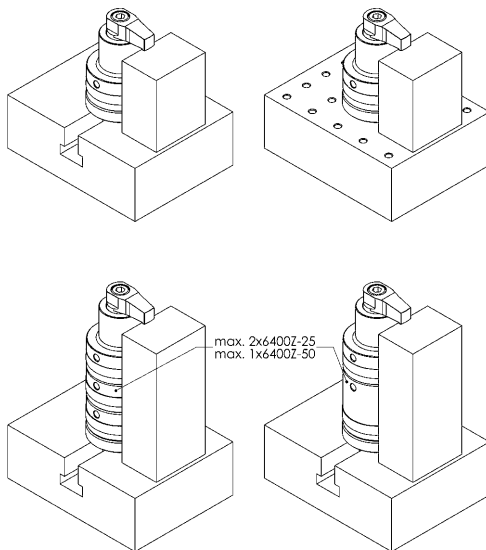

## No. 7640BFS

### Mounting kit

Consisting of cylinder screw ISO4762, T-nut 508, disc ISO7090.



Order no.	Size	A	dia. D	L	M	SW	Weight [g]
568000	12/16	14	24	30	M12	10	90

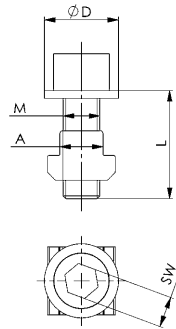

## No. 7640D

### Thrust piece set

Top parts with magnetic insert.

Design: fluted, crosswise prism, lengthwise prism and plastic.

Order no.	Size	Weight [g]
567999	12/16	60

#### Advantage:

Depending on the workpiece surface, top parts can be attached easily and quickly to the existing thrust piece using the installed magnet.

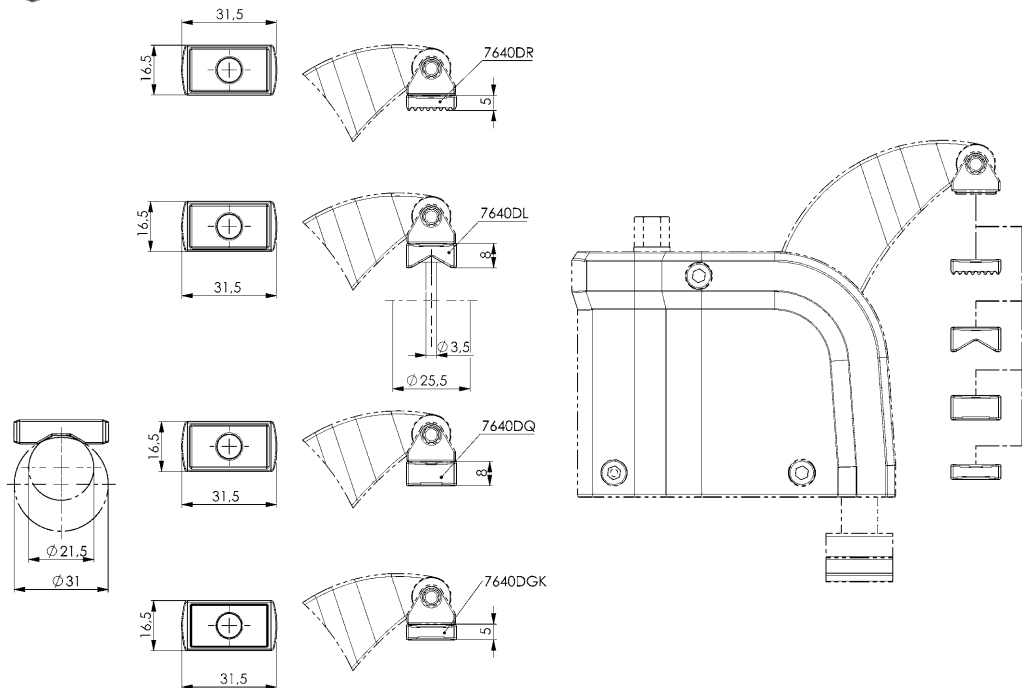

## CLAMPING WITH SINGLE CLAMPS OR WITH COMPACT CLAMPING UNITS

- > **Material:** Tempering steel to DIN regulations.
- > **Machining:** Plane-parallel base- and clamping faces ensure safe force transmission.
- > **Tempering:** According to DIN regulations.
- > **Finishing:** All clamps are abrasionproof quality varnished, or of equal quality finish.

Where high clamping forces or flexible adaption to shapes and sizes of workpieces are demanded, we offer our single clamps or clamping combinations by using our adjustable clamps.

All AMF-clamps shown in this catalogue be combined with different support blocks and are therefore adaptable to different shaped and sized workpieces.

The Advantages of these adjustable clamps are their universal application abilities for single parts up to medium series production with changing clamping dimensions. They allow simple and fast horizontal and vertical application, are interchangeable and price worthy. Their compact design ensures high clamping forces even at large clamping dimensions.



## No. 6312V

### „Crocodile“ clamp

Continuously adjustable, tempered, galvanized, with undetachable compression piece and back support.



Order no.	B1	for clamping screw	Slot	Clamping force max.* [kN]	H1	L	Weight [g]
79756	13	M10, M12	10, 12, 14	30	0-55	115	661
79798	17	M12, M16	12, 14, 16, 18	40	0-70	150	1494
79855	21	M16, M20	16, 18, 20, 22	60	0-80	187	2252
79913	25	M20, M24	20, 22, 24, 28	75	0-100	235	3635
376475	25	M20, M24	20, 22, 24, 28	75	0-100	285	4335

\* Specified clamping forces in optimal clamping position (smallest distance from the clamping screw to the clamping point). Clamping forces can vary depending clamping, strength class of the clamping screw and condition of the thread (lubrication).

### Application:

The crocodile clamping claw is used for all clamping tasks using T-slots and threaded holes. Thrust piece and counter-bearing are connected permanently to the clamping jaw, and thus the crocodile is quickly ready to use. The clamping jaw features two ridges and can be turned around easily depending on the application. In this way, it is possible to cover all fields of application involving cutting and non-cutting processes (e.g. injection moulding and pressure forming).

### Advantage:

- Variable and fast adjustment option at a distance from the workpiece
- Use in all areas involving cutting and non-cutting processes
- Especially well-suited for use on injection moulding machines and presses
- No additional supports needed to achieve the required clamping height
- Thrust piece and counter-bearing are connected permanently to the clamping jaw
- The crocodile can be extended easily for every clamping height.

### Note:

For clamping, either clamping studs DIN 787, studs DIN 6379 and cylinder screws ISO 4762 can be used. Greater clamping heights can be achieved using the support extension No. 6312S. A washer disc DIN 6340 must always be used between the hexagonal nut and compression piece!

### Dimensions:

Order no.	A	A1	A2	B2	B3	E1	E2	H2	K
79756	27	17	12	44	30	25	30	18	11
79798	36	21	17	55	41	35	36	20	12
79855	42	27	20	62	30	44	44	30	14
79913	51	34	24	70	30	60	47	31	17
376475	56	35	24	73	30	62	51	35	17

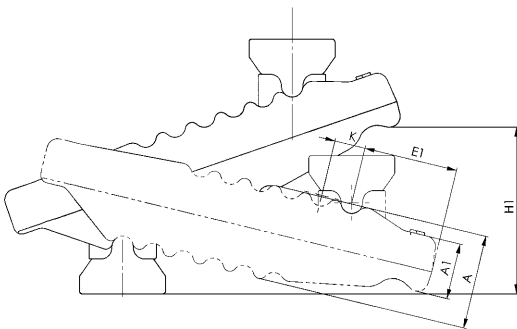
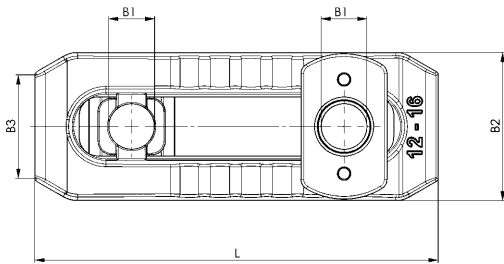
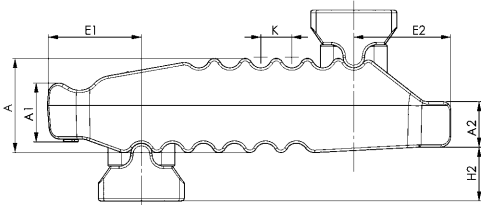

### Recommendations



No. 6312S,  
page 26



No. 787,  
page 96



No. 6379I,  
page 102

CAD



Subject to technical alterations.

## No. 6312VT

### „Crocodile“ clamp, complete with DIN 787

with clamping bolt DIN 787, washer DIN 6340 and nut DIN 6330B. Infinitely adjustable, tempered, galvanised with captive compression piece and counter bearing.

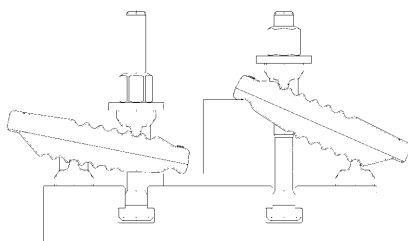
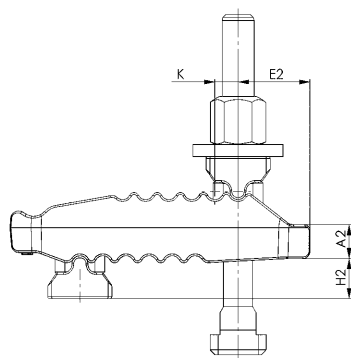
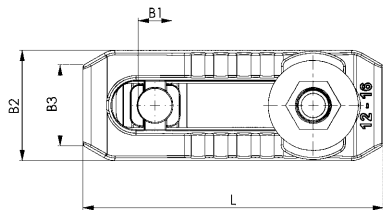
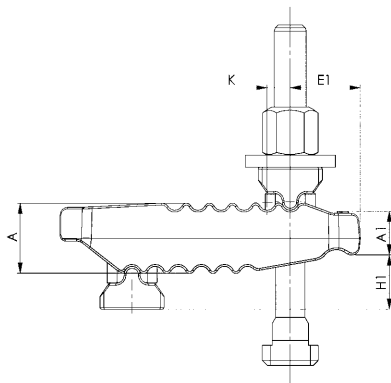

Order no.	B1	Slot	Clamping bolt DIN 787	Clamping force max.* [kN]	H1	Weight [g]
79780	13	10	M10x10x100	25	0-40	613
79806	13	12	M12x12x125	30	0-55	686
79822	13	14	M12x14x125	30	0-55	705
79848	17	12	M12x12x160	35	0-70	1591
79863	17	14	M12x14x160	35	0-70	1610
79889	17	16	M16x16x160	40	0-70	1798
79905	17	18	M16x18x160	40	0-70	1818
79921	21	16	M16x16x200	55	0-80	2715
79210	21	18	M16x18x200	55	0-80	3018
79228	21	20	M20x20x200	60	0-80	3018
374926	21	22	M20x22x200	60	0-80	3060
374942	25	20	M20x20x250	70	0-100	4368
374967	25	22	M20x22x250	70	0-100	4410
374983	25	24	M24x24x250	75	0-100	4895
375006	25	28	M24x28x250	75	0-100	4966

\* Specified clamping forces in optimal clamping position (smallest distance from the clamping screw to the clamping point). Clamping forces can vary depending clamping, strength class of the clamping screw and condition of the thread (lubrication).

### Application:

The crocodile clamping claw is used for all clamping tasks using T-slots and threaded holes. Thrust piece and counter-bearing are connected permanently to the clamping jaw, and thus the crocodile is quickly ready to use. The clamping jaw features two ridges and can be turned around easily depending on the application. In this way, it is possible to cover all fields of application involving cutting and non-cutting processes (e.g. injection moulding and pressure forming).

### Advantage:

- Variable and fast adjustment option at a distance from the workpiece
- Use in all areas involving cutting and non-cutting processes
- Especially well-suited for use on injection moulding machines and presses
- No additional supports needed to achieve the required clamping height
- Thrust piece and counter-bearing are connected permanently to the clamping jaw
- The crocodile can be extended easily for every clamping height.

### Note:

For missing dimensions, see No. 6312V.

### Dimensions:

Order no.	A	A1	A2	B2 x L	B3	E1	E2	H2	K
79780	27	17	12	44x115	30	25	30	18	11
79806	27	17	12	44x115	30	25	30	18	11
79822	27	17	12	44x115	30	25	30	18	11
79848	36	21	17	55x150	41	35	36	20	12
79863	36	21	17	55x150	41	35	36	20	12
79889	36	21	17	55x150	41	35	36	20	12
79905	36	21	17	55x150	41	35	36	20	12
79921	42	27	20	62x187	30	44	44	30	14
79210	42	27	20	62x187	30	44	44	30	14
79228	42	27	20	62x187	30	44	44	30	14
374926	42	27	20	62x187	30	44	44	30	14
374942	51	34	24	70x235	30	60	47	31	17
374967	51	34	24	70x235	30	60	47	31	17
374983	51	34	24	70x235	30	60	47	31	17
375006	51	34	24	70x235	30	60	47	31	17

### Recommendations



No. 6312S,  
page 26



No. 787,  
page 96



No. 6379I,  
page 102



## No. 6312VS

### „Crocodile“ clamp, complete with DIN 6379

with stud bolt DIN 6379, washer DIN 6340 and nut DIN 6330B. Infinitely adjustable, tempered, galvanised with captive compression piece and counter bearing.

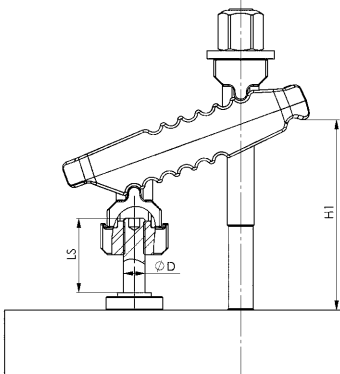
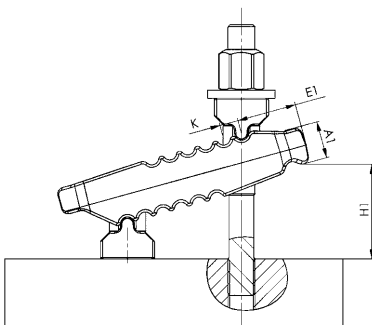
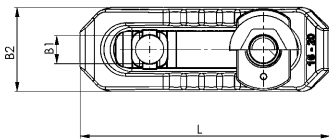
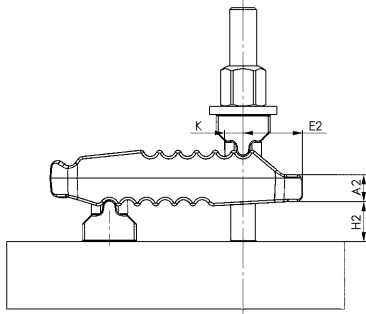

Order no.	B1	Clamping bolt DIN 6379	Support extension 6312V	Clamping force max.* [kN]	H1	Weight [g]
375766	13	M12x100	-	30	0-30	639
375782	13	M12x125	-	30	0-55	659
375808	17	M12x125	-	40	0-50	1535
375824	17	M12x160	-	40	0-70	1558
375840	17	M16x125	-	40	0-40	1660
375865	17	M16x160	-	40	0-70	1718
375881	21	M20x160	-	60	0-40	2754
375907	21	M20x200	-	60	0-80	2834
375923	25	M20x200	-	75	0-70	4072
375949	25	M20x250	-	75	0-100	4172
375964	25	M24x200	-	75	0-50	4374
375980	25	M24x250	-	75	0-100	4524
375816	21	M20x250	M16x55	60	30-141	3428
375832	21	M20x315	M16x90	60	40-190	3704
375857	25	M20x315	M20x69	75	50-175	5438
375873	25	M20x400	M20x109	75	50-220	5873
375899	25	M24x315	M20x69	75	45-180	5850
375915	25	M24x400	M20x109	75	45-215	6350

\* Specified clamping forces in optimal clamping position (smallest distance from the clamping screw to the clamping point). Clamping forces can vary depending clamping, strength class of the clamping screw and condition of the thread (lubrication).

### Application:

The crocodile clamping claw is used for all clamping tasks using T-slots and threaded holes. Thrust piece and counter-bearing are connected permanently to the clamping jaw, and thus the crocodile is quickly ready to use. The clamping jaw features two ridges and can be turned around easily depending on the application. In this way, it is possible to cover all fields of application involving cutting and non-cutting processes (e.g. injection moulding and pressure forming).

### Advantage:

- Variable and fast adjustment option at a distance from the workpiece
- Use in all areas involving cutting and non-cutting processes
- Especially well-suited for use on injection moulding machines and presses
- No additional supports needed to achieve the required clamping height
- Thrust piece and counter-bearing are connected permanently to the clamping jaw
- The crocodile can be extended easily for every clamping height.

### Note:

For missing dimensions, see no. 6312V.

### Dimensions:

Order no.	A	A1	A2	B2 x L	B3	E1	E2	H2	K
375766	27	17	12	44x115	30	25	30	18	11
375782	27	17	12	44x115	30	25	30	18	11
375808	36	21	17	55x150	41	35	36	20	12
375824	36	21	17	55x150	41	35	36	20	12
375840	36	21	17	55x150	41	35	36	20	12
375865	36	21	17	55x150	41	35	36	20	12
375881	42	27	20	62x187	30	44	44	30	14
375907	42	27	20	62x187	30	44	44	30	14
375923	51	34	24	70x235	30	60	47	31	17
375949	51	34	24	70x235	30	60	47	31	17
375964	51	34	24	70x235	30	60	47	31	17
375980	51	34	24	70x235	30	60	47	31	17
375816	42	27	20	62x187	30	44	44	63-91	63
375832	42	27	20	62x187	30	44	44	63-123	63
375857	51	34	24	70x235	30	60	47	72-108	72
375873	51	34	24	70x235	30	60	47	72-147	72
375899	51	34	24	70x235	30	60	47	72-108	72
375915	51	34	24	70x235	30	60	47	72-147	72

### Recommendations



No. 6312S, page 26



No. 6379I, page 102



Subject to technical alterations.

## No. 6312VI

### „Crocodile“ clamp, complete with no. 6379I

with stud no. 6379I, hexagon screwdriver ISO 2936C, washer DIN 6340 and nut DIN 6330B. Continuously adjustable, tempered, galvanised with captive thrust piece and counter bearing.



Order no.	B1	Clamping bolt No. 6379I	Clamping force max.* [kN]	H1	SW [mm]	Weight [g]
375956	13	M12x100	30	0-30	4	639
375972	13	M12x125	30	0-55	4	659
375998	17	M12x125	40	0-50	4	1535
376004	17	M12x160	40	0-70	4	1558
376012	17	M16x125	40	0-40	4	1660
376020	17	M16x160	40	0-70	4	1718
376038	21	M16x160	60	0-40	4	2587
376046	21	M16x200	60	0-80	4	2625
376053	21	M20x160	60	0-40	5	2745
376061	21	M20x200	60	0-80	5	2834
376079	25	M20x200	75	0-70	5	4072
376087	25	M20x250	75	0-100	5	4172
376103	25	M24x200	75	0-50	5	4374
376095	25	M24x250	75	0-100	5	4524

\* Specified clamping forces in optimal clamping position (smallest distance from the clamping screw to the clamping point). Clamping forces can vary depending clamping, strength class of the clamping screw and condition of the thread (lubrication).

#### Advantage:

For better handling when setting up the clamping element, the threaded pin can be mounted and removed using an Allen key.

#### Note:

Use the Allen key only to set up the clamping element, not for clamping!  
For missing dimension, see no. 6312V.

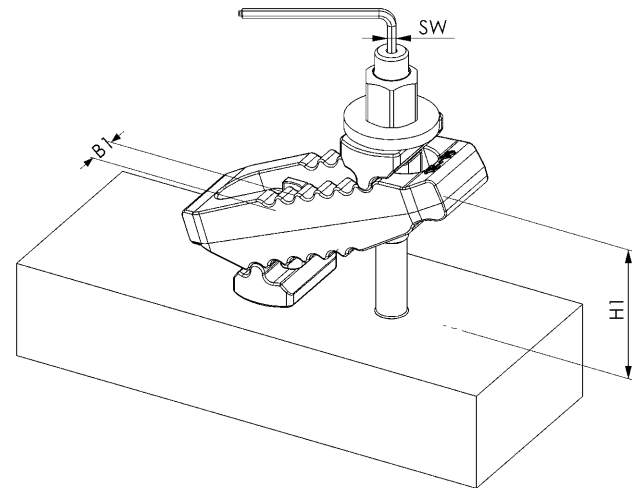

#### Recommendations



No. 6312S,  
page 26

Subject to technical alterations.



## No. 6312S

### Support extension

Steel, galvanised and tempered, support screw, hardened, strength class 8.8. Comprising body, support screw and fastening bolts.



Order no.	B1	D x LS	A	B	C	D1	E	G	H	K	Weight [g]
79772	13	M10x39	10	30	30	30	44	M5	18 - 40	8	197
79814	17	M12x49	16	35	42	36	54	M5	25 - 53	10	433
79830	17	M12x94	16	35	42	36	54	M5	26 - 96	10	473
79871	21	M16x55	20	40	50	42	60	M5	33 - 61	13	608
79897	21	M16x90	20	40	50	42	60	M5	33 - 93	13	640
79749	25	M20x69	25	50	46	50	70	M6	41 - 77	16	910
79764	25	M20x109	25	50	46	50	70	M6	41 - 116	16	1000

### Application:

To increase the clamping height, the support extension is screwed to the counter-bearing of the crocodile.

### Advantage:

Continuous adjustment of clamping heights.

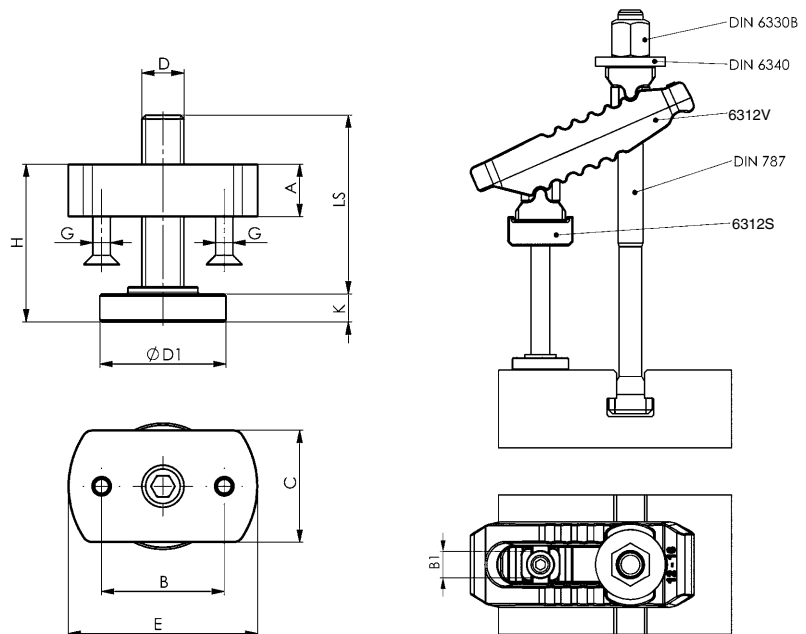

CAD



The right size for your application is always available, for example, order no. 6312V, without clamping bolt

**Requirements:** Table slot 18 / required clamping height: 125 mm / required clamping force: 35 kN

#### 1) Select clamp no. 6312V

Groove 18 ▶ clamping force 40 kN ▶ B1 = 17 ▶ crocodile order no. 79798

#### 2) For a clamping height of 125 mm, support extension no. 6312S is used

B1 = 17 ▶ groove 18 ▶ clamping height 125 mm (clamping range 26-166 mm) ▶ DxLS = M12x94  
▶ Support extension order no. 79830

#### 3) Size of the T-slot bolts DIN787, complete with washer and hexagon nut

M16x18x250 ▶ order no. 81042

## Installation recommendations and dimensions when using the clamping bolt ISO 4762 (without support extension 6312S)

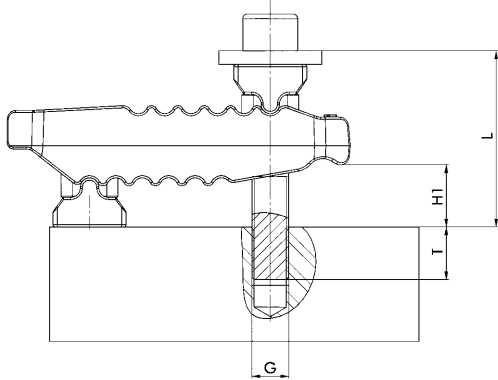

B1	Dimensions ISO 4762 G x L	Clamping height H1	Thread depth T
13	M10x80	4-25	15-31
13	M10x90	17-40	15-31
13	M10x100	31-55	15-31
13	M12x80	0-20	18-33
13	M12x90	10-34	18-36
13	M12x100	22-50	18-36
17	M12x90	0-22	18-34
17	M12x110	24-50	18-36
17	M12x120	38-66	18-36
17	M16x100	0-26	24-43
17	M16x110	12-40	24-44
17	M16x120	26-55	24-44
21	M16x120	2-29	24-44
21	M16x130	15-43	24-44
21	M16x150	43-72	24-44
21	M20x140	18-48	30-52
21	M20x150	31-63	30-52
21	M20x160	45-78	30-52
25	M20x160	23-54	30-52
25	M20x180	51-83	30-52
25	M20x195	72-100	34-52
25	M24x140	0-15	36-48
25	M24x160	10-42	36-60
25	M24x180	37-71	36-60

## Installation recommendations and dimensions when using the clamping bolt DIN 787 (with support extension 6312S)

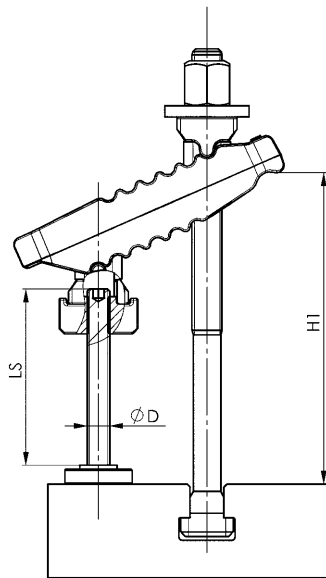

B1	D x LS	Dimensions DIN 787	Clamping range H1
13	M10x39	M10x10x100	18-31
13	M10x39	M12x12x160	18-95
13	M10x39	M12x14x160	18-95
17	M12x49	M12x12x200	26-123
17	M12x49	M12x14x200	26-123
17	M12x49	M16x16x200	26-123
17	M12x49	M16x18x200	26-123
17	M12x94	M12x12x200	26-120
17	M12x94	M12x14x200	26-120
17	M12x94	M16x16x250	26-166
17	M12x94	M16x18x250	26-166
21	M16x55	M16x16x250	33-141
21	M16x55	M16x18x250	33-141
21	M16x55	M20x20x250	33-141
21	M16x55	M20x22x250	33-141
21	M16x90	M16x16x250	33-150
21	M16x90	M16x18x250	33-150
21	M16x90	M20x20x315	33-173
21	M16x90	M20x22x315	33-173
25	M20x69	M20x20x315	41-177
25	M20x69	M20x22x315	41-177
25	M20x69	M24x24x315	41-177
25	M20x69	M24x28x315	41-177
25	M20x109	M20x20x315	41-197
25	M20x109	M20x22x315	41-193
25	M20x109	M24x24x315	41-180
25	M20x109	M24x28x315	41-180

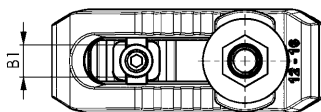

## No. 6310

### Clamp with plastic cap

and U-piece undetachable, (without clamping stud),  
burnished tempered steel.



Order no.	Size	for clamping screw	H1 *	B1	B2	L	A	A1	E1	Weight [g]
376863	10	M10	0-15	11	44	80	30,5	32,0	30	257
376889	14	M12 M14	0-33	14	57	125	47,0	49,5	37	708
376905	18	M16 M18	0-45	18	67	160	58,5	62,0	49	1235
376921	22	M20 M22	0-65	22	72	200	71,5	75,0	58	1880
376947	26	M22 M24	0-85	26	82	250	89,5	94,0	74	2799

\*depending on depth of slot to DIN 650 and position of fixture nut.

#### Application:

The clamp is used for all clamping tasks in which clamping is effected via T-grooves, grooves and threaded bores.

#### Advantage:

Weight-saving thanks to lightweight design. Variable and fast adjustment option at a distance from the workpiece. No additional clamping supports are needed to reach the required clamping height. The U-piece is undetachable from the clamp.

#### Note:

For clamping, either clamping screws DIN 787, stud bolts DIN 6379 and cheese head screws ISO 4762 can be used.

A washer DIN 6340 must always be used between the hexagonal nut and U-piece!

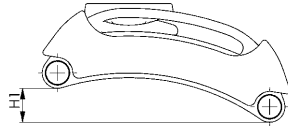
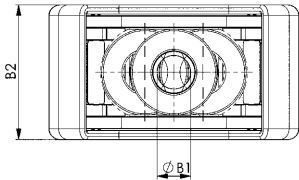
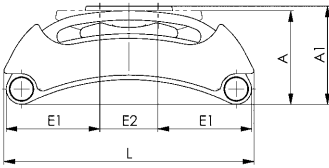

#### Recommendations



DIN 6340,  
page 113



DIN 787,  
page 94



DIN 6330B,  
page 107

## No. 6310

### Clamp with plastic cap, complete

with DIN 787, DIN 6340, DIN 6330B and undetachable U-piece,  
burnished tempered steel.



Order no.	Slot	with clamping stud	H1 *	B1	B2	L	A	A1	E1	E2	Weight [g]
376555	10	M10x10x80	0-15	11	44	80	30,5	32,0	30	19	349
376871	12	M12x12x100	0-33	14	57	125	47,0	49,5	37	51	886
376897	14	M12x14x125	0-33	14	57	125	47,0	49,5	37	51	905
376913	16	M16x16x160	0-45	18	67	160	58,5	62,0	49	63	1648
376939	18	M16x18x160	0-45	18	67	160	58,5	62,0	49	63	1668

\*depending on depth of slot to DIN 650 and position of fixture nut.

#### Application:

The clamp is used for all clamping tasks in which clamping is effected via T-grooves, grooves and threaded bores.

#### Advantage:

Weight-saving thanks to lightweight design. Variable and fast adjustment option at a distance from the workpiece. No additional clamping supports are needed to reach the required clamping height. The U-piece is undetachable from the clamp.

#### Note:

A washer DIN 6340 must always be used between the hexagonal nut and U-piece!

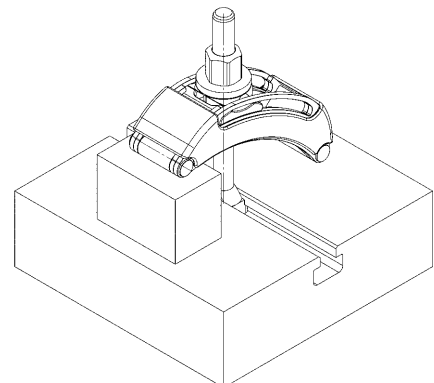
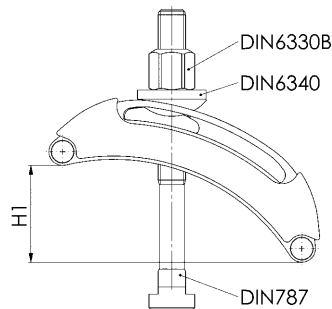
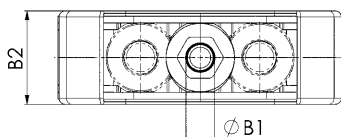
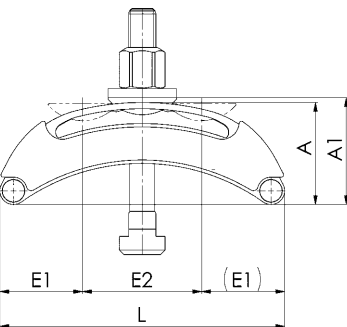

Subject to technical alterations.

## No. 6311

### Clamp, „light design“

Tempered steel, burnished.



CAD

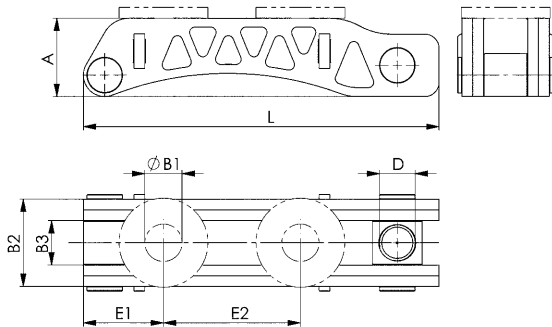

Order no.	Size	for clamping screw	B1	B2	B3	D	L	A	E1	E2	Weight [g]
376962	22	M20 M22	22	49	25	M20	200	44	45	77	1289
377002	26	M24	26	54	30	M24	250	44	46	116	1630
377044	33	M30	33	72	40	M30	315	71	59	152	4522
377069	43	M36 M42	43	102	54	M30	400	80	74	209	9709

\*depending on depth of slot to DIN 650 and position of fixture nut.

#### Application:

The clamp is used for all clamping tasks in which clamping is effected via T-grooves, grooves and threaded bores.

#### Advantage:

Through the weight-saving design, the clamping iron is up to 50% lighter, but still offers 100% clamping force and can thus also be used even for rotating clamping tasks. Variable and fast adjustment option at a distance from the workpiece.

#### Note:

For clamping, either clamping screws DIN 787, stud bolts DIN 6379 and cheese head screws ISO 4762 can be used.

**Up to 50 % lighter –  
100 % clamping force**

## No. 6311

### Clamp „light design“, with adjustable support screw, complete

with DIN 787, DIN 6340, DIN 6330B.

Tempered steel, burnished.



CAD

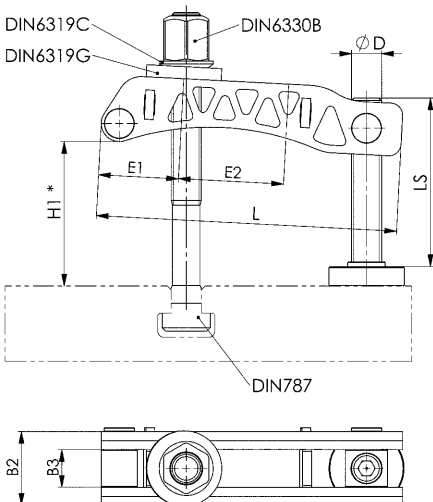

Order no.	Slot	with clamping stud	H1 *	D x LS	B1	B2	B3	L	A	E1	E2	Weight [g]
376731	20	M20x20x160	8-58	M20x69	22	49	25	200	44	45	77	2434
376756	20	M20x20x200	8-98	M20x109	22	49	25	200	44	45	77	2531
376772	24	M24x28x200	10-81	M24x87	26	54	30	250	44	46	116	3779
376798	24	M24x28x250	10-130	M24x137	26	54	30	250	44	59	116	3884
376814	36	M30x36x315	7-214	M30x180	33	72	40	315	71	59	152	9044
376830	48	M36x42x400	7-153	M30x180	43	102	54	400	80	74	209	17560

\*depending on depth of slot to DIN 650 and position of fixture nut.

#### Application:

The clamp is used for all clamping tasks in which clamping is effected via T-grooves, grooves and threaded bores.

#### Advantage:

Through the weight-saving design, the clamping iron is up to 50% lighter, but still offers 100% clamping force and can thus also be used even for rotating clamping tasks. Variable and fast adjustment option at a distance from the workpiece.

#### Note:

For clamping, either clamping screws DIN 787, stud bolts DIN 6379 and cheese head screws ISO 4762 can be used.

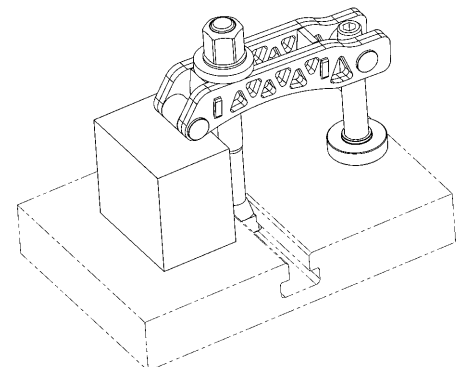
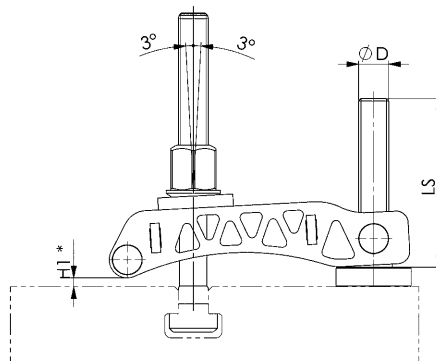

Subject to technical alterations.

## DIN 6314

### Clamp, flat

Tempering steel, varnished.

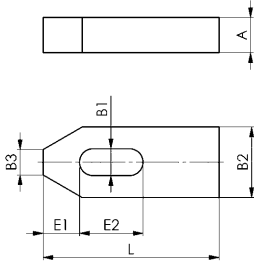

Order no.	B1	L	for clamping screw metric	for clamping screw inch	A	B2	B3	E1	E2	Weight [g]
70003	6,6	50	M6	1/4	10	20	8	10	20	63
70011	9	60	M8	5/16	12	25	10	13	22	113
70029	11	80	M10	3/8	15	30	12	15	30	226
70037	14	100	M12 M14	1/2	20	40	14	21	40	490
70045	14	125	M12 M14	1/2	20	40	14	21	50	621
70052	18	125	M16 M18	5/8	25	50	18	26	45	960
70060	18	160	M16 M18	5/8	25	50	18	26	65	1240
70078	22	160	M20 M22	3/4	30	60	22	30	60	1787
70086	22	200	M20 M22	3/4	30	60	22	30	80	2237
70094	26	200	M24	1	30	70	26	35	80	2580
70102	26	250	M24	1	35*	70	26	35	105	3800
70110	33	250	M30	1 1/4	40	80	34	45	100	4934
70128	33	315	M30	1 1/4	50	80	34	45	130	7788
70136	43*	400	M36 M42	1 1/2 1 5/8	60	100	43	100	150	15000

\* Size not included in DIN, dimensions similar to DIN

### Recommendations



DIN 787,  
page 94

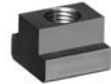

DIN 508,  
page 104



DIN 6331,  
page 108

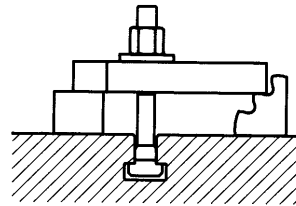

CAD



Subject to technical alterations.

## No. 6314Z

### Step clamp

Tempering steel, varnished.  
Only match step blocks no. 6500E. The longer versions are used for large clamping distances due to large T-slot distance or enlarged work depth, i.e. on graving machines.

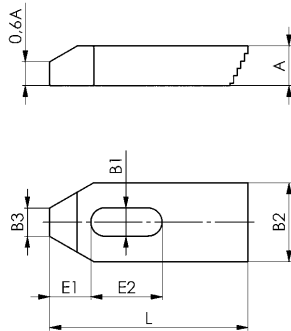

Order no.	B1	L	for clamping screw metric	for clamping screw inch	A	B2	B3	E1	E2	Weight [g]
70359	6,6	50	M6	1/4	10	20	8	10	20	55
70227	6,6	80	M6	1/4	10	20	8	10	45	90
70367	9	60	M8	5/16	12	25	10	13	22	100
70243	9	100	M8	5/16	12	25	10	13	60	180
70375	11	80	M10	3/8	15	30	12	15	30	200
70235	11	125	M10	3/8	15	30	12	15	70	350
70383	14	100	M12 M14	1/2	20	40	14	21	40	450
70250	14	160	M12 M14	1/2	20	40	14	21	90	770
70391	18	125	M16 M18	5/8	25	50	18	26	45	900
70334	18	200	M16 M18	5/8	25	50	18	26	110	1500
70409	22	160	M20 M22	3/4	30	60	22	30	60	1700
70417	26	200	M24	1	30	70	26	35	80	2500

### Recommendations



No. 6500E, page 50



No. 6379I, page 102

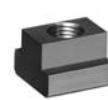

DIN 508, page 104

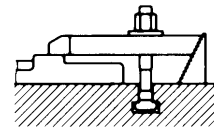
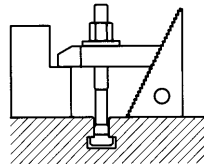

## DIN 6315B

### Forked clamp tapered

Tempering steel, varnished.

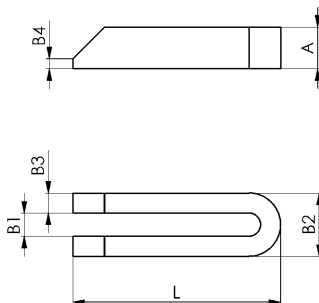

Order no.	B1	L	for clamping screw metric	for clamping screw inch	A	B2	B3	B4	Weight [g]
70466	6,6	60	M6	1/4	12	19	6	3	60
70474	9	80	M8	5/16	15	25	8	4	140
70482	11	100	M10	3/8	20	31	10	5	300
70490	14	125	M12 M14	1/2	25	38	12	6	570
70508	14	160	M12 M14	1/2	25	38	12	6	730
70516	14	200	M12 M14	1/2	25	38	12	6	910
70524	18	160	M16 M18	5/8	30	48	15	8	1080
70532	18	200	M16 M18	5/8	30	48	15	8	1360
70540	18	250	M16 M18	5/8	40	48	15	10	2250
70557	22	200	M20 M22	3/4	40	52	15	10	1800
70565	22	250	M20 M22	3/4	40	62	20	10	3000
70573	22	315	M20 M22	3/4	40	62	20	10	3850
70425	22 *	500	M20 M22	3/4	50	62	20	10	7500
70581	26	200	M24	1	40	66	20	10	2400
70599	26	250	M24	1	40	66	20	10	3000
70607	26	315	M24	1	40	66	20	10	3850
37390	26 *	400	M24	1	50	66	20	10	5962
70433	26 *	500	M24	1	50	66	20	10	7600
3079	26 *	600	M24	1	50	66	20	10	9042
30064	26 *	800	M24	1	50	66	20	10	12122
70615	33	250	M30	1 1/4	50	74	20	12	3700
70623	33	315	M30	1 1/4	50	74	20	12	4750
70631	33	400	M30	1 1/4	50	74	20	12	6100
70441	33 *	600	M30	1 1/4	50	74	20	12	9200
70458	33 *	1000	M30	1 1/4	60	94	30	12	28000
70649	40 *	400	M36	1 1/2	60	100	30	12	11000
70656	40 *	600	M36	1 1/2	60	100	30	12	16500
70672	43 *	600	M36 M42	1 1/2 1 5/8	80	123	40	12	29600

\* Size not included in DIN, dimensions similar to DIN

### Recommendations



DIN 787, page 94

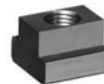

DIN 508, page 104



DIN 6331, page 108

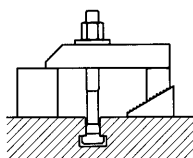

Subject to technical alterations.

## No. 6315GN

### Forked clamp with shoe

Tempering steel, varnished.

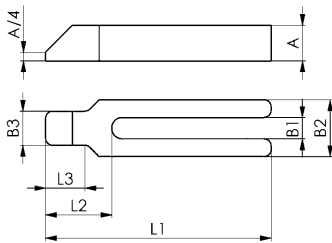

Order no.	B1	L1	for clamping screw metric	for clamping screw inch	A	B2	B3	L2	L3	Weight [g]
70862	9	100	M8	5/16	15	30	16	32	18	240
70870	11	125	M10	3/8	20	30	20	38	24	380
70888	14	160	M12 M14	1/2	25	40	24	47	30	800
70896	14	200	M12 M14	1/2	25	40	24	47	30	950
70904	18	200	M16 M18	5/8	30	50	28	57	36	1500
70912	18	250	M16 M18	5/8	30	50	28	57	36	1850
70920	22	250	M20 M22	3/4	40	60	35	68	45	2900
70938	22	315	M20 M22	3/4	40	60	35	68	45	3600
70946	26	250	M24	1	40	70	43	83	56	3400
70953	26	315	M24	1	40	70	43	83	56	4300
70961	33	315	M30	1 1/4	50	80	50	88	56	6000
70979	33	400	M30	1 1/4	50	80	50	88	56	7300

#### Recommendations



DIN 787, page 94



DIN 508, page 104



DIN 6331, page 108



## No. 6315NGG

### Clamp with nose, closed

Infinitely adjustable, tempered and painted, with closed slot for use with rotating workpieces

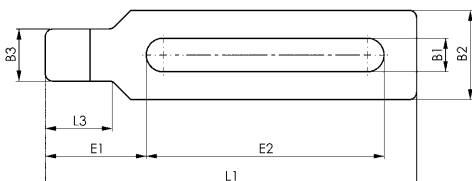
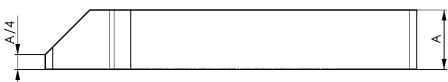

Order no.	B1	L	for clamping screw metric	for clamping screw inch	A	B2	B3	E1	E2	L3	Weight [g]
376145	22	250	M20 M22	3/4	40	60	35	68	160	45	3025
376160	22	315	M20 M22	3/4	40	60	35	68	220	45	3810
376186	22	400	M20 M22	3/4	50	60	35	68	300	45	5995
376202	22	500	M20 M22	3/4	50	60	35	68	400	45	7440
376228	26	250	M24	1	40	70	43	83	140	56	3639
376244	26	315	M24	1	40	70	43	83	200	56	4560
376269	26	400	M24	1	50	70	43	83	270	56	7243
376285	26	500	M24	1	50	70	43	83	370	56	8937
376301	33	315	M30	1 1/4	50	80	50	88	200	56	6367
376327	33	400	M30	1 1/4	50	80	50	88	283	56	7798
376343	33	500	M30	1 1/4	50	80	50	88	383	56	9607

#### Recommendations



DIN 787, page 94



DIN 508, page 104



DIN 6331, page 108



Subject to technical alterations.

## DIN 6315C

### Forked clamp with pin end

Tempering steel, varnished.

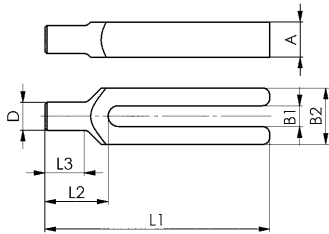

Order no.	B1	L1	for clamping screw metric	for clamping screw inch	A	B2	D	L2	L3	Weight [g]
70706	9	100	M8	5/16	15	30	12	30	18	220
70714	11	125	M10	3/8	20	30	16	36	24	350
70722	14	160	M12 M14	1/2	25	40	20	45	30	750
70730	14	200	M12 M14	1/2	25	40	20	45	30	950
70748	18	200	M16 M18	5/8	30	50	24	55	36	1400
70755	18	250	M16 M18	5/8	30	50	24	55	36	1750
70763	22	250	M20 M22	3/4	40	60	30	65	45	2700
70771	22	315	M20 M22	3/4	40	60	30	65	45	3400
70789	26	250	M24	1	40	70	38	80	56	3200
70797	26	315	M24	1	40	70	38	80	56	4100
70805	33	315	M30	1 1/4	50	80	45	85	56	5700
70813	33	400	M30	1 1/4	50	80	45	85	56	7000

#### Recommendations



DIN 787, page 94

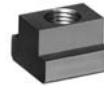

DIN 508, page 104



DIN 6331, page 108



## DIN 6316

### Clamp, cranked

Tempering steel, varnished.

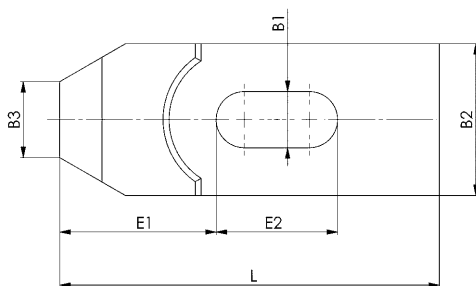
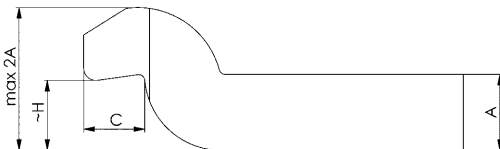

Order no.	B1	L	for clamping screw metric	for clamping screw inch	A	B2	B3	C	E1	E2	H	Weight [g]
71027	6,6	60	M6	1/4	10	20	10	8	20	20	9	81
71035	9	80	M8	5/16	12	25	12	9	25	25	11	166
71043	11 *	100	M10	3/8	15	30	15	12	32	32	14	299
71050	14	125	M12 M14	1/2	20	40	20	16	40	40	18	678
71068	18 *	125	M16 M18	5/8	25	50	25	20	49	40	23	1049
71076	18	160	M16 M18	5/8	25	50	25	20	49	50	23	1366
71084	22 *	160	M20 M22	3/4	30	60	30	24	55	55	27	1911
71092	22	200	M20 M22	3/4	30	60	30	24	55	70	27	2417
71100	26 *	200	M24	1	35	70	35	25	72	60	32	3315
71118	26 *	250	M24	1	35	70	35	25	72	80	32	4132
71126	33 *	250	M30	1 1/4	40	80	40	40	91	80	45	5225
71134	33	315	M30	1 1/4	50	80	40	40	91	100	45	8459
71159	43 *	400	M36 M42	1 1/2 1 5/8	60	100	50	50	105	120	55	17078

\* Size not included in DIN, dimensions similar to DIN

#### Recommendations



DIN 787, page 94

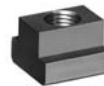

DIN 508, page 104



DIN 6331, page 108



Subject to technical alterations.

## No. 6317

### Double goose-neck clamp

Tempering steel, varnished.

Order no.	B1	L	for clamping screw	A	B2	B3	C	E	H	Weight [g]
71340	18	100	M12-M18	20	40	20	16	26	40	620
71357	25	140	M20-M24	30	60	30	24	38	60	2040

For use with washers DIN 6340 or DIN 6319G.

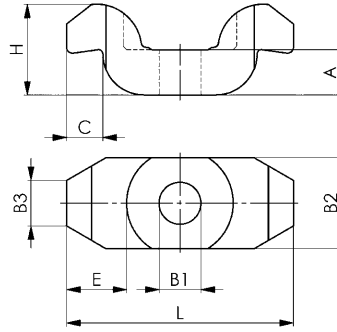

#### Recommendations



CAD



## No. 6317K

### Clamp, double (short)

tempered.

Order no.	Size	A [mm]	B1 [mm]	B2 [mm]	C [mm]	E1 [mm]	E2 [mm]	G [mm]	L [mm]	Weight [g]
78956	12	15	12,5	30	13,5	23,5	33	M12	80	200
78972	16	25	17,0	40	16,0	29,0	42	M16	100	525

#### Note:

For pressure screws that fit, see accessories.

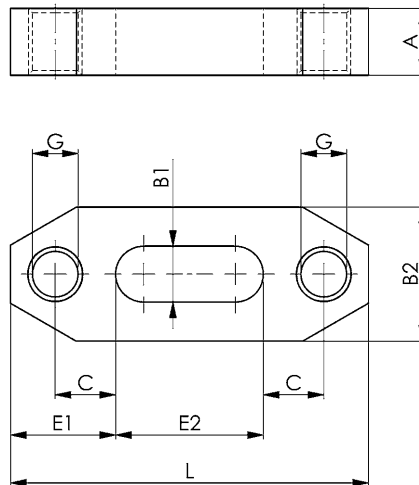

Subject to technical alterations.

## No. 6365-\*\*-009

**Clamp, double**  
tempered.

Order no.	Size	A	B	E	F	Weight [g]
78626	12	20	30	48	14	192
78667	16	25	40	62	18	385

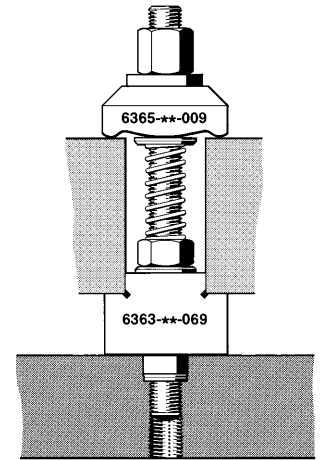
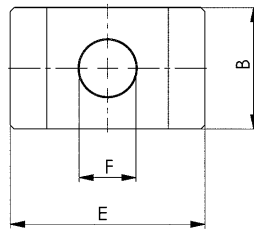
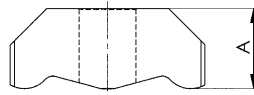

## No. 6325

### Clamps for machine vices

Tempered steel, milled, quenched in blue oxide finish. Packaged in pairs.

Order no.	H	B1	L	for clamping screw metric	for clamping screw inch	A	A1	A2	B2	E1	E2	Weight [g]
74682	15	16,5	78	M12, 14, 16	1/2, 5/8	22,5	10	6,5	40	10,5	40	660
74690	20	16,5	78	M12, 14, 16	1/2, 5/8	27,5	10	6,5	40	10,5	40	705

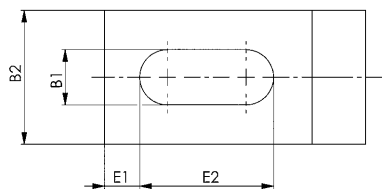
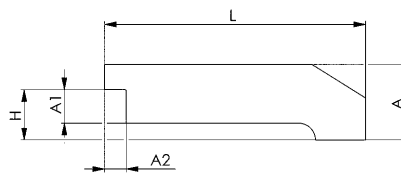
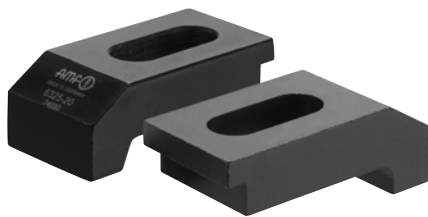

### Recommendations



DIN 787,  
page 94



No. 63791,  
page 102



DIN 508,  
page 104

CAD



Subject to technical alterations.

## No. 6314V

### Tapered clamp with adjusting support screw

(without clamping stud)  
Painted tempered steel.



Order no.	for clamping screw	H*	sim. DIN6314 B1 x L	D x LS	A	B2	E1	E2	Weight [g]
70177	M10	8-37	11x80	M10x39	15	30	15	30	200
70193	M12 M14	10-47	14x100	M12x49	20	40	21	40	560
70821	M12 M14	10-92	14x100	M12x94	20	40	21	40	635
70219	M16 M18	13-52	18x125	M16x55	25	50	26	45	1110
70839	M16 M18	13-87	18x125	M16x90	25	50	26	45	1230
70201	M20 M22	16-65	22x160	M20x69	30	60	30	60	2050
70847	M20 M22	16-105	22x160	M20x109	30	60	30	60	2230
70151	M24	20-83	26x200	M24x87	30	70	35	80	3200
70854	M24	20-133	26x200	M24x137	30	70	35	80	3470
373928	M24	20-80	26x250	M24x87	35	70	35	105	4340
373936	M24	20-130	26x250	M24x137	35	70	35	105	4520
374405	M30	24-150	33x315	M30x180	50	80	45	130	11215
374439	M36 M42	24-150	43x400	M30x180	80	100	80	170	24350

\*depending on depth of slot to DIN 650 and position of fixture nut.  
Clamps without T-bolts are same item for sizes 12 and 14, 16 and 18, 20 and 22, each.

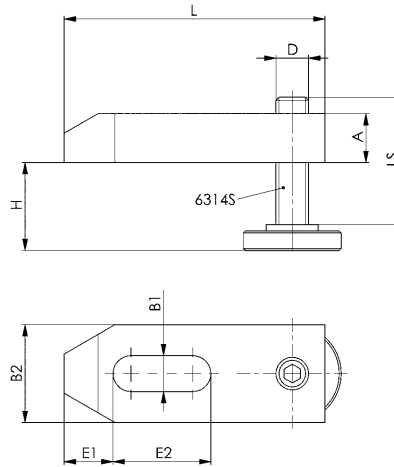

## No. 6314V

### Tapered clamp with adjusting support screw, complete

with DIN 787, DIN 6340, DIN 6330B. Painted tempered steel.



Order no.	Slot	with clamping stud	H*	sim. DIN6314 B1 x L	D x LS	A	B2	E1	E2	Weight [g]
70268	10	M10x10x80	8-32	11x80	M10x39	15	30	15	30	340
70276	12	M12x12x100	10-40	14x100	M12x49	20	40	21	40	700
72801	12	M12x12x160	24-92	14x100	M12x94	20	40	21	40	830
70284	14	M12x14x100	10-38	14x100	M12x49	20	40	21	40	720
72827	14	M12x14x160	23-92	14x100	M12x94	20	40	21	40	845
70292	16	M16x16x125	13-48	18x125	M16x55	25	50	26	45	1400
72942	16	M16x16x160	15-83	18x125	M16x90	25	50	26	45	1610
70300	18	M16x18x125	13-46	18x125	M16x55	25	50	26	45	1400
73056	18	M16x18x160	13-81	18x125	M16x90	25	50	26	45	1630
70326	20	M20x20x160	16-65	22x160	M20x69	30	60	30	60	2600
73064	20	M20x20x200	21-105	22x160	M20x109	30	60	30	60	2930
70318	22	M20x22x160	16-65	22x160	M20x69	30	60	30	60	2770
73072	22	M20x22x200	19-105	22x160	M20x109	30	60	30	60	2980
373944	28	M24x28x200	20-80	26x250	M24x87	35	70	35	105	5486
373951	28	M24x28x250	30-130	26x250	M24x137	35	70	35	105	5716
381988	36	M30x36x315	24-150	33x315	M30x180	50	80	45	130	11995
382002	42	M36x42x400	24-150	43x400	M30x180	80	100	80	170	25683

\*depending on depth of slot to DIN 650 and position of fixture nut.  
Clamps without T-bolts are same item for sizes 12 and 14, 16 and 18, 20 and 22, each.

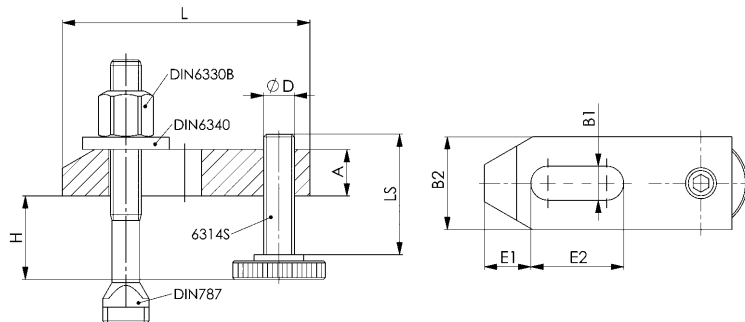

#### Recommendations



No. 6621,  
page 42



Subject to technical alterations.

## No. 6316V

### Cranked clamp with adjusting support screw

(without clamping stud)  
Painted tempered steel.



Order no.	for clamping screw	H*	sim. DIN6316 B1 x L	D x LS	A	B2	E1	E2	Weight [g]
71183	M10	22-51	11x100	M10x39	15	30	32	32	344
71209	M12 M14	28-65	14x125	M12x49	20	40	40	40	761
71225	M16 M18	36-75	18x160	M16x55	25	50	49	50	1516
71217	M20 M22	43-92	22x200	M20x69	30	60	55	70	2669
71266	M24	52-115	26x200	M24x87	35	70	72	60	3810

\*depending on depth of slot to DIN 650 and position of fixture nut.

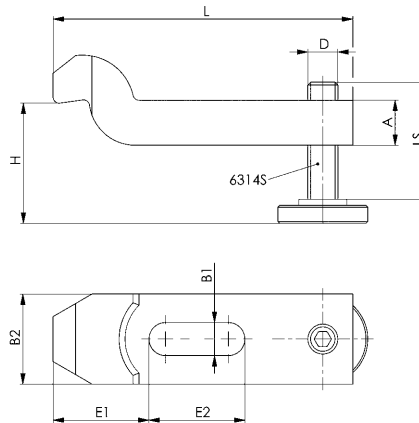

## No. 6316V

### Cranked clamp with adjusting support screw, complete

with DIN 787, DIN 6340, DIN 6330B.  
Painted tempered steel.



Order no.	Slot	with clamping stud	H*	sim. DIN6316 B1 x L	D x LS	A	B2	E1	E2	Weight [g]
71274	10	M10x10x80	22-46	11x100	M10x39	15	30	32	32	440
71282	12	M12x12x100	28-58	14x125	M12x49	20	40	40	40	906
71290	14	M12x14x100	28-56	14x125	M12x49	20	40	40	40	926
71308	16	M16x16x125	36-71	18x160	M16x55	25	50	49	50	1859
71316	18	M16x18x125	36-69	18x160	M16x55	25	50	49	50	1875
71332	20	M20x20x160	43-92	22x200	M20x69	30	60	55	70	3322
71324	22	M20x22x160	43-92	22x200	M20x69	30	60	55	70	3352

\*depending on depth of slot to DIN 650 and position of fixture nut.

Clamps without T-bolts are same item for sizes 12 and 14, 16 and 18, 20 and 22, each.

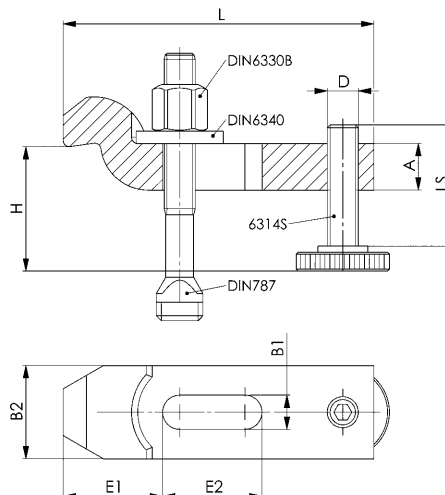

## No. 6314AV

### Stepped clamp with adjusting support screw

(without clamping stud)  
Painted tempered steel.



Order no.	for clamping screw	H*	sim. DIN6314 B1 x L	D x LS	A	A1xA2	B2	E1	E2	Weight [g]
74567	M12, M14	10-55	14x100	M12x49	20	8 x10,0	40	21	40	580
74575	M16, M18	13-62	18x125	M16x55	25	10x12,5	50	26	45	1140
74583	M20, M22	16-77	22x160	M20x69	30	12x15,0	60	30	60	2100

\*depending on depth of slot to DIN 650 and position of fixture nut.  
To clamp thin parts, turn the clamp over.

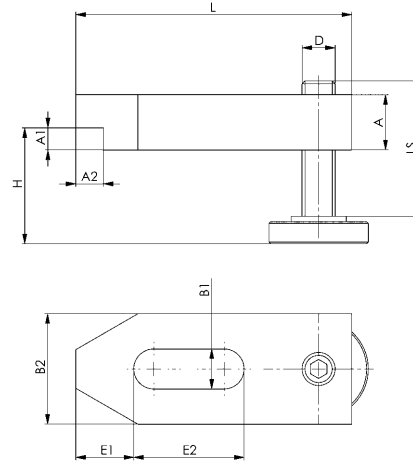

CAD

## No. 6314AV

### Stepped clamp with adjusting support screw, complete

with DIN 787, DIN 6340, DIN 6330B.  
Painted tempered steel.



Order no.	Slot	with clamping stud	H*	sim. DIN6314 B1 x L	D x LS	A	A1xA2	B2	E1	E2	Weight [g]
74591	12	M12x12x100	10-48	14x100	M12x49	20	8 x10,0	40	21	40	745
74625	14	M12x14x100	10-46	14x100	M12x49	20	8 x10,0	40	21	40	764
74633	16	M16x16x125	13-58	18x125	M16x55	25	10x12,5	50	26	45	1510
74641	18	M16x18x125	13-56	18x125	M16x55	25	10x12,5	50	26	45	1530
74658	20	M20x20x160	16-77	22x160	M20x69	30	12x15,0	60	30	60	2800
74666	22	M20x22x160	16-77	22x160	M20x69	30	12x15,0	60	30	60	2840

\*depending on depth of slot to DIN 650 and position of fixture nut.  
To clamp thin parts, turn the clamp over.  
Clamps without T-bolts are same item for sizes 12 and 14, 16 and 18, 20 and 22, each.

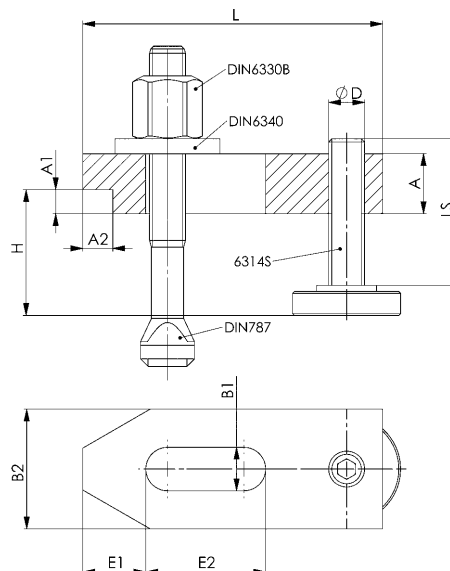

CAD

Subject to technical alterations.

## No. 6315V

### Stepped clamp with adjusting support screw

(without clamping stud)  
Painted tempered steel.

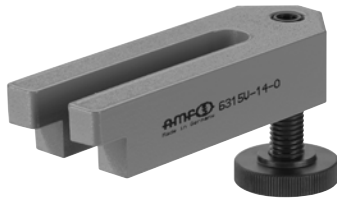

Order no.	for clamping screw	H*	sim. DIN 6315B B1 x L	D x LS	A	B2	E2	Weight [g]
71167	M10	8-47	11x100	M10x39	20	30	70	330
71175	M12 M14	10-59	14x125	M12x49	25	40	90	700
71191	M16 M18	13-67	18x160	M16x55	30	50	110	1300
71258	M20 M22	16-85	22x200	M20x69	40	60	135	2600

\*depending on depth of slot to DIN 650 and position of fixture nut.  
To clamp thin parts, turn the clamp over.

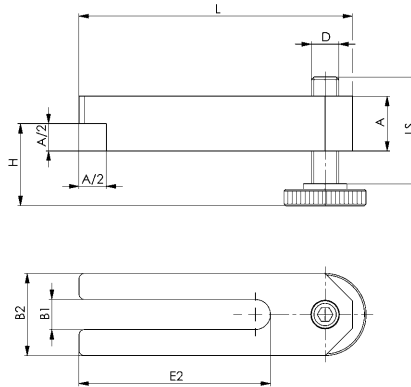

#### Recommendations



No. 6342,  
page 119



## No. 6315V

### Stepped clamp with adjusting support screw, complete

with DIN 787, DIN 6340, DIN 6330B.  
Painted tempered steel.



Order no.	Slot	with clamping stud	H*	sim. DIN 6315B B1 x L	D x LS	A	B2	E2	Weight [g]
73189	10	M10x10x 80	8-37	11x100	M10x39	20	30	70	403
73197	12	M12x12x100	10-48	14x125	M12x49	25	40	90	920
73205	14	M12x14x100	10-45	14x125	M12x49	25	40	90	940
73247	16	M16x16x125	13-58	18x160	M16x55	30	50	110	1860
73254	18	M16x18x125	13-56	18x160	M16x55	30	50	110	1880
73262	20	M20x20x160	16-77	22x200	M20x69	40	60	135	3610
73288	22	M20x22x160	16-75	22x200	M20x69	40	60	135	3650

\*depending on depth of slot to DIN 650 and position of fixture nut.  
To clamp thin parts, turn the clamp over.  
Clamps without T-bolts are same item for sizes 12 and 14, 16 and 18, 20 and 22, each.

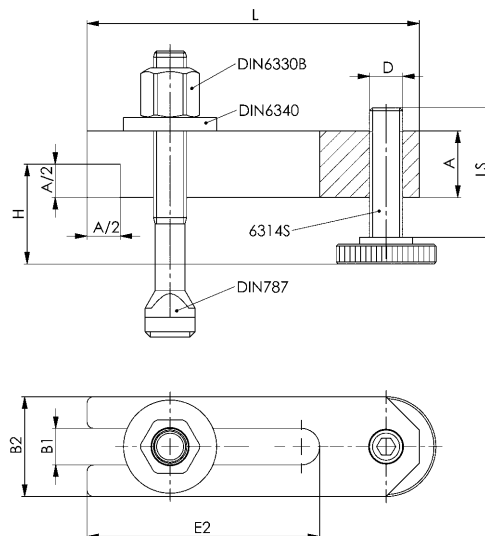

## No. 6313K

### Clamp, short, with U-piece

(without clamping bolt)  
continuously adjustable, tempered and galvanized.



Order no.	Size	for clamping screw	H1	B1	B2 x L	D	E1	E2	H2	K	Weight [g]
73932	13	M12	0-35	13	38x88	48	23	28	30-55	14	260
73940	18	M16	0-55	18	56x130	74	29	38	42-84	18	809
73957	22	M20	0-65	22	66x144	80	32	46	50-100	20	1253
73965	26	M24	0-75	25	76x174	100	39	52	54-111	24	1718
73973	32	M30	0-80	31	90x200	110	44	61	62-125	28	2785

#### Note:

Suitable fastening elements: DIN 787 clamping bolts, DIN 6340 washers and DIN 6330B hexagon nuts.

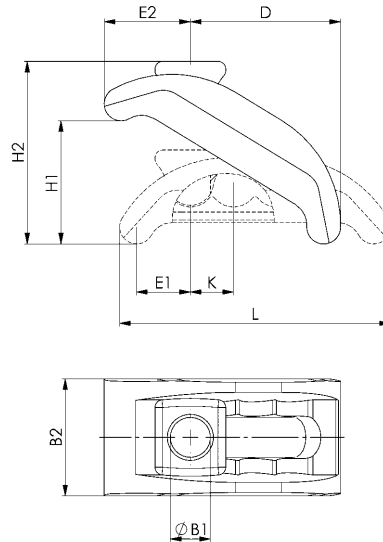

## No. 6313K

### Clamp, short, with U-piece, complete

with DIN 787, DIN 6340, DIN 6330B.  
continuously adjustable, tempered and galvanized.



Order no.	Slot	with clamping stud	H1	B1	B2 x L	D	E1	E2	H2	K	Weight [g]
77149	12	M12x12x100	0-35	13	38x88	52	23	27	30-55	14	395
77156	14	M12x14x100	0-35	13	38x88	52	23	27	30-55	14	415
77180	16	M16x16x160	0-55	18	56x130	79	29	37	42-84	18	1130
77198	18	M16x18x160	0-55	18	56x130	79	29	37	42-84	18	1550
77206	20	M20x20x200	0-65	22	66x144	84	32	42	50-100	20	1880

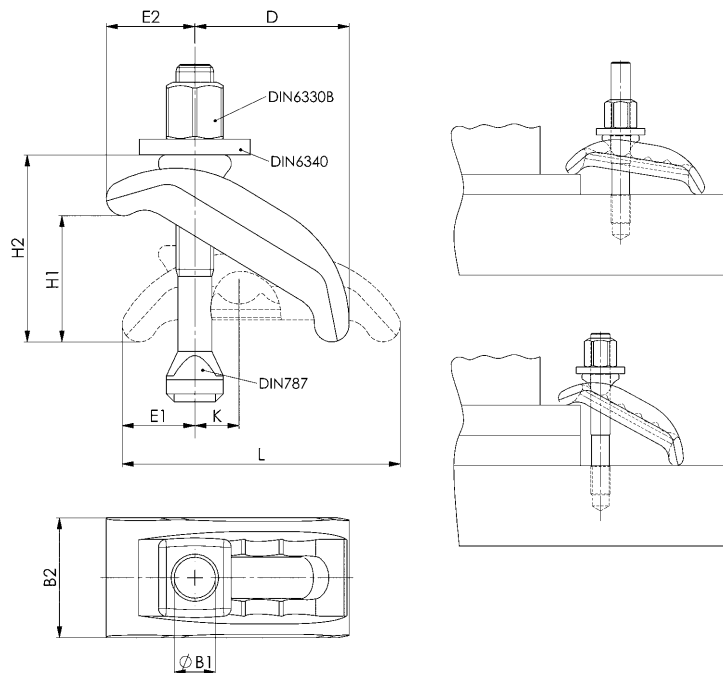

Subject to technical alterations.

## No. 6321

### Clamp, continuously adjustable

with U-piece. Steel, forged and tempered, galvanised.



Order no.	Size	for clamping screw	H	B1	B2 x L	D	E1	E2	Weight [g]
71522	17	M12, M14, M16	0-75	17	50x140	60	30	55	900
71530	21	M20	0-85	21	60x175	80	40	70	1600

### Application:

Stepless clamp for fast coverage of several ranges of work height without additional supports. Low space requirement on machine table. Heavy-duty design and specially suitable for clamping of press- and punching tools.

### Note:

Suitable fastening elements: DIN 787 clamping bolts, DIN 6340 washers and DIN 6330B hexagon nuts.

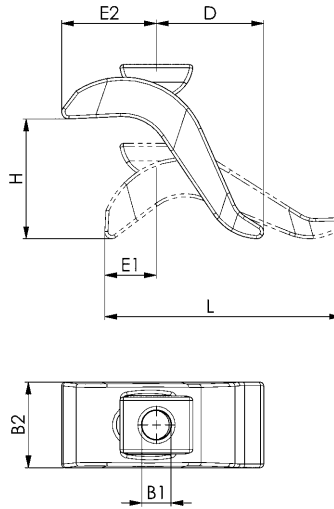

CAD



## No. 6321

### Clamp, continuously adjustable, complete

with DIN 787, DIN 6340, DIN 6330B and U-piece. Steel, forged and tempered, galvanised.



Order no.	Slot	with clamping stud	H	B1	B2 x L	D	E1	E2	Weight [g]
74906	12	M12x12x125	0-50	17	50x140	60	30	55	1070
74914	14	M12x14x125	0-50	17	50x140	60	30	55	1080
74922	16	M16x16x160	0-75	17	50x140	60	30	55	1270
74930	18	M16x18x160	0-75	17	50x140	60	30	55	1280
74971	20	M20x20x200	0-85	21	60x175	80	40	70	2300
74963	22	M20x22x200	0-85	21	60x175	80	40	70	2370

### Application:

Stepless clamp for fast coverage of several ranges of work height without additional supports. Low space requirement on machine table. Heavy-duty design and specially suitable for clamping of press- and punching tools.

### Note:

With the clamping jaw size 17 a maximum clamping height of 75 mm can be achieved with screws for T-slots DIN 787, length 160 mm.

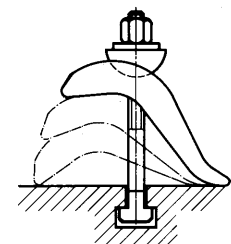
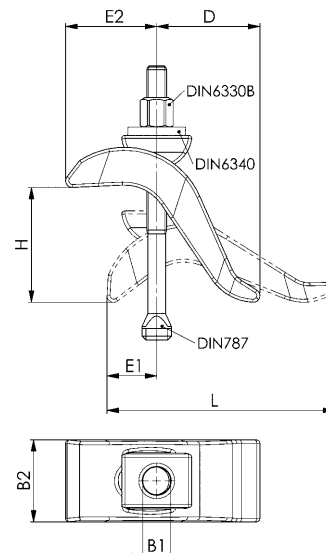

CAD



### Recommendations



No. 6312V,  
page 22



No. 6312VT,  
page 23

Subject to technical alterations.

## No. 6314S

### Support screw

Hardened, strength class 8.8 Suitable for all lockable clamps.

Order no.	D x LS	D1	K	Weight [g]
73437	M10x39	30	8	52
73445	M12x49	36	10	96
74039	M12x94	36	10	145
73452	M16x55	42	13	180
74047	M16x90	42	13	230
73460	M20x69	50	16	320
74054	M20x109	50	16	400
73478	M24x87	60	20	590
74062	M24x137	60	20	820
374413	M30x180	80	24	1704

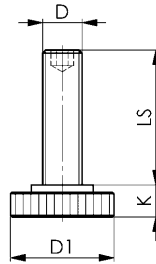

## No. 6621

### Detent clamp lever

Steel, blued. Suitable for adjustable clamps no. 6313K, 6314V, 6315V, 6316V and 6321.

Order no.	G	D	H	L	Weight [g]
74609	M12	33	48	135	360
74617	M16	40	64	158	620

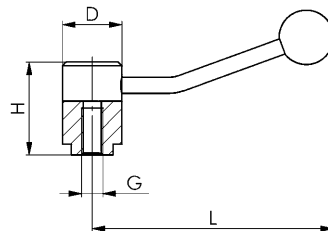

Subject to technical alterations.

## No. 7000

### Step clamp

Special cast iron, screw and bushing 8.8.



Order no.	Size	Slot	Clamping force max. * [kN]	Md [Nm]	B	C	H	L	S	Weight [g]
74716	12-1	12	11,4	50	34	14	15-45	112	0,75	600
74724	12-2	12	11,4	50	34	15	30-75	112	1,25	800
74732	12-3	12	11,4	50	34	16	60-135	112	2,50	1200
74740	12-4	12	11,4	50	34	18	120-195	112	2,50	1700
74757	12-5	12	11,4	50	34	19	180-255	112	2,50	2200
74765	14-0	14	15,5	80	34	14	0-45	140	0,75	700
74773	14-1	14	15,3	80	34	14	15-45	112	0,75	600
74781	14-2	14	15,3	80	34	15	30-75	112	1,25	800
74799	14-3	14	15,3	80	34	16	60-135	112	2,50	1200
74807	14-4	14	15,3	80	34	18	120-195	112	2,50	1700
74815	14-5	14	15,3	100	34	19	180-255	112	2,50	2200
74831	16-1	16	16,3	100	50	20	25-70	125	1,25	1700
74849	16-2	16	16,3	100	50	21	50-120	125	2,50	2500
74856	16-3	16	16,3	100	50	21	100-220	125	3,75	3540
74997	18-1	18	19,0	130	50	20	25-70	125	1,25	1670
75002	18-2	18	19,0	130	50	21	50-120	125	2,50	2500
75010	18-3	18	19,0	130	50	21	100-220	125	3,75	3580
75028	18-4	18	19,0	130	50	24	200-320	125	3,75	4750

\* Specified clamping forces in optimal clamping position (smallest distance of the clamping screw to the clamping position).

#### Application:

- thanks to the compact design the helical clamp requires little space on the machine table

#### Advantage:

- quickly ready
- The spiral serration allows fast adapting to any workpiece height up to approx. 320 mm

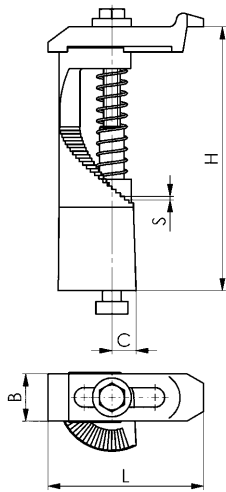

CAD



#### Recommendations



No. 6312V,  
page 22



No. 6312VT,  
page 23

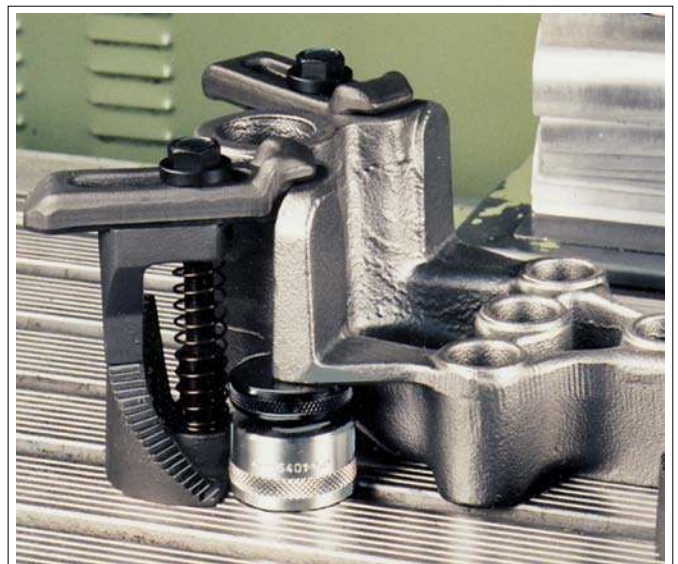

Subject to technical alterations.

## No. 6314AT

### Clamping unit to clamp outside of the tool table

Tempered steel. Infinitely adjustable.



Order no.	Clamping force [kN]	Tightening torque [Nm]	Slot	G	H	Weight [g]
73999	15	70	18	M12	20-35	840
73981	25	170	22	M16	30-45	2126
79194	50	320	28	M20	40-53	5000

### Application:

Used for clamping outside of the tool table. For use when clamping large workpieces or tools that do not allow any space for clamping elements on the tool or machine table.

### Note:

For the installation dimensions of the clamp, see No. 7110GX-\*\*-1. Do not use on presses!

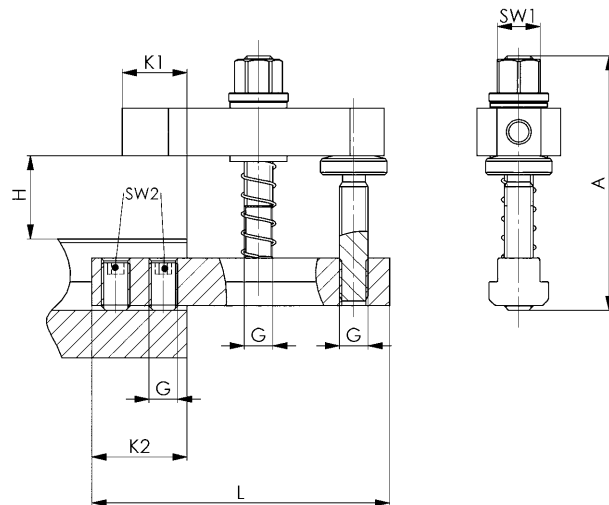

### Dimensions:

Order no.	A	L	K1	K2	SW1	SW2
73999	105	125	27	40	18	6
73981	168	165	35	55	24	8
79194	206	255	33	85	30	10



Subject to technical alterations.

CAD



## No. 7110GX-\*\*-1

**Clamp, straight**  
tempered.

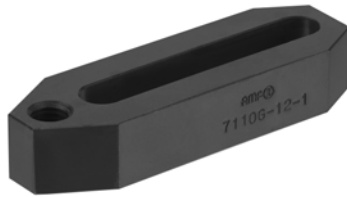

Order no.	Size	A x B	E	F	G	G1	I	K	N	Weight [g]
73528	12	20x35	110	12,5	M12	M10	21,5	11,5	82	340
73536	16	30x40	142	17,0	M16	M12	28,0	15,0	107	770
73544	20	40x50	200	21,0	M20	M16	38,0	21,0	150	1800

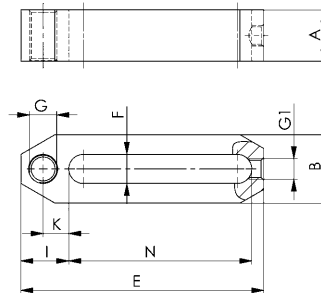

## No. 7110GLX-\*\*-1

**Clamp, straight (long)**  
with screw-in pin end tempered.



Order no.	Size	A x B	E	F	G	I	K	L	M	N	Weight [g]
73551	12	20x35,0	156	12,5	M12	30	20	12	18	106	600
73577	16	30x45,5	196	17,0	M16	35	22	16	24	136	1400
73585	20	40x60,0	298	21,0	M20	47	30	20	30	221	3900

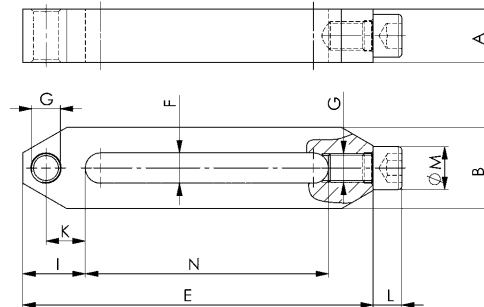

## No. 7110DX-\*\*xM\*\*

**Set screw**  
ball-shaped, strength class 10.9.



Order no.	Size	G	H	H1	L	R	SW	Weight [g]
73593	12	M12	7,5	16-28	30	60	19	50
73601	16	M16	10,0	20-38	40	75	24	100

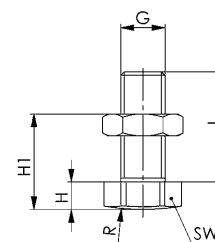

## No. 7110DMX-\*\*xM\*\*

**Set screw, brass**  
ball-shaped, with steel nut.



Order no.	Size	G	H	H1	L	R	SW	Weight [g]
73635	12	M12	7,5	16-28	30	60	19	50
73643	16	M16	10,0	20-38	40	75	24	100

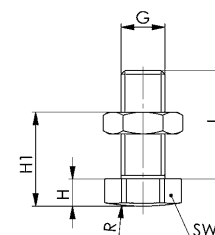

Subject to technical alterations.

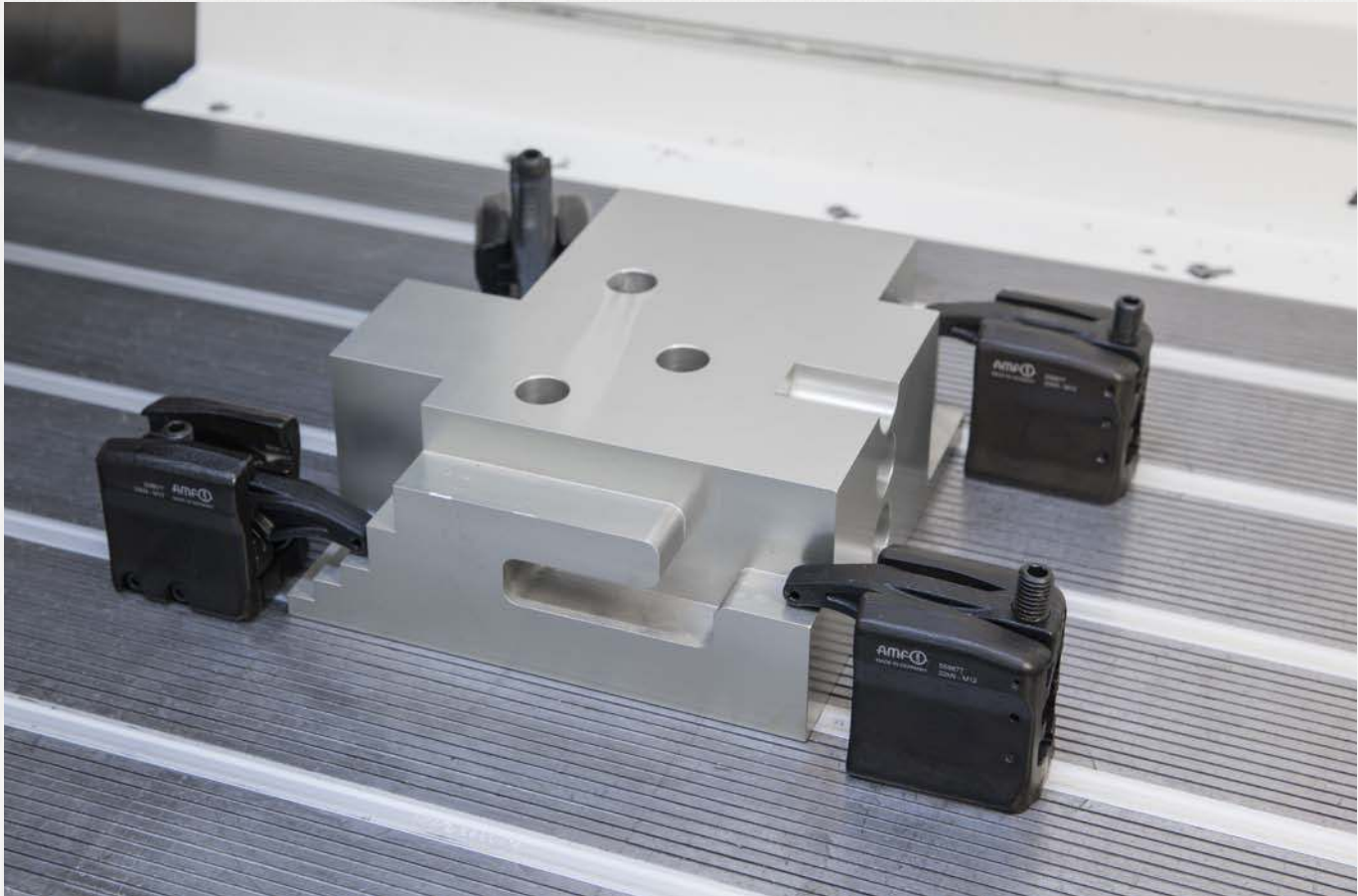

Subject to technical alterations.

## No. 7110DHX-\*\*xM\*\*

### Set screw with ball

Adjustable, ribbed, with nut ISO 4035.  
Flat-faced ball: ball bearing steel, hardened, ribbed  
body: tempered steel, tempered



Order no.	Size	G	H	dia. K	L	SW1	SW2	max. load static [kN]	Max. tightening torque [Nm]	Weight [g]
374447	M8	M8	11,6	5,8	25	13	13	8	25	20
73650	M12	M12	15,7	8,6	35	17	17	15	82	55
73668	M16	M16	20,7	10,5	40	24	24	25	206	128
73692	M20	M20	27,3	20,0	50	30	30	90	407	274

## No. 7110DIX-\*\*xM\*\*

### Set screw with ball

Adjustable, plain, with nut ISO 4035.  
Ball bearing: ball bearing steel, hardened, smooth  
body: tempered steel, tempered



Order no.	Size	G	H	dia. K	L	SW1	SW2	max. load static [kN]	Max. tightening torque [Nm]	Weight [g]
374454	M8	M8	11,6	5,8	25	13	13	8	25	20
73684	M12	M12	15,7	8,6	35	17	17	15	82	55
73718	M16	M16	20,7	10,5	40	24	24	25	206	128
73726	M20	M20	27,3	20,0	50	30	30	90	407	275

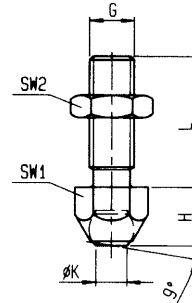

## No. 7110DKX-\*\*xM\*\*

### Set screw with ball, plain

Ball bearing: ball bearing steel, hardened, smooth  
body: tempered steel, tempered



Order no.	Size	G	H	dia. I	dia. K	L	SW	max. load static [kN]	Max. tightening torque [Nm]	Weight [g]
374462	M8	M8	13	13	7,2	8	11	10	25	13
568020	M10	M10	18	20	10,5	10	17	25	46	40
73734	M12	M12	18	20	10,5	12	17	25	82	43
73742	M16	M16	27	30	20,0	16	27	90	206	150
73759	M20	M20	35	50	34,5	20	41	165	407	486

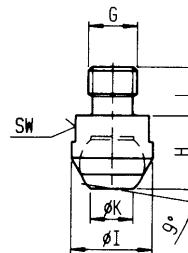

## No. 7110DFX-\*\*xM\*\*

### Set screw with flat-faced ball, ribbed

Flat-faced ball: ball bearing steel, hardened, ribbed  
body: tempered steel, tempered



Order no.	Size	G	H	dia. I	dia. K	L	SW	max. load static [kN]	Max. tightening torque [Nm]	Weight [g]
75432	M8	M8	13	13	7,2	8	11	10	25	13
568021	M10	M10	18	20	10,5	10	17	25	46	40
73767	M12	M12	18	20	10,5	12	17	25	82	43
73775	M16	M16	27	30	20,0	16	27	90	206	150
73783	M20	M20	35	50	34,5	20	41	165	407	486

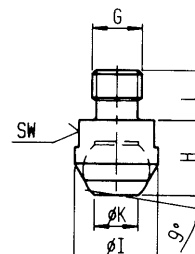

Subject to technical alterations.

## THE MOST IMPORTANT FACTS ABOUT SUPPORT BLOCKS

- > **Material:** High quality tempering steel resp. castings.
- > **Machining:** All support blocks shown, have machined base- and contact faces. The serrated elements are precisely milled or broached. Leveled work support and safe force transmission are therefore provided.
- > **Execution:** To DIN regulations.
- > **Finishing:** All support blocks are abrasionproof quality varnished.

The following pages contain suitable support blocks, finely graduated or infinitely adjustable, for any application. Support heights from 12.5 to 340 mm are achievable with all support blocks.

For clamping heights over 340 mm, we recommend our screw jacks on pages 66 to 67.

- > Conventional workpiece clamping for drilling and pinning a fixture.

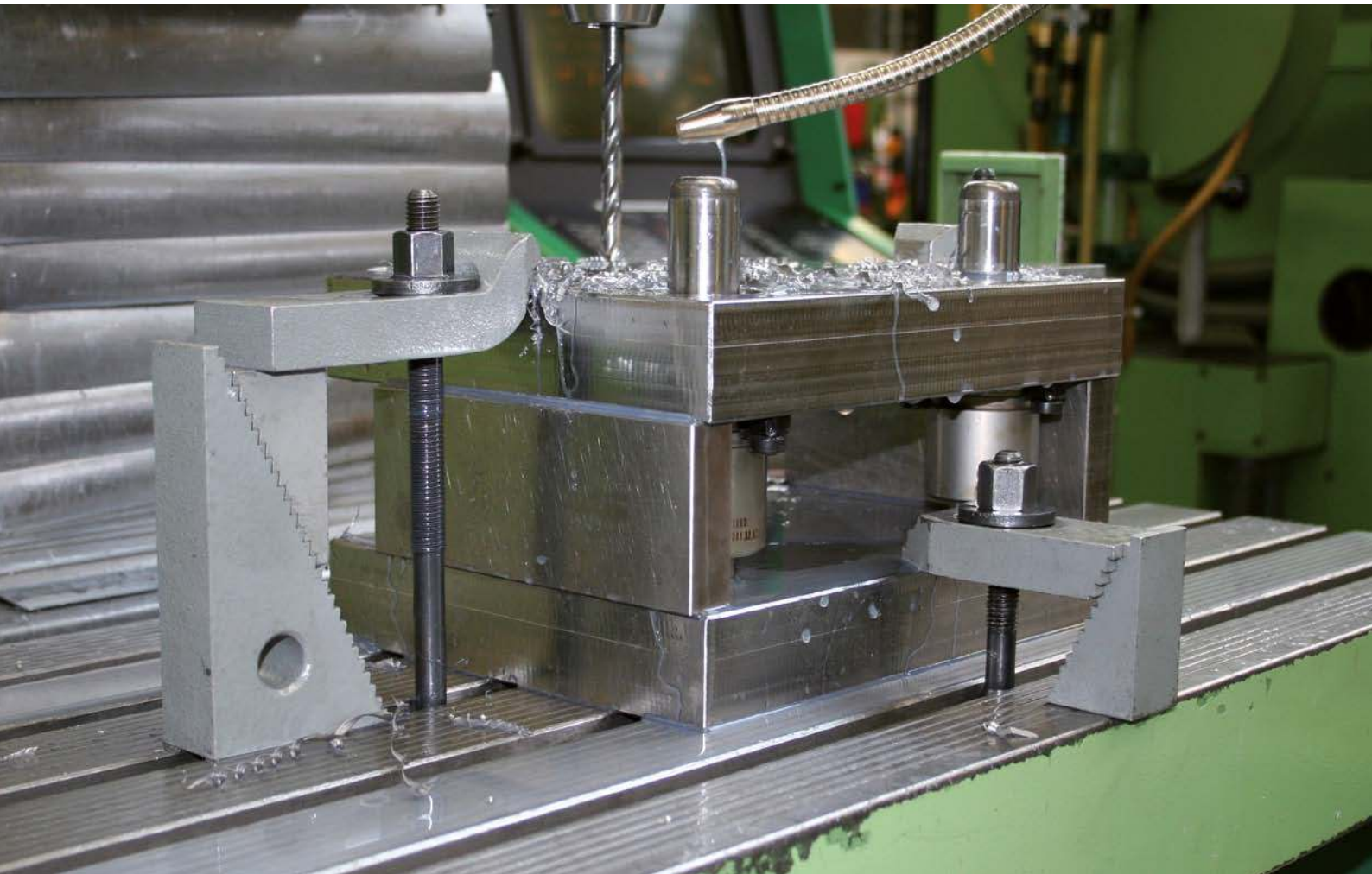

## DIN 6318

### Step blocks

with step increments of 7.5 mm each. Machine casting, varnished, base and step faces milled.



Order no.	Size	H min. [mm]	H max. [mm]	A	B1	B2	Weight [g]
71365	50	12,5	50	42,5	50	50	500
71373	95	57,5	95	95,0	55	50	1600
71381	140	102,5	140	100,0	60	50	2000
71399	185	147,5	185	105,0	65	50	2900
71407	230	192,5	230	110,0	70	50	3600
71415	275	237,5	275	115,0	75	50	4300
71423	320	282,5	320	120,0	80	50	5200

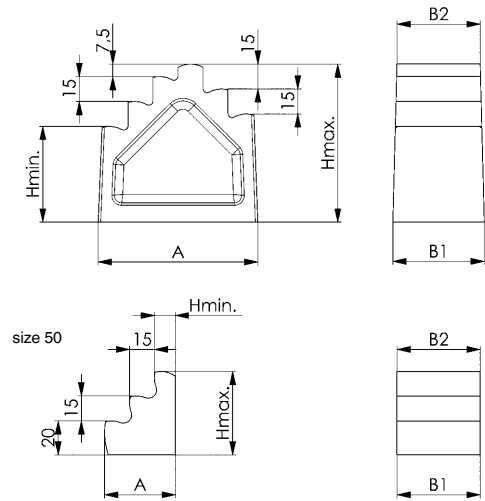

## No. 6318B

### Step blocks, wide

with step increments of 7.5 mm each. Machine casting, varnished, base and step faces milled.



Order no.	Size	H min. [mm]	H max. [mm]	A	B1	B2	Weight [g]
71480	50	12,5	50	42,5	80	80	800
71498	95	57,5	95	95,0	85	80	2300
71506	140	102,5	140	100,0	90	80	3450

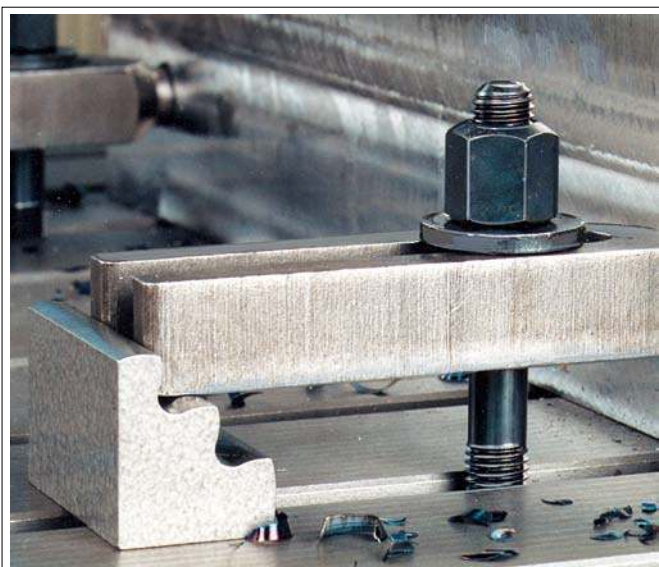
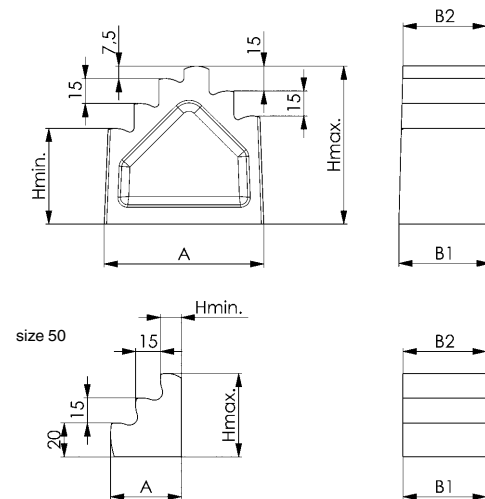

Subject to technical alterations.

## No. 6500E

### Universal step blocks

Step increments: vertical 4.65 mm, horizontal 2.3 mm.  
Tempering steel, varnished.

Order no.	Size	H min. [mm]	H max. [mm]	A	B	C	Weight [g]
73296	1	23	51	19,0	30	33	90
73304	2	39	107	35,5	30	66	300
73312	3	71	208	68,0	30	131	1050

### Application:

For use in pairs with all clamps and single use with clamp no. 6314Z.

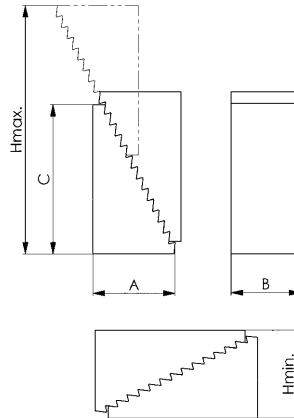

### Recommendations



No. 6314Z,  
page 31



No. 6501,  
page 51



## No. 6500H

### Universal step block set

in solid wooden case with lid.  
Tempering steel, varnished.

Order no.	Contents	H min. [mm]	H max. [mm]	Case L x B x H	Weight [Kg]
73346	8x6500E-1, 8x6500E-2, 4x6500E-3	23	208	280x155x40	8,4

### Application:

For use in pairs with all clamps and single use with clamp no. 6314Z.

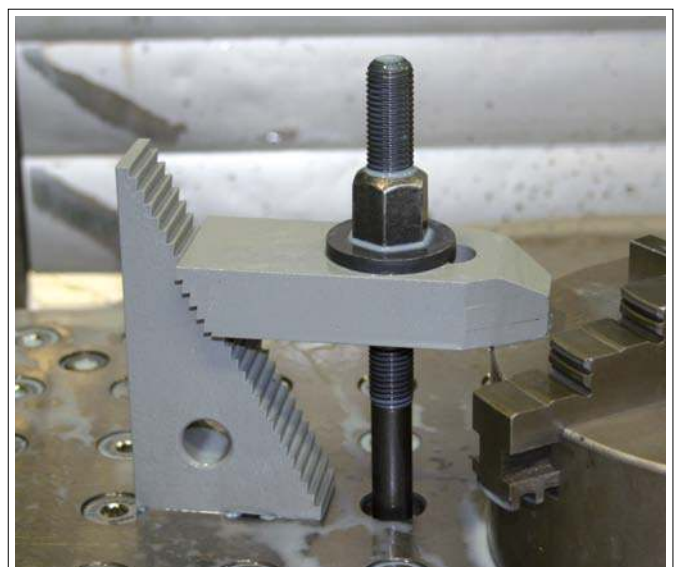

Subject to technical alterations.

## No. 6501

### Step block

contact face 60 mm wide. With link spring.  
 Step increments: vertical 4.65 mm, horizontal 2.3 mm.  
 Tempered steel, varnished.

Order no.	Size	H min. [mm]	H max. [mm]	B	Weight [g]
73353	2	37	107	60	1000

#### Note:

The two parts of this AMF-support blocks are linked with a spring for easy handling.

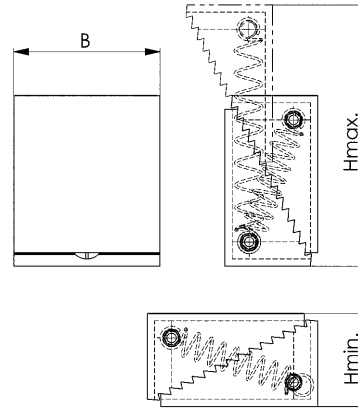

CAD



## No. 6501M

### Support block with magnet

Mounting surface 60 mm wide, with connecting spring.  
 Step increments: vertical 4.65 mm, horizontal 2.3 mm.  
 Tempered steel, burnished.

Order no.	Size	H min. [mm]	H max. [mm]	B	Weight [g]
373969	2	37	107	60	980

#### Note:

The two parts of this AMF support block are connected by a spring for ease of handling.  
 Holding force 4 magnets = 380 N  
 Holding force 2 magnets = 280 N

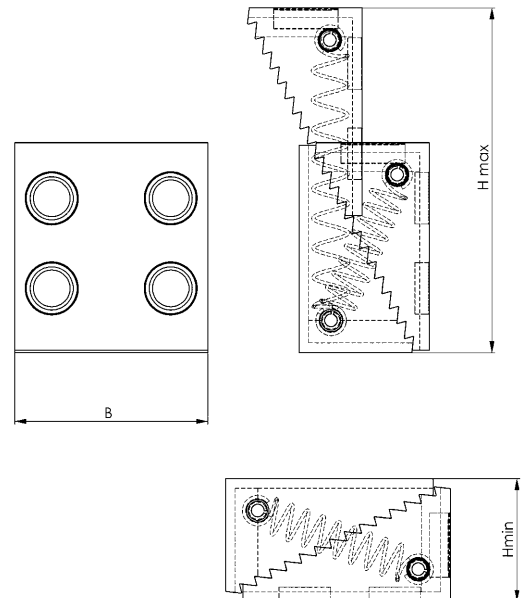

CAD



Subject to technical alterations.

## No. 6510

### Serrated heel block

(serrated jacks). Step increments: 5.2 mm. Malleable casting, varnished. Base mill finished.

Order no.	Size	H min. [mm]	H max. [mm]	A	B	F max. [kN]	Weight [g]
73379	2	111	147	50	50	40	1225
73387	3	155	223	60	60	60	2607
73395	4	220	340	80	80	90	6028



CAD

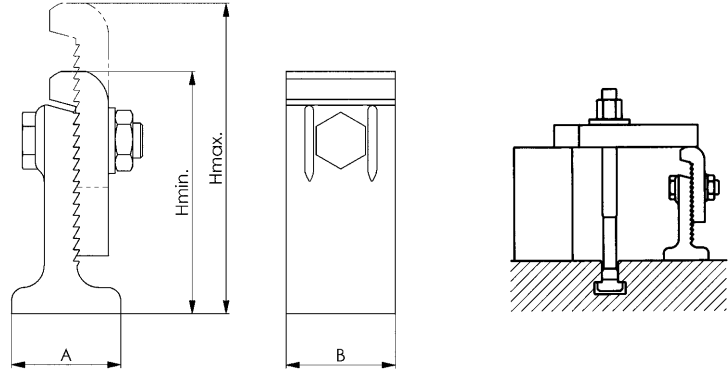

## DIN 6326

### Support blocks for continuous adjustment, combination

with spiral gearing. Tempering steel, varnished.



CAD



Order no.	Combination	H min. [mm]	H max. [mm]	Lower part	H1	Upper part	H2	Weight [g]
71969	AK	25	45	A	42	K	24	1050
71977	AG	45	65	A	42	G	44	1350
71985	BK	65	85	B	82	K	24	2500
71993	BG	85	105	B	82	G	44	2800
72009	CK	105	125	C	122	K	24	4000
72017	CG	125	145	C	122	G	44	4300
72025	AKG	25	65	A	42	K / G	24 / 44	1550
72033	BKG	65	105	B	82	K / G	24 / 44	3000
72041	CKG	105	145	C	122	K / G	24 / 44	4500

## DIN 6326

### Support blocks for continuous adjustment, single

with spiral gearing. Tempering steel, varnished.

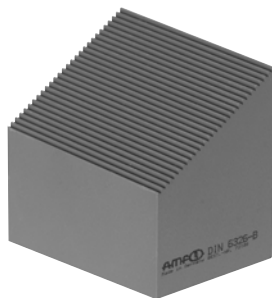

CAD



Order no.	Single parts	H1	H2	Weight [g]
72090	A	42	-	850
72108	B	82	-	2300
72116	C	122	-	3800
72124	K	-	24	200
72132	G	-	44	500

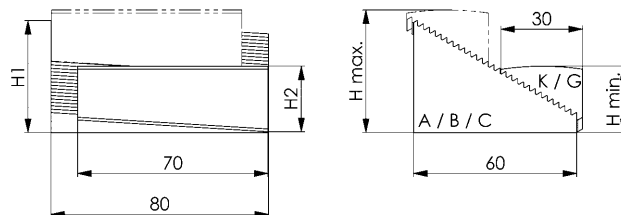

Subject to technical alterations.

## THE MOST IMPORTANT FACTS ABOUT SETTING ELEMENTS

Developed by AMF and proven in service for decades, these screw and aligning jacks offer a broad range of applications. Due to their robust construction, these screw jacks function securely and precisely, with stepless adjustment even under heavy loads.

### APPLICATIONS AND COMBINATIONS:

- > Safe and reliable clamp supports for heights from 38 to 1250 mm.
- > Accurate and safe supporting and setting of any workpiece in various levels and heights.
- > Aluminium screw jacks for delicate machine tables, surface plates and plane tables.
- > Magnetic screw jacks for horizontal and vertical supporting and setting.

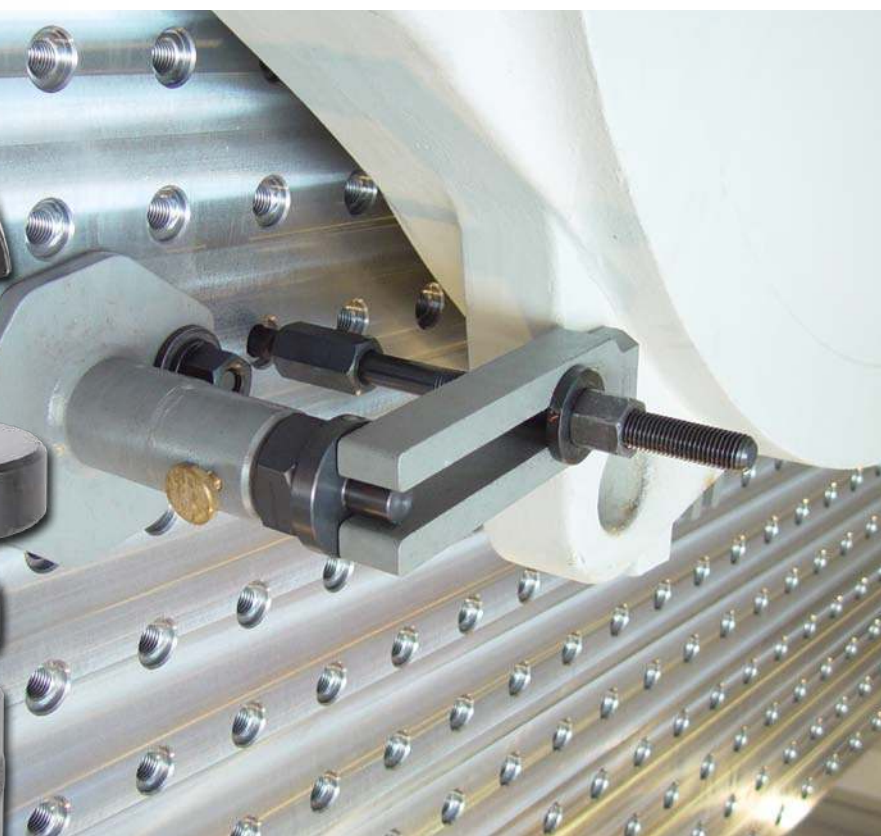

## SIMPLY CLEVERLY COMBINE – THE MODULAR SCREW JACK FROM AMF

With the modular screw jack from AMF your production becomes even more flexible and economical.

When cleverly combined, you can achieve a maximum height of 1620 mm. The screw jack can be used on T-slots and grid plates. The individual elements are plugged together, connected by means of a threaded ring ensuring process reliability and guarantee you maximum flexibility during the installation.

### THE BENEFITS:

- > The maximum height of 1620 mm is continuously adjustable and a height overlap is attainable.
- > The connecting points are protected against soiling.
- > Improved handling by means of individual elements.
- > Set-up time saving thanks to flexibility of parts.
- > Storage optimisation.

### SUPPORT ELEMENT WITH FINE THREAD

- > Used as an extra support point to prevent sagging and vibration of the workpiece.
- > Mounted directly under a clamping point, distortion of the workpiece is prevented.



**SCREW JACK ELEMENT**



**SPACER ELEMENTS**



**BASE ELEMENTS**



**THREAD ADAPTER**

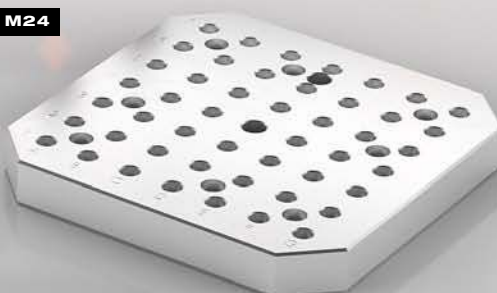

## No. 6425-706

### Screw jack, modular

Tempered steel, burnished.

Comprising:

- Screw jack element with base element 6425FB
- Spacer element 100 mm
- Spacer element 200 mm
- Thread adapter M16, M20, M24
- T-nuts groove 18, 22, 28
- Insertion tool



CAD

Order no.	TR	H min. [mm]	H max. [mm]	F max. [kN]	Weight [g]
562000	40 x 7	306	706	60	21481

### Application:

Can be used on T-slots and grid plates by means of adapters, which are screwed in the base element. The individual elements are plugged together and connected by means of a threaded ring ensuring process reliability. The threaded ring must not be retightened under load. The insertion tool makes it possible to use the head and base elements as well as thread adapter.

### Advantage:

- The maximum height of 1626 mm is continuously adjustable and a height overlap is attainable (with base element 6425FG or 6425FY).
- The connecting points are protected against soiling.
- Improved handling by means of individual elements.
- Set-up time saving thanks to flexibility of parts.
- Storage optimisation.

### Note:

- The modular design makes it possible to use different head and intermediate elements. Thus, a maximum height (with base element 6425FG or 6425FY) of 1626 mm with a permissible support force of 60 kN is possible. In addition, there is a risk of buckling.
- Do not adjust under load.



Focus Open 2020  
Gold

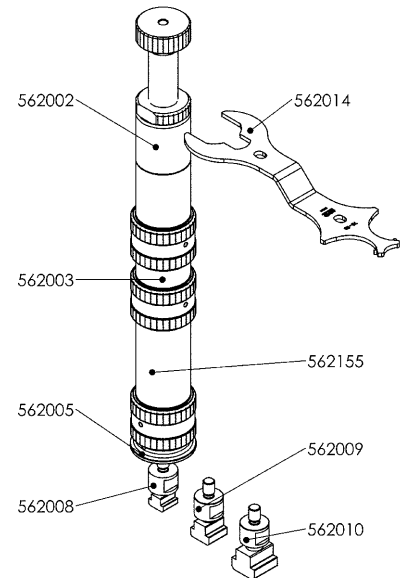
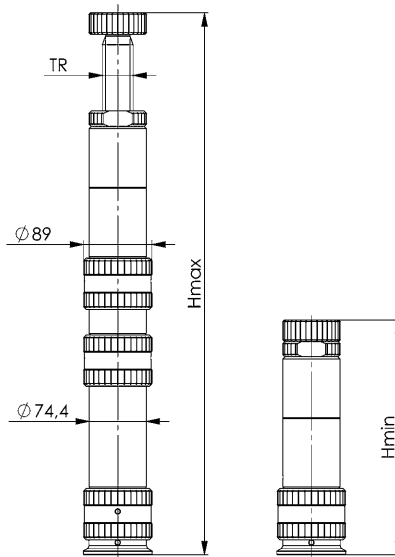

### Recommendations



No. 6425FY,  
page 59



No. 6425FG,  
page 59



No. 6425WW,  
page 62

Subject to technical alterations.

## No. 6425S-406

### Screw jack element with acme thread and base element 6425FB

with locknut for locking, centring hole diameter 12 mm. Spindle with acme thread made completely of tempered steel, spindle head burnished.

Body and base element, tempered steel, burnished.



Focus Open 2020  
Gold



#### Recommendations



No. 6425Z,  
page 57



No. 6425MW,  
page 62

Order no.	TR	H min. [mm]	H max. [mm]	F max. [kN]	Weight [g]
562002	40 x 7	306	406	60	9436

#### Application:

Can be used on T-slots and grid plates by means of adapters, which are screwed in the base element. The individual elements are plugged together and connected by means of a threaded ring ensuring process reliability. The insertion tool makes it possible to use the locknut and base element as well as the thread adapter.

#### Advantage:

- Can be used modularly.

#### Note:

- The use as a head element in the screw jack modular makes a maximum height of 1626 mm with a permissible support force of 60 kN possible. In addition, there is a risk of buckling.  
- Do not adjust under load.

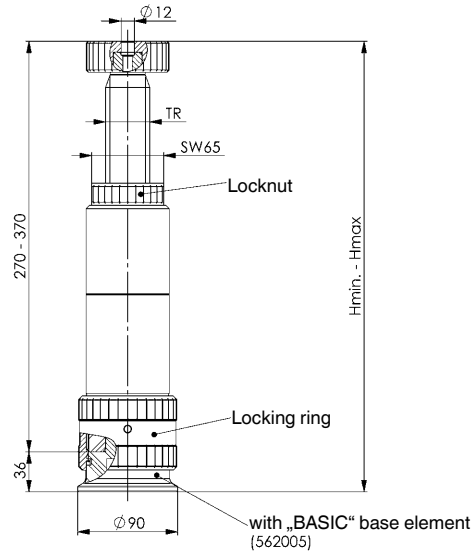

CAD



## No. 6425Z

### Spacer element

Tempered steel, burnished.



Order no.	Size	H	H1	Weight [g]
562003	100	100	150 - 166,5	3132
562155	200	200	250 - 266,5	6228
562004	300	300	350 - 366,5	7493

#### Application:

- As extension of the modular screw jack to achieve the maximum permitted support height of 1626 mm (with base element 6425FG or 6425FY).

#### Advantage:

- The maximum height of 1626 mm is continuously adjustable and a height overlap is attainable.  
- The connecting points are protected against soiling.  
- Improved handling by means of individual elements.  
- Set-up time saving thanks to flexibility of parts.  
- Storage optimisation.

#### Note:

- The use as an intermediate element in the screw jack modular makes a maximum height of 1626 mm with a permissible support force of 60 kN possible. In addition, there is a risk of buckling.  
- Do not adjust under load.

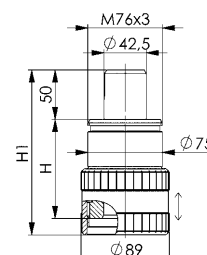

CAD



#### Recommendations



No. 6425FB,  
page 58



No. 6425S-406,  
page 57

Subject to technical alterations.

## No. 6425FB

### Base element

Tempered steel, burnished.



CAD

Order no.	D	H	Weight [g]
562005	90	36	1497

### Application:

Can be used on T-slots and grid plates by means of adapters, which are screwed in the base element. The individual elements are plugged together and connected by means of a threaded ring ensuring process reliability. The insertion tool makes it possible to use the base element as well as thread adapter.

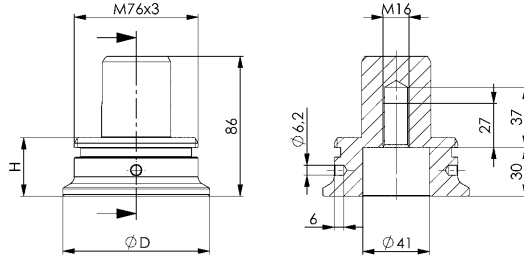

### Recommendations



No. 6425GA, page 58



No. 6425MW, page 62

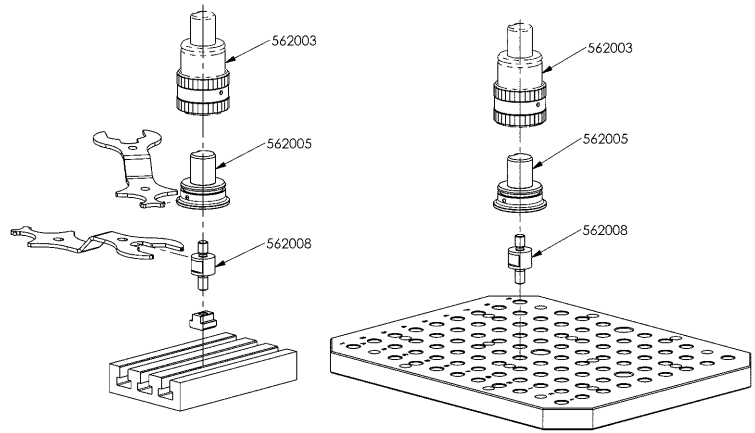

## No. 6425GA

### Thread adapter

Tempered steel, burnished.



CAD

Order no.	G	H	H1	H2	Weight [g]
562008	M16	83,5	25	29	339
562009	M20	91,5	25	37	381
562010	M24	101,5	25	47	452

### Application:

The thread adapters are screwed in the base element 6425FB and can thus be used on T-slots and grid plates. The insertion tool makes it easy to use the thread adapter.

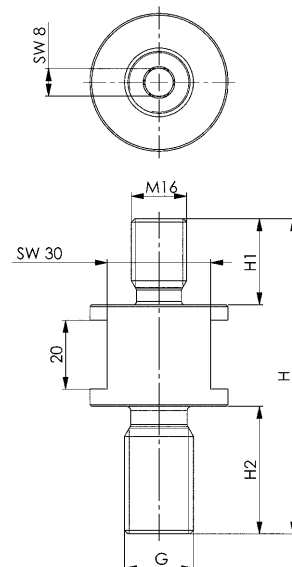

Subject to technical alterations.

## No. 6425FG

### Base element

Tempered steel, burnished.



CAD

Order no.	D	H	Weight [g]
562006	90	56	5717

### Application:

Can be used on T-slots and grid plates. The individual elements are plugged together and connected by means of a threaded ring ensuring process reliability. The insertion tool makes it possible to use the base element as well as thread adapter.

### Advantage:

- Enables variable positioning on the machine table.
- The threaded interface allows the base element to be replaced easily on the modular screw jack.

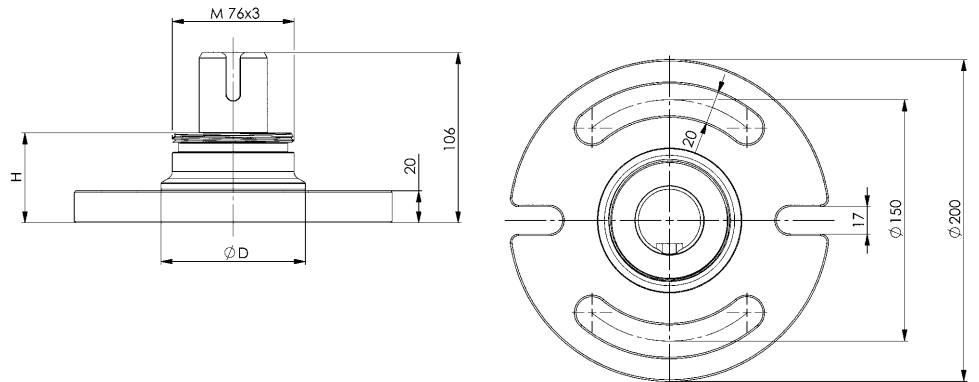

## No. 6425FY

### Base element

Tempered steel, burnished.



CAD

Order no.	D	H	Weight [g]
562007	90	56	5652

### Application:

Can be used on T-slots and grid plates. The individual elements are plugged together and connected by means of a threaded ring ensuring process reliability. The insertion tool makes it possible to use the base element as well as thread adapter.

### Advantage:

- Enables variable positioning on the machine table.
- The threaded interface allows the base element to be replaced easily on the modular screw jack.

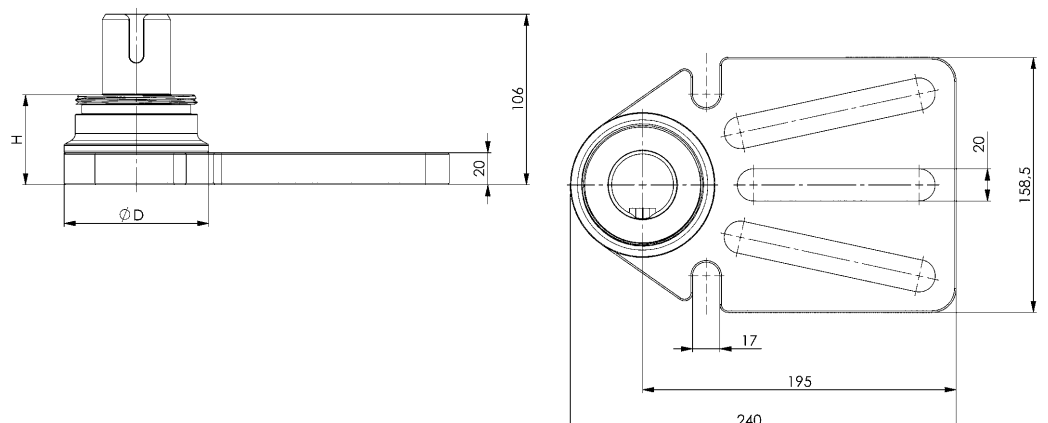

Subject to technical alterations.

## No. 6425A-230

### Height adjustment jack with fine thread and base element 6425FB

Body and base element, tempered steel, burnished.  
Spindle and bearing smooth, tempered steel, plasma-nitrided and burnished.



CAD

Order no.	H min. [mm]	H max. * [mm]	F max. [kN]	Weight [g]
562001	210	230	35	6671

\* maximum attainable height with an spacer element 6425Z-100 is 330 mm

#### Application:

Can be used on T-slots and grid plates by means of adapters, which are screwed into the base element. The bearings can be adjusted with an angle of  $\pm 3^\circ$ .

#### Advantage:

- The height adjustment jack can be adjusted up to a support height of max. 330 mm under load.
- Used as an extra support point to prevent sagging and vibration of the workpiece.
- Mounted directly under a clamping point, distortion of the workpiece is prevented.
- Compensation of large workpiece tolerances (castings and forgings).
- For use in horizontal and vertical clamping.

#### Note:

- maximum height 330 mm with the bearing with  $\pm 3^\circ$  angle function 6425AB, 6425AG, 6425AP
- maximum height 1626 mm with the fixed bearing without angle function 6425AGF
- The bearings are retained by magnets
- Bearings (smooth, spherical, point) can be replaced



Focus Open 2020  
Gold

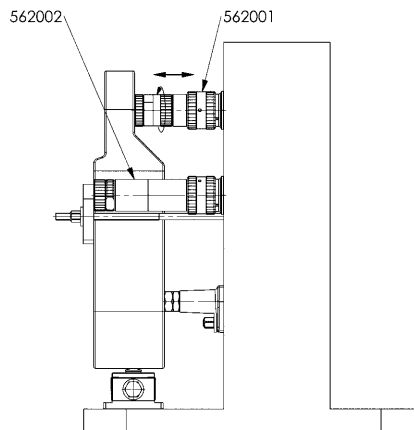
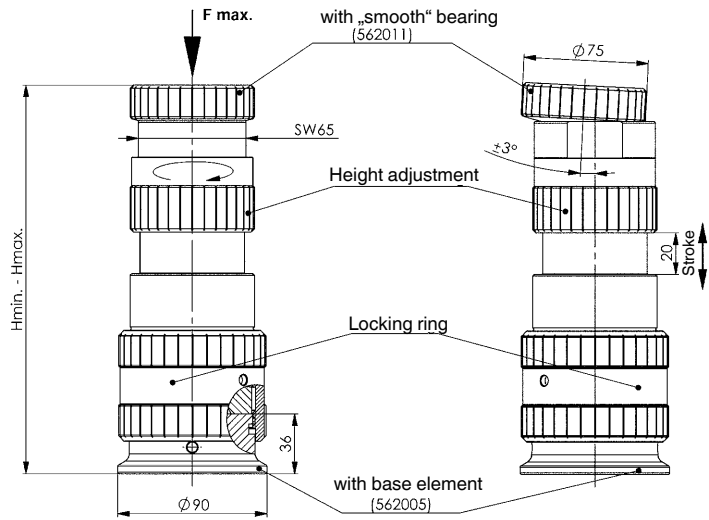

Subject to technical alterations.

## No. 6425AB

### Bearing, spherical

Tempered steel, plasma-nitrided and burnished.

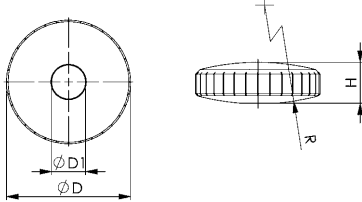

Order no.	dia. D [mm]	dia. D1 [mm]	H [mm]	R [mm]	Weight [g]
562012	75	20,5	24,7	140	655

#### Application:

- Interchangeable bearing for the support element 6425A-230.

#### Advantage:

- Compensation of large workpiece tolerances (castings and forgings).
- For use in horizontal and vertical clamping, since secured by magnet and cylinder pin.
- The bearings can be adjusted with an angle of  $\pm 3^\circ$ .

## No. 6425AG

### Bearing, smooth

Tempered steel, plasma-nitrided and burnished.



CAD

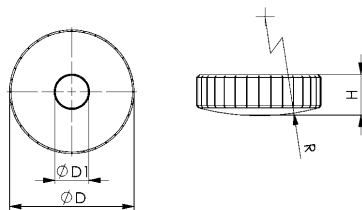

Order no.	dia. D [mm]	dia. D1 [mm]	H [mm]	R [mm]	Weight [g]
562011	75	20,5	24,7	140	739

#### Application:

- Interchangeable bearing for the support element 6425A-230.

#### Advantage:

- Compensation of large workpiece tolerances (castings and forgings).
- For use in horizontal and vertical clamping, since secured by magnet and cylinder pin.
- The bearings can be adjusted with an angle of  $\pm 3^\circ$ .

## No. 6425AP

### Bearing, point

Tempered steel, plasma-nitrided and burnished.

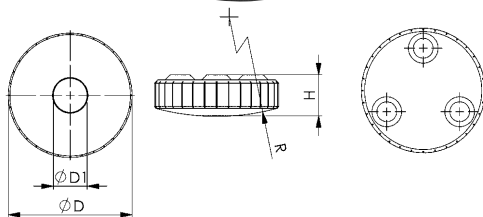

Order no.	dia. D [mm]	dia. D1 [mm]	H [mm]	R [mm]	Weight [g]
562013	75	20,5	24,7	140	651

#### Application:

- Interchangeable bearing for the support element 6425A-230.

#### Advantage:

- Compensation of large workpiece tolerances (castings and forgings).
- For use in horizontal and vertical clamping, since secured by magnet and cylinder pin.
- The bearings can be adjusted with an angle of  $\pm 3^\circ$ .

## No. 6425AGF

### Bearing, smooth, fixed

Tempered steel, plasma-nitrided and burnished.

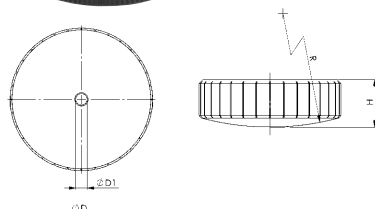

Order no.	dia. D [mm]	dia. D1 [mm]	H [mm]	R [mm]	Weight [g]
569434	75	6	25	140	750

#### Application:

- Interchangeable bearing for the support element 6425A-230

#### Advantage:

- Smooth, fixed support without angle function enables alignment with the support element and various spacer elements up to a total height of 1626 mm
- For use in horizontal and vertical clamping, since secured by magnet and cylinder pin.

Subject to technical alterations.

## No. 6425WW

### Tool cart

without screw jack elements  
 Steel housing powder-coated.  
 All surfaces protected with rubber mats.  
 2 rollers + 2 castors with locking brake

Order no.	Height x length	Weight [g]
	[mm]	
562015	1080 x 822	63240

### Advantage:

- mobile = quickly ready when needed at the workplace
- Tidy = convenient, space-saving and always readily available
- Individual equipment configurations possible through construction of many mounting points

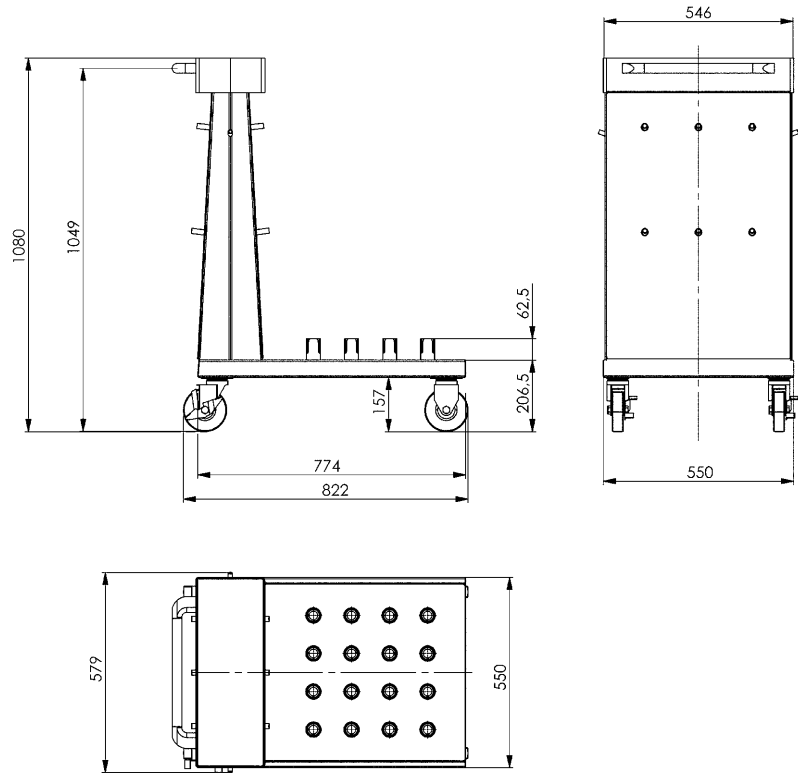

## No. 6425MW

### Insertion tool

Special steel, hardened and blued in black oxide finish.

Order no.	Size	D	SW1	SW2	Weight [g]
562014	76	6	65	30	960

### Application:

The insertion tool makes it possible to use the head and base elements of the screw jack modular as well as thread adapter.

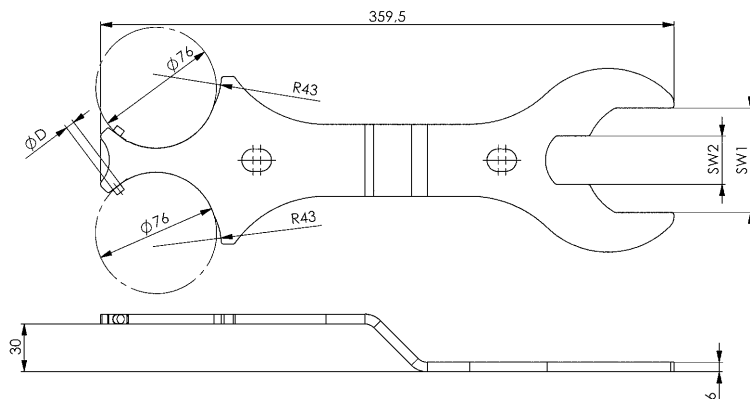

Subject to technical alterations.



Subject to technical alterations.

## No. 6400-285

### Screw jack set

- Tempered steel  
 Consisting of 1 item each  
 - Screw jack 6400 size 52  
 - Screw jack 6400 size 70  
 - Screw jack 6400 size 100  
 - Base element 6400FB  
 - Spacer element 6400Z-25  
 - Spacer element 6400Z-50  
 - Spacer element 6400Z-100  
 - Spherical attachment 6440G-M10  
 - Hook spanner DIN1810B

Order no.	Size	H min. [mm]	H max. [mm]	Weight [g]
569431	M10 x 12	42	285	4678
569432	M12 x 14	42	285	4691
569433	M16 x 18	42	285	4748

### Application:

The modular design allows the use of various screw jack intermediate and base elements, which are screwed together using the thread. The individual elements are fixed in place process safe using a hook spanner. A maximum height of 285 mm can be achieved with this set.

### Advantage:

- Maximum height of 422 mm achievable with additional intermediate elements
- Improved handling by means of individual elements
- Set-up time saving thanks to flexibility of parts
- storage optimisation

### Note:

Maximum achievable height of 422 mm with a permissible support force of 100 kN, above this there is a risk of buckling. Do not adjust under load.



### Recommendations



No. 6400Z,  
page 66



No. 6400FY,  
page 68

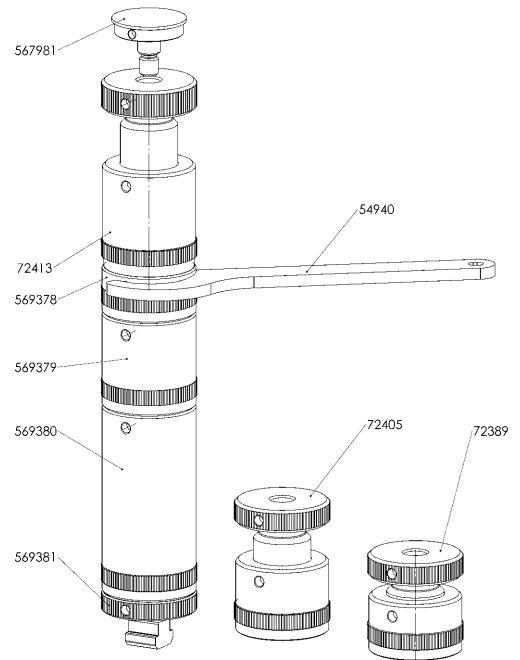
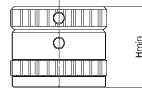
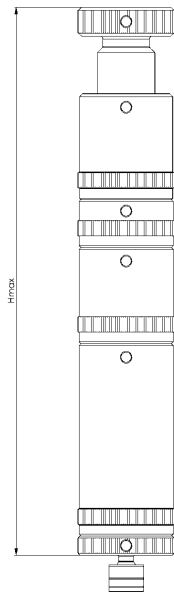

Subject to technical alterations.

## No. 6400

### Screw jack with flat support

Centring hole  $\varnothing 12$  mm / M10.

Spindle: self-locking acme thread, with final stop. Tempered steel, burnished.

Body: tempered steel, painted.

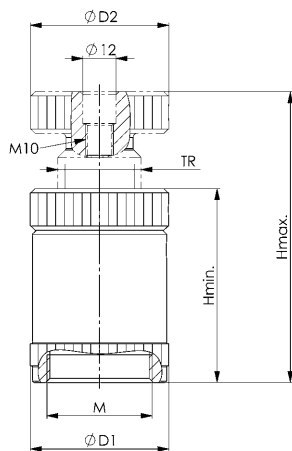

Order no.	Size	H min. [mm]	H max. [mm]	TR	D1	D2	M	F max. [kN]	Weight [g]
72397	50	38	50	20 x 4	31	31	-	25	190
72389	52	42	52	30 x 4	50	50	M38 x 2	100	550
72405	70	50	70	30 x 4	50	50	M38 x 2	100	620
72413	100	70	100	30 x 4	50	50	M38 x 2	100	900
72421	140	100	140	40 x 7	70	70	-	120	2760
72439	210	140	210	50 x 8	80	70	-	170	4600
72496	200	140	200	65 x 10	100	80	-	350	6900
72447	300	190	300	65 x 10	100	80	-	350	9000

### Application:

The sizes 52-100 are suitable for clamps with a slot width of approx. 14-22 mm. The screw jack no. 6430S represents a useful addition for large clamping heights. The sizes 140-300 are suitable for clamps with a slot width of approx. 20-40 mm. For these, the screw jacks no. 6435S represent a useful addition for large clamping heights. When using clamps DIN 6315B, 6315C and 6315GN from 26 mm slot width, we recommend, fixing cap no. 6443. The sizes 200-300 are intended for supporting large workpieces.

### Advantage:

- Modular design of sizes 52, 70, 100 with spacer elements 6400Z possible
- Improved rust protection, burnished spindle

### Note:

Size 50 without centring hole  $\varnothing 12$  / M10 mm. Size 200, 210 and 300 without thread M10. Suitable attachments for screw jack sizes 52-280 are nos. 6440, 6441, 6442, 6443 and 6445. The suitable support for sizes 52-100 is no. 6442 or 6442G. Do not adjust screw jack under load!

### Recommendations



No. 6440, page 80

No. 6441, page 80

## No. 6400M

### Screw jack with flat support and magnetic base

Centring hole  $\varnothing 12$  mm / M10. Spindle: self-locking acme thread, with final stop. Tempered steel, burnished.

Body: tempered steel, painted.

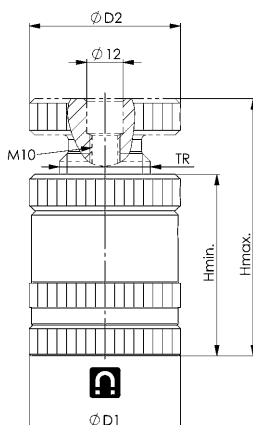

Order no.	Size	H min. [mm]	H max. [mm]	TR	D1	D2	F max. [kN]	Weight [g]
73320	62	52	62	30x4	50	50	100	700
73361	80	60	80	30x4	50	50	100	770
73403	110	80	110	30x4	50	50	100	1050

### Advantage:

- Improved rust protection, burnished spindle

### Note:

AMF screw jacks with magnetic base are designed for horizontal and vertical application. The permanent magnet allows permanent and exact positioning of the workpiece in a vertical position. The screw jacks are suitable for clamps of approx. 14-22 mm. When using clamps DIN 6415B, 6315C and 6315GN from 26 mm slot width, we recommend, by way of precaution, fixing cap no. 6443. Suitable attachments: No. 6440, 6441, 6442, 6443 and 6445. Suitable support for dismantled magnetic base: No. 6442G. Do not adjust screw jack under load!

### Recommendations



No. 6440, page 80

No. 6443, page 81

Subject to technical alterations.

No. 6400Z

## Spacer element

Painted tempered steel.



Order no.	Size	D1 [mm]	H [mm]	H1 [mm]	Weight [g]
569378	25	50	25	35	217
569379	50	50	50	60	593
569380	100	50	100	110	1320

### Application:

The spacer elements enable a modular height extension for the AMF 6400 screw jack in sizes 52/70/100. The individual elements are screwed together.

The combination of different base elements and the assembly of three screw jacks of different heights enables variable use.

The various elements can be fixed in place process safe using a hook spanner.

### Advantage:

- Maximum height of 422 mm is achieved continuously adjustable and with a height overlap
- Improved handling by means of individual elements
- Set-up time saving thanks to flexibility of parts
- storage optimisation

### Note:

Maximum achievable height of 422 mm with a permissible support force of 100 kN, above this there is a risk of buckling.

Do not adjust under load.

When using the magnetic base 6401M, a maximum height of 160 mm can be implemented when the modular screw jack is used horizontally.

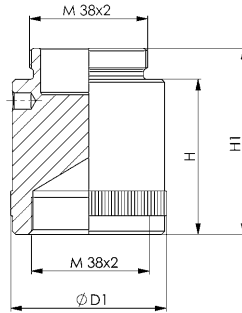

### Recommendations



No. 6400,  
page 65



No. 6400FY,  
page 68



DIN 1810B

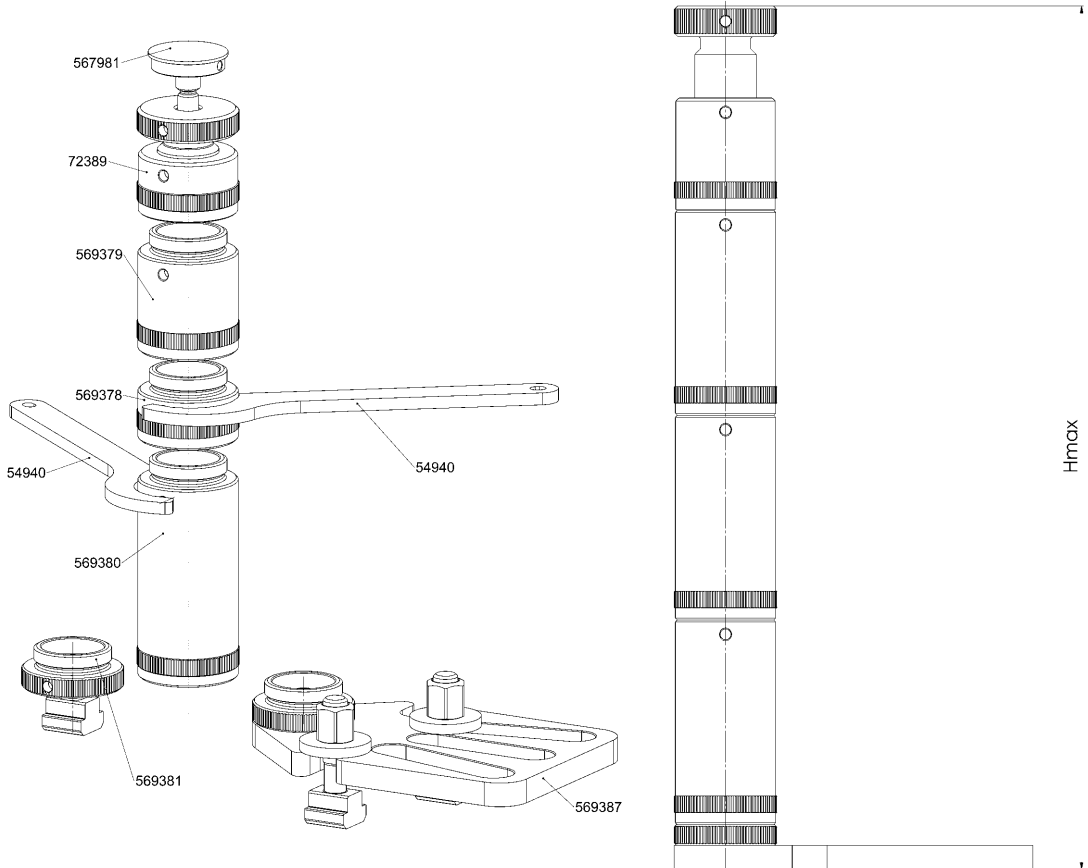

Subject to technical alterations.

## No. 6400FB

### Base element

Tempered steel, burnished.

Order no.	Size	A [mm]	G [mm]	H [mm]	Weight [g]
569381	M10 x 12	12	M10	10	212
569382	M12 x 14	14	M12	10	230
569386	M16 x 18	18	M16	10	287

### Application:

The base elements can be used on T-slots and grid plates.

Screw jack elements in sizes 52/70/100 can be screwed directly onto the base elements or spacer elements.

### Advantage:

By using the 6400FB base elements, the 6400 modular screw jack can be bolted process safe horizontally and vertically. For this purpose, the base element can be fastened in T-slots using the nut for T-slots supplied. It is also possible to screw directly onto breadboard plates or fixture plates.

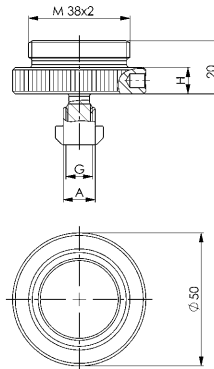

### Recommendations



No. 6400,  
page 65



No. 6400Z,  
page 66



DIN 1810B

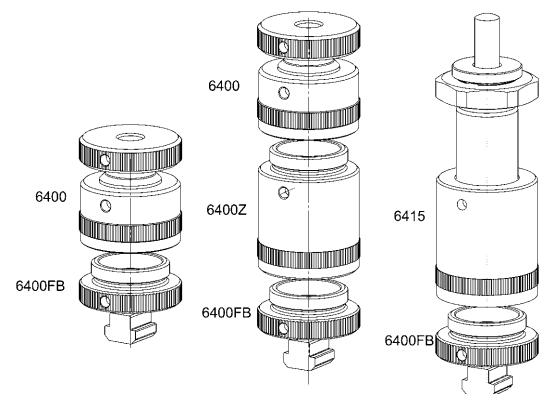

## No. 6400FY

### Base element slot

Tempered steel, burnished.

Order no.	H [mm]	Weight [g]
569387	22	1280

#### Application:

The base elements can be used on T-slots and grid plates. Screw jack elements in sizes 52/70/100 can be mounted directly onto the base elements or spacer elements.

#### Advantage:

- Enables variable positioning on the machine table.
- The threaded interface allows the base element to be replaced easily on the modular screw jack.

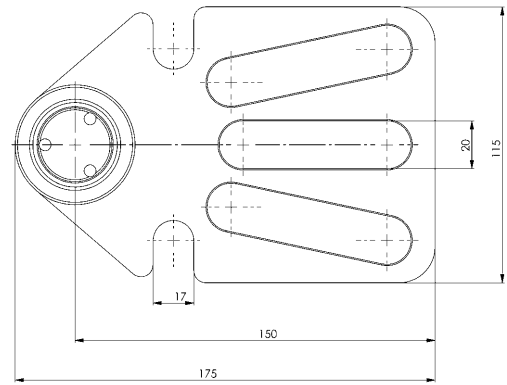

#### Recommendations



No. 6400,  
page 65



No. 6400Z,  
page 66



DIN 1810B

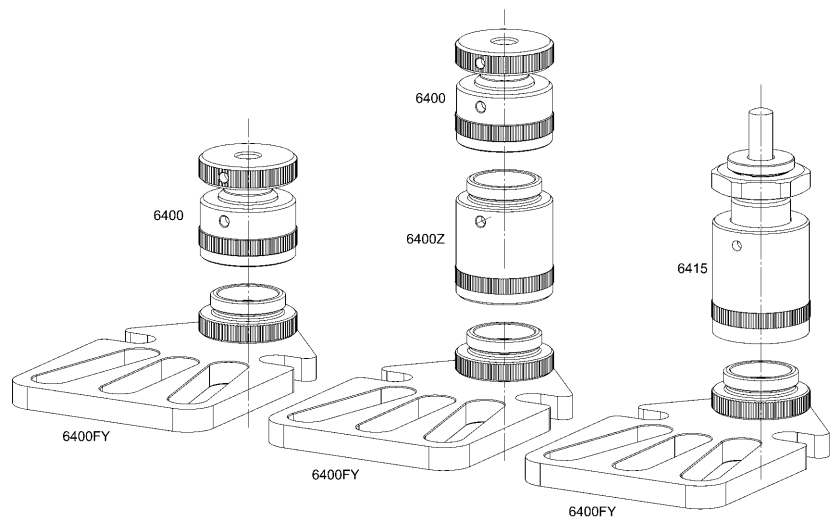

Subject to technical alterations.

## No. 6401

### Aluminium screw jack

Centring hole  $\varnothing 12$  mm / M10. Spindle: tempered steel burnished, self-locking trapezoidal thread, with final stop. Base: aluminium 400 N/ mm<sup>2</sup> tensile strength.



Order no.	Size	H min. [mm]	H max. [mm]	TR	D1	D2	M	F max. [kN]	Weight [g]
75770	52	42	52	30x4	50	50	M38 x 2	30 *	370
75788	70	50	70	30x4	50	50	M38 x 2	30 *	430
75796	100	70	100	30x4	50	50	M38 x 2	30 *	600

#### Application:

Protects the tables from precision machines (steel chips do not penetrate into the machine table, but into the aluminium base). Suitable for all machine tool tables as well as for guide and measuring plates with precision machined surfaces.

#### Advantage:

Modular design with aluminium spacer elements 6401Z possible.

#### Note:

F max.\* until max. 350 mm total height ensured. In addition, there is a risk of buckling. Suitable attachments: no. 6440, 6440G, 6441, 6442, 6442G/M10, 6443/14 and 6445. Suitable support: no. 6401MF, 6401AF, 6400FB, 6400FY. Do not adjust screw jack under load!

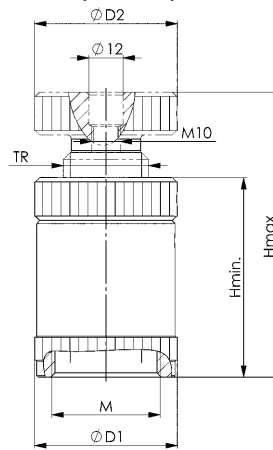

#### Recommendations



No. 6401Z, page 71

## No. 6401M

### Aluminium screw jack with magnetic base

Centring hole  $\varnothing 12$  mm / M10. Spindle: tempered steel burnished, self-locking trapezoidal thread, with final stop. Base: aluminium 400 N/ mm<sup>2</sup> tensile strength.



Order no.	Size	H min. [mm]	H max. [mm]	TR	D1	D2	F max. [kN]	Weight [g]
75804	62	52	62	30x4	50	50	30 *	380
75812	80	60	80	30x4	50	50	30 *	550
75820	110	80	110	30x4	50	50	30 *	710

#### Application:

AMF screw jacks with magnetic base are designed for horizontal and vertical application. The permanent magnet allows permanent and exact positioning of the workpiece in a vertical position.

#### Advantage:

Modular design with aluminium spacer elements 6401Z possible.

#### Note:

F max.\* until max. 350 mm total height ensured. In addition, there is a risk of buckling. Suitable attachments: no. 6440, 6440G, 6441, 6442, 6442G/M10, 6443/14 and 6445. Suitable support: no. 6401MF, 6401AF, 6400FB, 6400FY. Do not adjust screw jack under load!

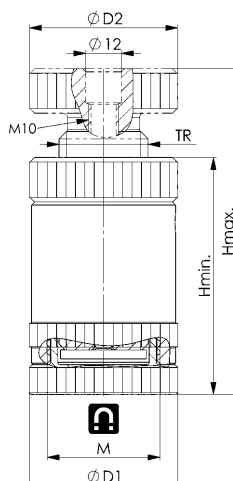

Subject to technical alterations.

## No. 6406A-88

### Aluminium screw jack with chip guard plate and aluminium base

Screw jack thread protected penetration of chips by the scraper.  
Centring hole  $\varnothing 12$  mm / M10.

Spindle: tempered steel burnished, self-locking trapezoidal thread, with final stop.

Base: aluminium 400 N/mm<sup>2</sup> tensile strength.



Order no.	Size	H min. [mm]	H max. [mm]	TR	D1	D2	F max. [kN]	Weight [g]
72850	88	75	88	30x4	50	50	30	630

#### Application:

AMF screw jacks with aluminium base are designed for vertical applications.

#### Advantage:

The screw jack thread is protected from the penetration of chips by the scraper. Modular design with aluminium spacer elements 6401Z possible.

#### Note:

F max. until max. 350 mm total height ensured. In addition, there is a risk of buckling.

Suitable attachments: no. 6440, 6440G, 6441, 6442, 6442G/M10, 6443/14 and 6445

Suitable support: no. 6400FB, 6400FY

Do not adjust screw jack under load!

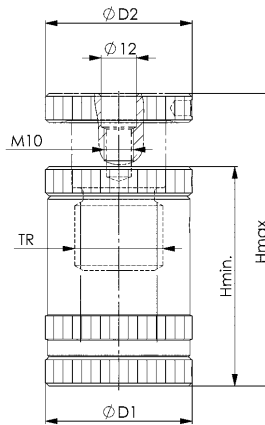

#### Recommendations



No. 6401Z, page 71



No. 6440G, page 80

## No. 6406M-88

### Aluminium screw jack with chip guard plate and magnetic base

Screw jack thread protected penetration of chips by the scraper.  
Centring hole  $\varnothing 12$  mm / M10.

Spindle: tempered steel burnished, self-locking trapezoidal thread, with final stop.

Base: aluminium 400 N/mm<sup>2</sup> tensile strength.



Order no.	Size	H min. [mm]	H max. [mm]	TR	D1	D2	F max. [kN]	Weight [g]
72868	88	75	88	30x4	50	50	30	720

#### Application:

AMF screw jacks with magnetic base are designed for horizontal and vertical application. The permanent magnet allows permanent and exact positioning of the workpiece in a vertical position.

#### Advantage:

The screw jack thread is protected from the penetration of chips by the scraper. Modular design with aluminium spacer elements 6401Z possible.

#### Note:

F max. until max. 350 mm total height ensured. In addition, there is a risk of buckling.

Suitable attachments: no. 6440, 6440G, 6441, 6442, 6442G/M10, 6443/14 and 6445

Suitable support: no. 6400FB, 6400FY

Do not adjust screw jack under load!

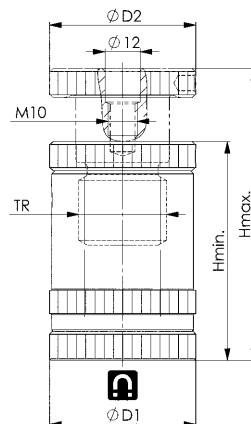

#### Recommendations



No. 6401Z, page 71



No. 6440G, page 80

## No. 6401Z

### Aluminium spacer element

for the height extension of aluminium screw jacks.

Order no.	Size	H	D1	M	F max. [kN]	Weight [g]
72876	12	12,5	50	M38 x 2	30	38
72884	25	25,0	50	M38 x 2	30	76
72926	50	50,0	50	M38 x 2	30	165

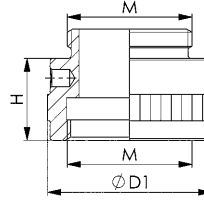

## No. 6401MF

### Magnetic base for screw jacks

Housing: Steel, black zinc-plated

Order no.	H	D1	M	Weight [g]
558436	10	50	M38 x 2	125

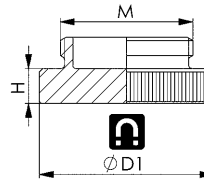

## No. 6401AF

### Aluminium base for screw jacks

Case: Aluminium

Order no.	H	D1	M	F max. [kN]	Weight [g]
557186	10	50	M38 x 2	30	60

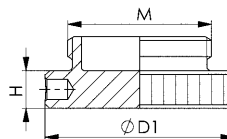

### Recommendations



No. 6401Z,  
page 71

Subject to technical alterations.

No. 6406-125

## Aluminium screw jack with swarf protection

Screw jack thread protected penetration of chips by the scraper. Centring hole  $\varnothing 12$  mm / M10. Spindle: tempered steel burnished, self-locking trapezoidal thread, with final stop.

Consisting of:

- Screw jack with chip guard
- Spacer element 12.5 mm
- Spacer element 25 mm
- Aluminium and magnetic base.

Order no.	Size	H min. [mm]	H max. [mm]	TR	D1	D2	F max. [kN]	Weight [g]
72371	125	75	125	30x4	50	50	30*	920

### Application:

AMF screw jacks with magnetic base are designed for horizontal and vertical application. The permanent magnet allows permanent and exact positioning of the workpiece in a vertical position.

### Advantage:

The screw jack thread is protected from the penetration of chips by the scraper. Modular design with aluminium spacer elements 6401Z possible.

### Note:

F max. until max. 350 mm total height ensured. In addition, there is a risk of buckling.

Suitable attachments: no. 6440, 6440G, 6441, 6442, 6442G/M10, 6443/14 and 6445

Suitable support: no. 6400FB, 6400FY

Do not adjust screw jack under load!

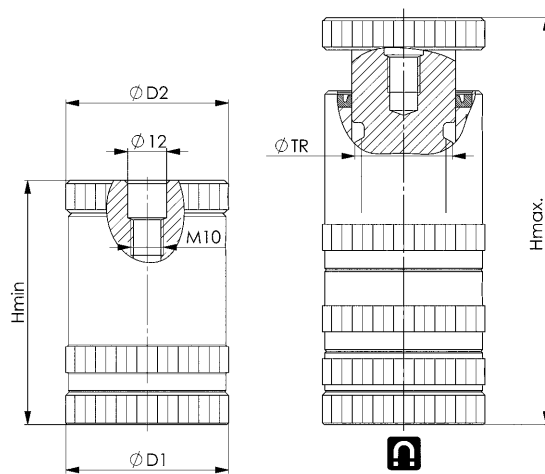

### Recommendations



No. 6401Z,  
page 71



No. 6440G,  
page 80

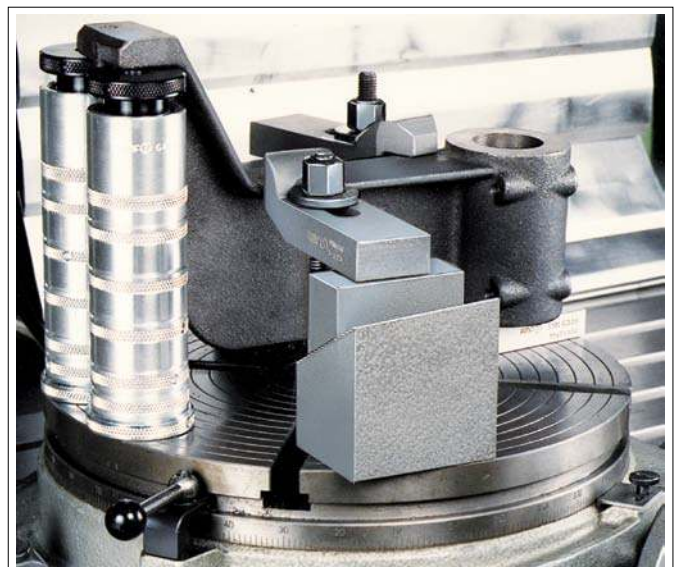

Subject to technical alterations.

CAD





## No. 6415

### Height setting screw jack

with a cylinder pin ISO8734-12x50. Centring hole  $\varnothing 12$  mm. Spindle: Metric fine thread M30x1.5 with final stop. Sliding insert runs on pressed plain bearing bushing. Tempered steel, burnished.



Order no.	Size	H min. [mm]	H max. [mm]	D1	D2	H1 min.	H1 max.	F max. [kN]	Weight [g]
86504	75	55	75	50	34	82	102	30	680
86512	115	75	115	50	34	102	142	30	950

#### Application:

The height guide bench vice can also be used without cylinder pin or with the attachments No. 6440 and No. 6441. The combination with all AMF screw jacks is possible with centring plate.

#### Advantage:

Sensitive adjustment. A bearing insert prevents the workpiece from being turned while the jack is adjusted.

#### Note:

Suitable attachments: No. 6440, 6441 and 6442.  
Suitable support: No. 6442G.

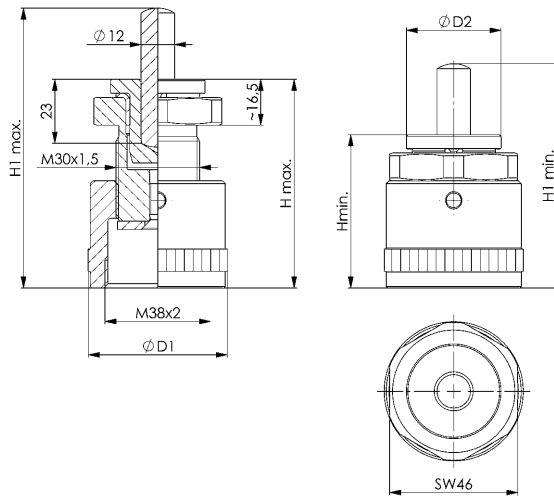

#### Recommendations



No. 6440, page 80



No. 6441, page 80



No. 6442, page 81

CAD



## No. 6416

### Height setting screw jack with magnetic base

with a cylinder pin ISO8737-12x50. Centring hole  $\varnothing 12$  mm. Spindle: Metric fine thread M30x1.5 with final stop. Sliding insert runs on pressed plain bearing bushing. Tempered steel, burnished.



Order no.	Size	H min. [mm]	H max. [mm]	D1	D2	H1 min.	H1 max.	F max. [kN]	Weight [g]
86520	85	65	85	50	34	92	112	30	800
86538	125	85	125	50	34	112	152	30	1000

#### Application:

The height guide bench vice can also be used without cylinder pin or with the attachments No. 6440 and No. 6441. The combination with all AMF screw jacks is possible with centring plate.

#### Advantage:

Sensitive adjustment. A bearing insert prevents the workpiece from being turned while the jack is adjusted.

#### Note:

Suitable attachments: No. 6440, 6441 and 6442.  
Suitable support for dismantled magnetic base: No. 6442G.

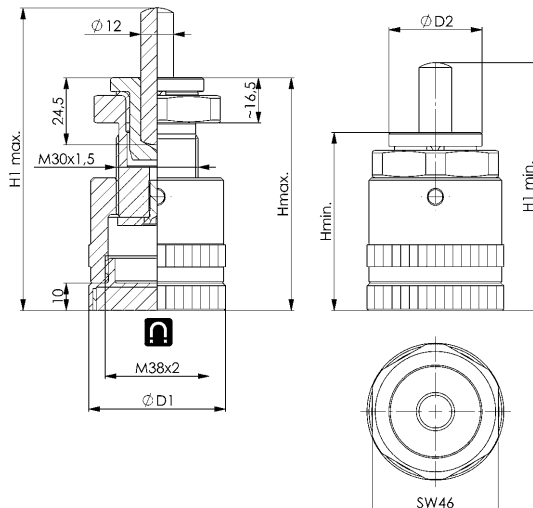

#### Recommendations



No. 6315GN, page 32



No. 6315GNG, page 32

CAD



Subject to technical alterations.

## No. 6420

### Height setting screw jack with pivotable ball

Steel tempered, burnished. Ball made of hardened steel.



Order no.	Size	H min. [mm]	H max. [mm]	F max. [kN]	Weight [g]
72546	70	56	70	30	950

#### Application:

This element with its pivotal support is particularly useful in the support and alignment of free-form surfaces e.g. of workpieces which are made of cast iron and forging-grade steels. The precision of alignment is approx. 0.1 mm.

#### Advantage:

- The pivotable ball minimizes the friction on the support and reduces the required operating forces.
- The use of a point-like support prevents the transmission of the torsional force created by the movement of the spindle. The position of the workpiece remains unchanged.
- The simple and rugged construction provides for a long lasting service life.

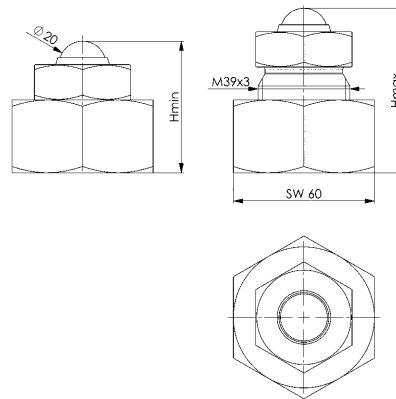

#### Recommendations



No. 6400,  
page 65



No. 6415,  
page 74



## No. 6460

### Wedge block „Herkules“ height wedge

Ø12 mm centring hole. Ductile iron and steel, tempered, quenched in black oxide finish. Wedge surface finely machined. A spherical attachment 6440 or 6440G accompanies each wedge block.



Order no.	Size	H min. [mm]	H max. [mm]	B1 [mm]	B1 [mm]	H1 [mm]	H1 [mm]	L [mm]	SW [mm]	H/U* [mm]	F max. [kN]	Weight [g]
72777	63	50	68	63	40	80	7	63	13	0,9	40	1700
72785	125	100	125	115	60	135	20	125	24	1,2	100	8600
72793	190	170	190	145	80	200	20	175	36	2,0	250	23750

\*H/U= height adjustment per single turn.

### Application:

The fine-machined wedge surfaces permits a smooth, precise adjustment to less than 1/10 mm. The double wedge effect produces a large stroke and precise vertical movement with no lateral shift. The height wedge proves its worth with heavy castings or forgings on large tool machines. The AMF „Herkules“ whipstock has an additional centring hole in the floor of the base area.

### Advantage:

For the sizes 125 and 190, the attachment 6440G can be screwed in so it cannot be lost.

### Note:

Suitable attachments for wedge block No. 6460 are No. 6440, 6440G, 6441 and 6442. All sizes with lateral clamping rim for fastening on the machine table. For size 63, the base plate is removable for reaching Hmin.

72777

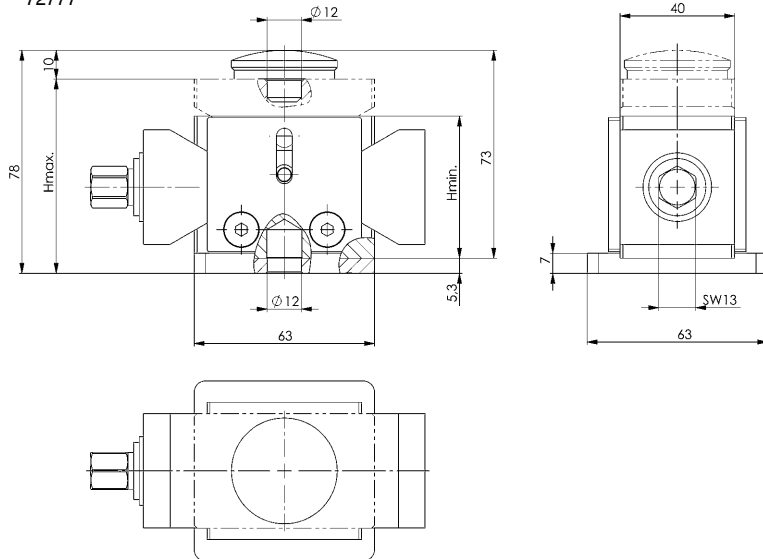

72785 / 72793

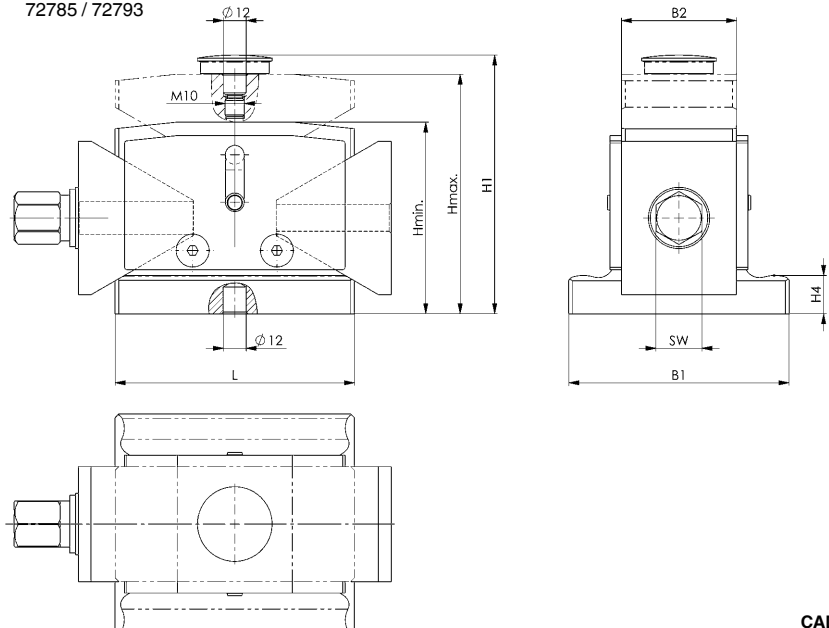

### Recommendations



No. 6440,  
page 80



No. 6440G,  
page 80



No. 6444,  
page 81



Subject to technical alterations.

## No. 6465

### Precision wedge block

Centring hole  $\varnothing$  12 mm. Case-hardened steel and fine-machined wedge surfaces. A spherical attachment no. 6440 is included with every precision whipstock.



Order no.	Size	H min. [mm]	H max. [mm]	H/U* [mm]	F max. [kN]	SW [mm]	Weight [Kg]
<b>375592</b>	<b>55</b>	50	55	0,71	40	22	2,8
<b>375618</b>	<b>85</b>	77	85	0,71	250	36	11,5

\*H/U= height adjustment per single turn.

### Application:

- The fine-machined wedge surfaces permits a smooth, precise adjustment to less than 1/10 mm.
- Operation can be via an open-ended spanner - hence ensuring enhanced safety and ease of handling due to the large adjusting forces.
- The double wedge effect produces a precise vertical movement with no lateral slide.
- The flat design of the precision height wedge enables higher safety properties to be realised when aligning heavy and large components.
- The precision whipstock has an additional centring hole in the floor of the base surface for alignment on the machine table.

### Advantage:

Precision whipstock can be adjusted under load.

### Note:

- Suitable caps for the precision whipstock are nos. 6440, 6441 and 6442
- Height adjustment is 0.71 mm / revolution

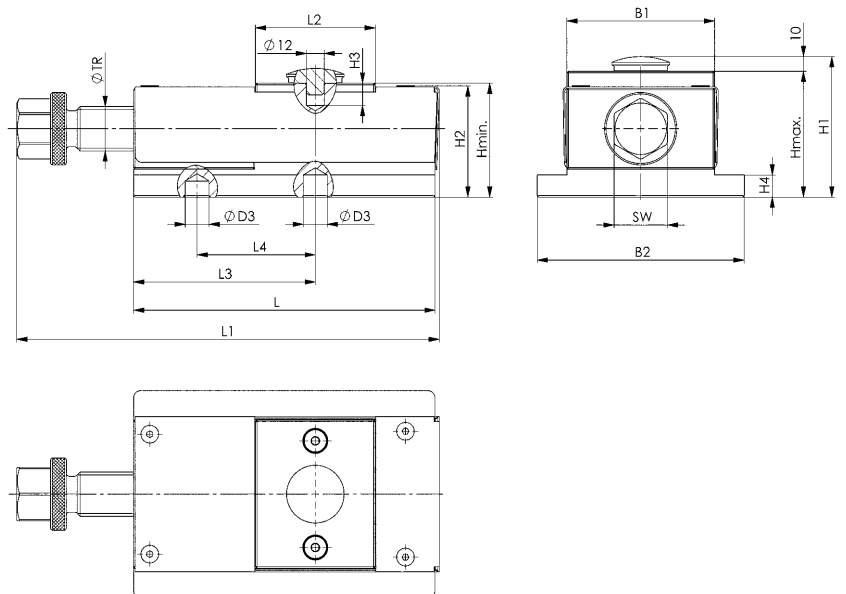

### Recommendations



No. 6440,  
page 80



No. 6445,  
page 81



No. 6443,  
page 81

### Dimensions:

Order no.	B1	B2	TR	H1	H2	H3	H4	L	L1	L2	L3	L4	D3
<b>375592</b>	60	80	20	60-65	47,5	10	13	128	150-179	60	71	-	12
<b>375618</b>	100	140	30	87-95	74,0	15	15	204	242-287	81	123	80	16

CAD



Subject to technical alterations.

## No. 6430S

### Atlas screw jack with counter nut

Centring hole dia. 12 mm. Spindle complete: tempering steel with trapezoidal thread. Spindle head blued. Housing: cast iron, varnished.



Order no.	Size	H min. [mm]	H max. [mm]	TR	B1	B2	L	SW	F max. [kN]	Weight [Kg]
72553	140	100	140	30x6	18	75	110	46	60	1,8
72561	200	140	200	30x6	18	75	110	46	60	2,2
72579	320	200	320	30x6	22	90	160	46	40	3,8
72587	550	320	550	30x6	22	90	160	46	25	4,9

#### Note:

When using clamps DIN 6315B, 6315C and no. 6315GN with slot-sizes above 26 mm we recommend the use of locating pad no. 6443 for safety. Suitable pads are no. 6440, 6441, 6442, 6443 and 6445. Do not adjust screw jack under load!

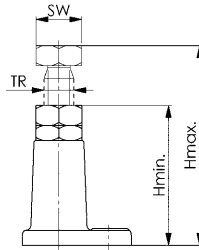

6430S-140  
6430S-200

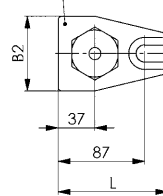

6430S-320  
6430S-550

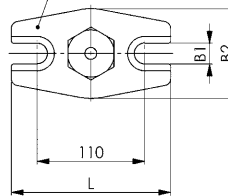

#### Recommendations



No. 6442,  
page 81



No. 6443,  
page 81



No. 6445,  
page 81

CAD



## No. 6435S

### Heavy screw jack

with nickel lock bolt. Centring hole D12 / M10. Spindle: Tempered steel, self-locking acme thread, with final stop. Spindle head burnished. Body: tempered steel, painted.



Order no.	Size	H min. [mm]	H max. [mm]	TR	B1	B2	L	SW	F max. [kN]	Weight [Kg]
72637	300	200	300	40x7	26	190	220	65	80	8
72645	460	290	470	40x7	26	190	220	65	60	10
72652	750	430	750	40x7	26	190	220	65	50	13
72660	1250	710	1250	40x7	26	190	220	65	40	18

#### Advantage:

- Thread M10 on the spindle top for fixing attachment elements.
- Greater clamping heights can be achieved by installing with no. 6442G and no. 6415.
- Base plate with closed slots for fastening onto the machine table. Accordingly, it can also be used for rotating clamping tasks.

#### Note:

When using clamps DIN 6315B, 6315C and No. 6315GN from 26 mm slot width, we recommend the fixing cap No. 6443. Suitable attachments for screw jack No. 6435S are No. 6440, 6441, 6442, 6443, 6445 and 6442G.

Do not adjust screw jack under load!

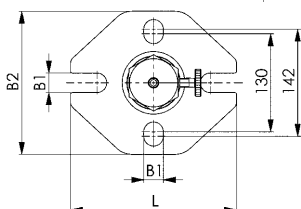
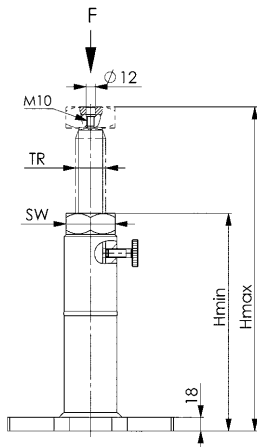

#### Recommendations



No. 6440,  
page 80



No. 6441,  
page 80



No. 6445,  
page 81

CAD



Subject to technical alterations.

## No. 6438S

### Screw jack, quick-action

continuously adjustable with nickel lock bolt.  
 Centring hole D12 / M10. Spindle: Tempered steel, self-locking  
 acme thread with final stop.  
 Spindle head burnished. Body: tempered steel, painted.



Order no.	Size	H min. [mm]	H max. [mm]	TR	B1	B2	D	L	SW	F max. [kN]	Weight [Kg]
75705	450	320	450	40x7	26	190	90	220	65	50	11,5
75713	710	450	710	40x7	26	190	90	220	65	40	13,7
75721	1250	710	1250	40x7	26	190	90	220	65	30	18,3

### Application:

This screw jack allows fast adjustment and continuous adjustment within the entire height range.  
 Suitable attachments: No. 6440, 6441, 6443, 6445 and 6442G.

### Advantage:

- Thread M10 on the spindle top for fixing attachment elements.
- Greater clamping heights can be achieved by installing with No. 6442G and No. 6415.
- Base plate with closed slots for fastening on the machine table.

### Note:

- Hold spindle, max. 6 kg
  - Undo lock bolt
  - Turn actuating ring to undo the spindle
  - Adjust height
  - Turn actuating ring to fasten the spindle
  - Secure spindle with lock bolt
- Do not subject the screw jack to excessive load!

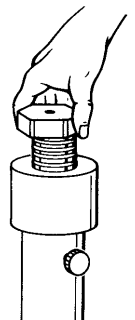
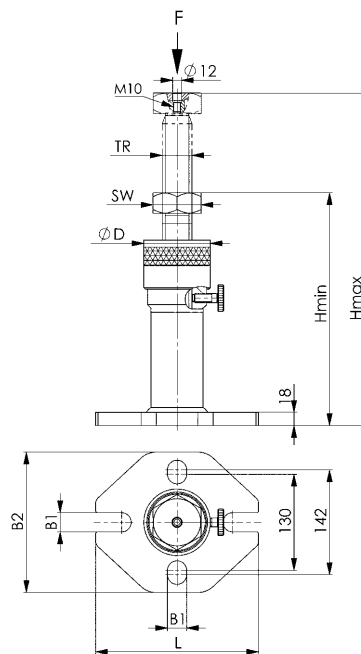

### Recommendations



No. 6440,  
page 80



No. 6441,  
page 80



No. 6442,  
page 81

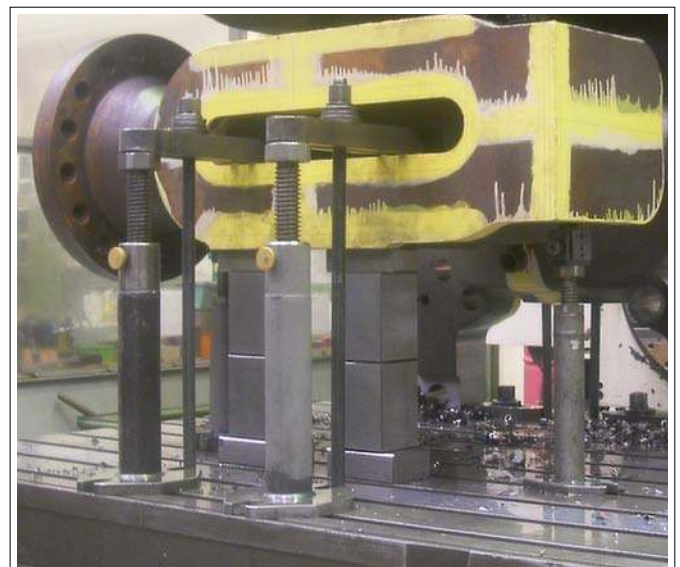

Subject to technical alterations.

## No. 6440

### Ball-pad

Steel tempered, burnished.

Order no.	H	D	Weight [g]
72710	10	39	75

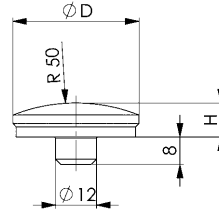

## No. 6440G

### Spherical attachment with thread

Tempered steel, burnished quenched.

Order no.	H	D1	D2	G1	H1	H2	Weight [g]
567981	10	39	11,9	M10	32	22	95

#### Application:

The centring plate can be screwed to the screw jacks 6435S, 6438S or onto the wedge block 6460 size 125/190.

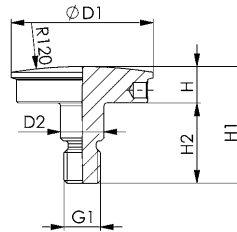

## No. 6440GS

### Swivelling attachment smooth with +/- 3° angle function

Tempered steel, burnished quenched.

Order no.	Size	H	D	Weight [g]
570303	M10	27,5	50	389

#### Application:

The swivel attachment can be fastened to the spindle heads of the AMF 6400, 6435S or 6438S screw jacks using a thread.

#### Features:

The support has a +/- 3° angle function and allows the compensation of large workpiece tolerances.

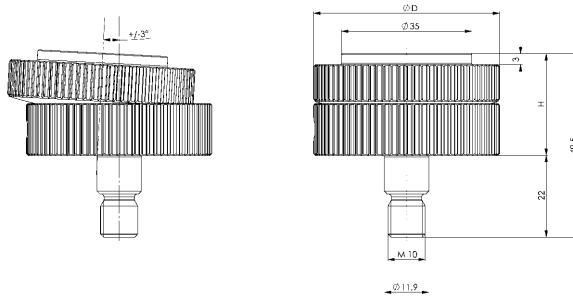

#### Recommendations



No. 6400, page 65



No. 6435S, page 78

## No. 6441

### Vee-pad

Steel tempered, burnished.

Order no.	Size	H	D	D1 min.	D1 max.	Weight [g]
72728	45	15	45	10	50	120
72769	65	30	65	22	100	545

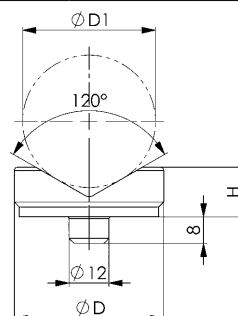

Subject to technical alterations.

## No. 6442

### Centering-pad

Steel tempered, burnished.



Order no.	H	D	D1	Weight [g]
72736	8	45	35,8	120

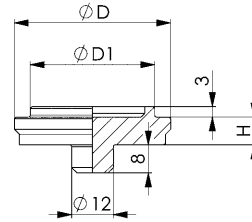

## No. 6443

### Locating-pad

for forked clamps. Steel tempered, burnished.



Order no.	Size	H	D	D1	L	Weight [g]
72751	14	12	63	14	15	310
72744	25	15	78	25	25	650

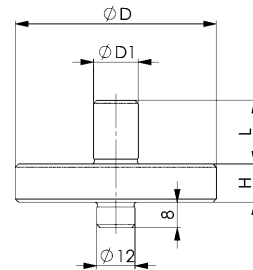

## No. 6444

### Locating-pad

with cylindrical face. Steel tempered and burnished.



Order no.	H	B	L	Weight [g]
72454	23	50	19	370

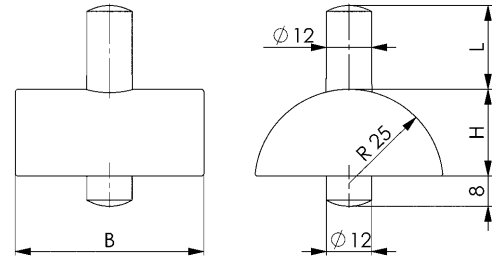

## No. 6445

### Support with pivotable ball

Steel tempered, burnished. Ball made of hardened steel.



Order no.	H	D	F max. [kN]	Weight [g]
72819	25	45	30	240

### Application:

This rugged element was designed for the supporting and alignment of workpieces made of cast iron and forging-grade steels. Designed for use with AMF-screw jacks.

### Advantage:

- The pivotable ball minimizes the friction on the support and reduces the required operating forces.
- The use of a point-like support prevents the transmission of the torsional force created by the movement of the spindle. The position of the workpiece remains unchanged.
- The simple and rugged construction provides for a long lasting service life.

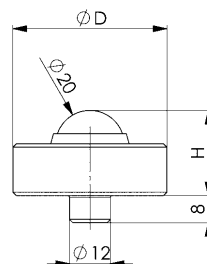

Subject to technical alterations.

## No. 6442G

### Centring plate with thread

Steel tempered, burnished.



Order no.	Size	D1	D2	H	H1	H2	M	Weight [g]
562125	M10	50	11,9	10	41	22	M38x2	200

#### Application:

Centring plate can be screwed onto screw jacks. The screw jacks can be screwed onto the centring plate.

- Height guide bench 6415
- Screw jack with flat bearing 6400-52 /-70/-100
- Aluminium-screw jack 6401

#### Note:

The maximum possible support force of the screw jack combination must be adjusted to the support force ( $F_{max.}$ ) of the screw jack used.

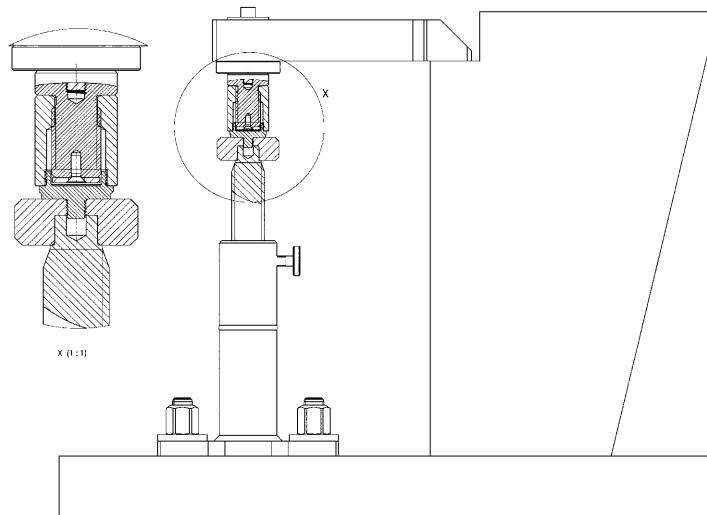
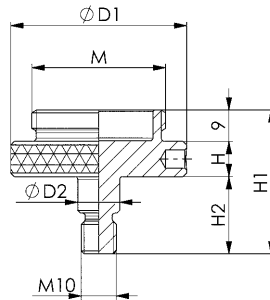

CAD

## No. 6418

### Support element, mechanical

incl. DIN 508-M12x14 nut for T-grooves, M12x30-10.9 threaded stud. Body: Case-hardened steel, manganese phosphatised and ground. Body: Aluminium.



Order no.	Size	Support force F max. [kN]	H	Stroke [mm]	SW1	SW2	G	Weight [g]
75416	M12	8	78-83	5	21	6	M12	939

### Application:

1. Fasten support element (2x M6 connecting thread) on fixture.  
- Note operator side!
- Alternatively: Remove M12 x 10 threaded stud and replace with M12 x 30 threaded stud and mount the support element with key (size 21), e.g. for T-groove mounting  
- (No defined operator side ensured).
2. Turning the clamping cam (hexagon socket size 6) on the outside surface of the red protective sleeve positions the supporting bolt against the workpiece with light spring force.
3. Turning further as far as it will go (lock) - a total of 180° - locks the clamping mechanism of the supporting bolt without length change.  
The support element is positioned on the workpiece and locked.
4. Turning in the opposite direction (unlock) releases the clamping. Continuing to turn back as far as it will go - a total of 180° - moves the supporting bolt to the end position.

### Advantage:

- Used as an extra support to prevent sagging and vibration of the workpiece.
- Mounted directly under a clamping point, it prevents distortion of the workpiece.
- Compensation of large workpiece tolerances (castings).

### Note:

- M8 thread on supporting bolt can be mounted with pressure screws (Nos. 7110DHX, 7110DIX, 7110DKX, 7110DFX).
- Customer-specific extensions can also be mounted.
- For reliable function the M12 threaded hole must always be closed.

### Dimensions:

Order no.	Size	D	D1	H1	H2	H3	H4
75416	M12	55	49,4	10	16	25	10,5

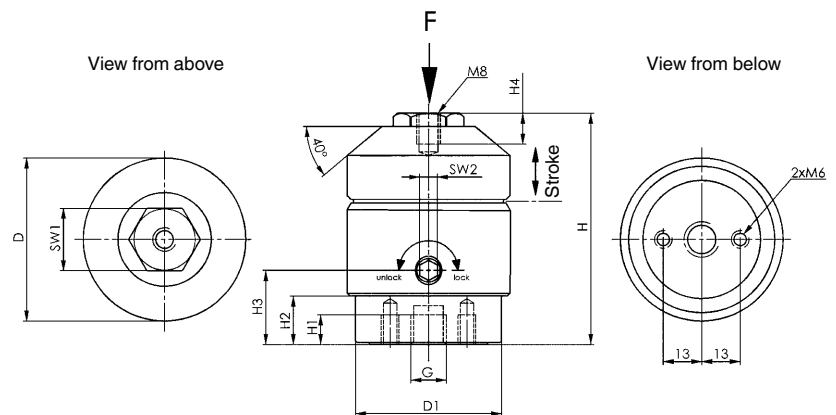

### Application example:

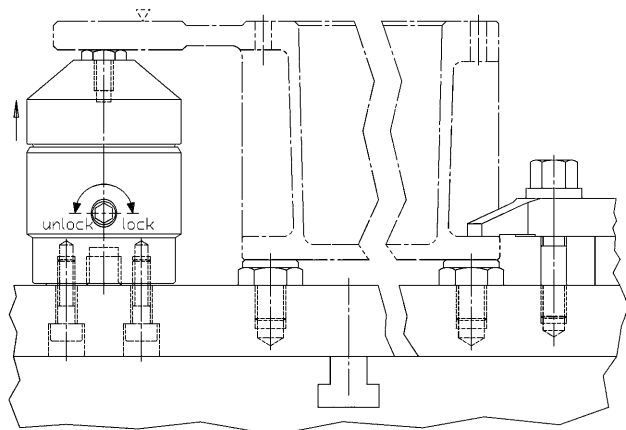

**No. 6417**
**Mandrel**

blued, with brass thrust piece.

Order no.	Size	Slot	H ±0,1	H1 min.	H1 max.	H2 min.	H2 max.	dia. D1	dia. D2	dia. D3	G1	G2	SW	Weight [g]
74179	80	14	80	116	148	8	40	40	50	32	M12	M16	27	1270
568987	80L	14	80	148	180	40	72	40	50	32	M12	M16	27	1310

**Application:**

- The mandrels are fastened to the machine table by means of T-nuts.
- The mandrel is fixed on the slotted table by operating the SW 27 mm pre-tensioning nut.
- Clamping is by means of the SW 27 mm screw of tempered steel.
- Damage to the workpiece is prevented by a brass clamping ring.

**Advantage:**

- Reduced tooling time and tool elements cuts tooling costs
- Optimal use of the machine table
- Tension on flat workpieces increased to make holes, threads and grooves

**Note:**

- Suitable for workpiece thicknesses from 8 to 40 mm
- Support height 80 mm
- Spacer elements of 25 mm and 50 mm are also available to increase the support height

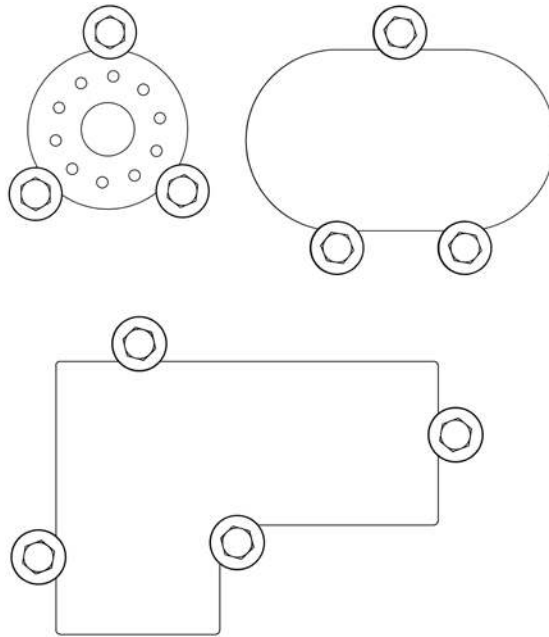
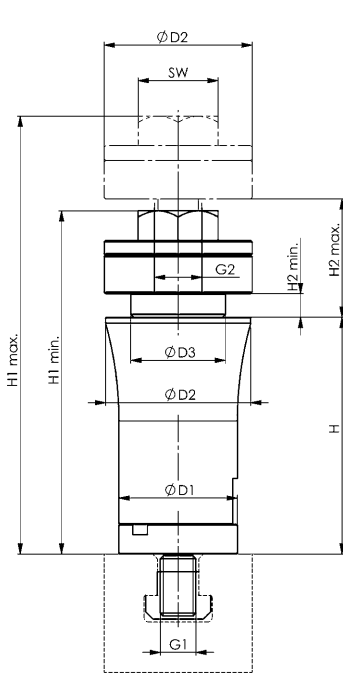
**Recommendations**

 No. 6417Z,  
page 85

CAD



Subject to technical alterations.

**No. 6417Z**
**Spacer element**

blued.

Order no.	Size	dia. D [mm]	H [mm]	Weight [g]
74195	25	40	25	214
74211	50	40	50	459

**Application:**

Used to increase the support height.

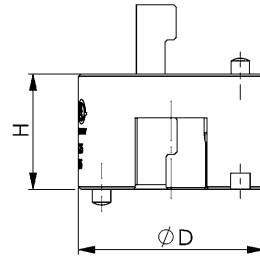

No. 6419

## Floating clamp

combined support and clamping,  
incl. fastening for T-slots.



Order no.	Size	Slot	G	Md min. - max. [Nm]	F [kN]	Setting travel H	Clamping stroke H2*	Weight [g]
75754	12	14	M12	15-30	2-8	102-112	0-12	1880
75622	16	18	M16	50-115	8-25	163-175	10-25	6250

\* Clamping stroke = clamping range with upper and lower standard clamping jaw.

### Application:

1. Fasten floating clamp on fixture or machine table.
2. Adjust height stop and swivel range with red adjustment sleeve and lock with threaded stud. When setting the upwards height limitation, allow for generous play (workpiece manufacturing tolerance).
3. Press floating clamp downwards.
4. Swivel clamping jaws in as far as they will go.
  - The floating clamp is positioned with light spring force on bottom of workpiece.
5. Tighten floating clamp with hexagon nut.
  - During the clamping process the workpiece is clamped and at the same time supported.
6. Unclamping is carried out in the reverse sequence.

### Advantage:

- Especially suitable for large, hard-to-machine components (size 16).
- No deformation when clamping weak components.
- Vibration suppression during machining.
- Clamping of ribs, creases and tabs for stiffening on clamped components.
- Deformation-free clamping of blanks.

### Note:

- The floating clamp is used to clamp and support overdetermined clamping points on components.
- For customer-specific clamping situations the supplied clamping jaws can be replaced with the following clamping jaws (Nos. 6419B-12 and 6418B-16) (max. tightening torque = 43 Nm)

Size 12

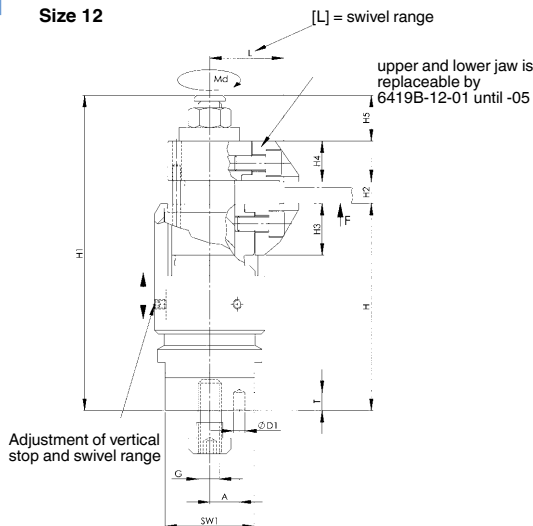

### Dimensions:

Order no.	Size	A	B	B1	D	ØD1 +0.3	H1	H3	H4	H5	L	SW2	SW1	L1	T
75754	12	14	28	15	57	6	163	26,8	21	32	39	18	46	46	8
75622	16	20	54	20	80	6	261	40,0	29	45	54	24	55	68	8

### Application examples:

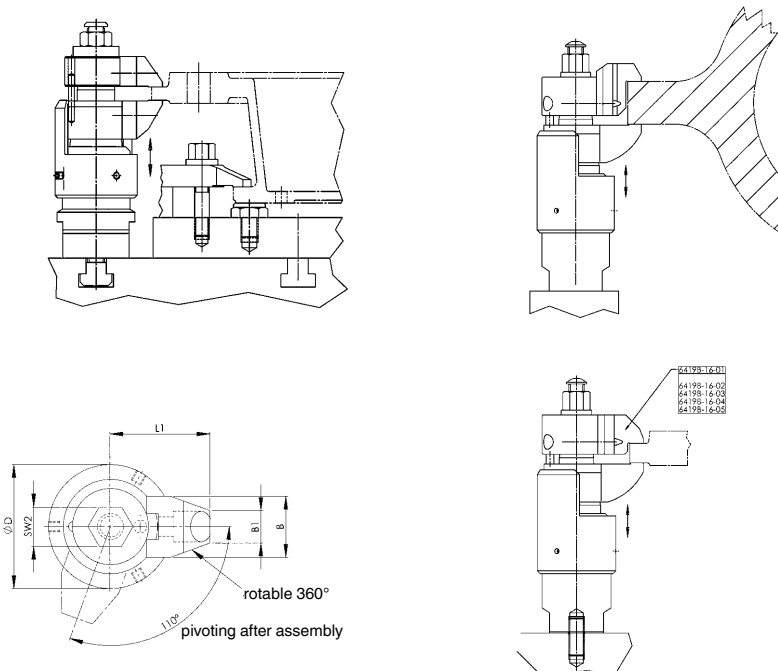

Size 16

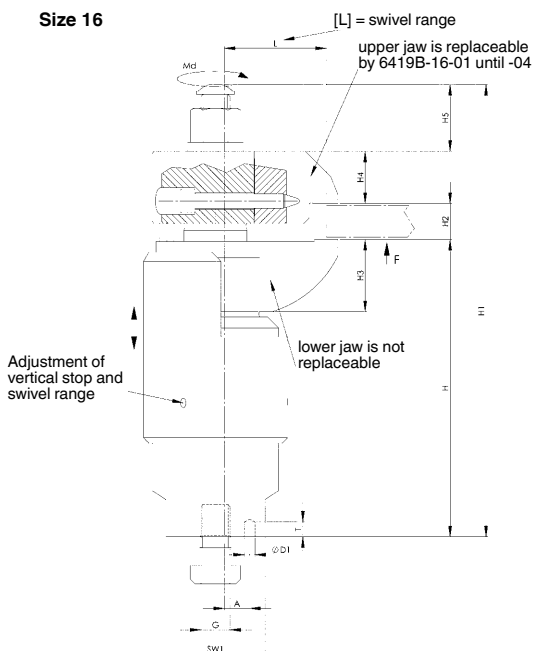

CAD



Subject to technical alterations.

## No. 6419B-12-01

### Clamping jaw

Case-hardened steel, nitrided and burnished.  
Lower standard clamping jaw.



Order no.	Size	B	B1	D	D1 +0,02	H -0,1	H1	H2 -0,1	H3 ±0,1	L	L1	T +0,2	T1	Weight [g]
71233	12	28	15	9	12	26,8	2,5	22,3	16,3	28	10	5,5	0,2	83

#### Note:

Fastening with ISO 4762-M8 cylinder bolts.

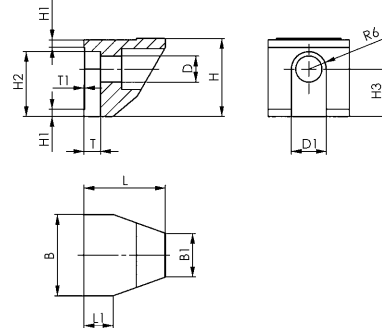

## No. 6419B-12-02

### Clamping jaw

Case-hardened steel, nitrided and burnished.  
Upper standard clamping jaw.



Order no.	Size	B	B1	D	D1 +0,02	H -0,1	H1	H2 -0,1	H3 ±0,1	L	L1	T +0,2	T1	Weight [g]
71605	12	28	15	9	12	21	2,5	17,5	11,5	29,5	11,5	5,5	0,2	71

Clamping range = workpiece thickness 0-12 mm.

#### Note:

Fastening with ISO 4762-M8 cylinder bolts.

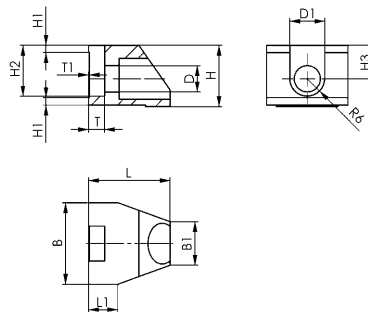

## No. 6419B-12-03

### Clamping jaw

Case-hardened steel, nitrided and burnished.  
Upper exchangeable clamping jaw.



Order no.	Size	B	B1	D	D1 +0,02	H -0,1	H1	H2 -0,1	H3 ±0,1	H4	L	L1	T +0,2	T1	Weight [g]
74229	12	28	15	9	12	24,5	2,5	21,5	15,5	3,5	29,5	11,5	5,5	0,2	94

Clamping range = workpiece thickness 4-16 mm.

#### Note:

Fastening with ISO 4762-M8 cylinder bolts.

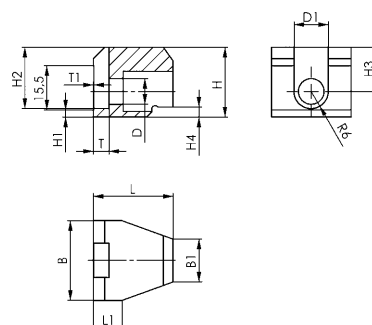

## No. 6419B-12-04

### Clamping jaw

Case-hardened steel, nitrided and burnished.  
Upper exchangeable clamping jaw.

Order no.	Size	B	B1	D	D1 +0,02	H -0,1	H1	H2 -0,1	H3 ±0,1	H4	L	L1	T +0,2	T1	Weight [g]
74245	12	28	15	9	12	24,5	2,5	21,5	15,5	14,5	29,5	11,5	5,5	0,2	90

Clamping range = workpiece thickness 15-27 mm.

#### Note:

Fastening with ISO 4762-M8 cylinder bolts.

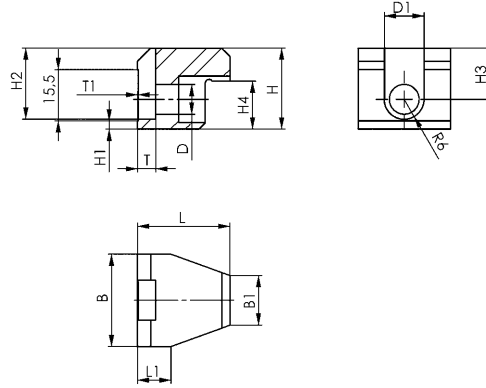

## No. 6419B-12-05

### Clamping jaw

Case-hardened steel, nitrided and burnished.  
Upper exchangeable clamping jaw.

Order no.	Size	B	B1	D	D1 +0,02	H -0,1	H1	H2 -0,1	H3 ±0,1	H4	L	L1	T +0,2	T1	Weight [g]
75051	12	28	15	9	12	35,5	2,5	32,5	26,5	25,5	29,5	11,5	5,5	0,2	132

Clamping range = workpiece thickness 26-38 mm.

#### Note:

Fastening with ISO 4762-M8 cylinder bolts.

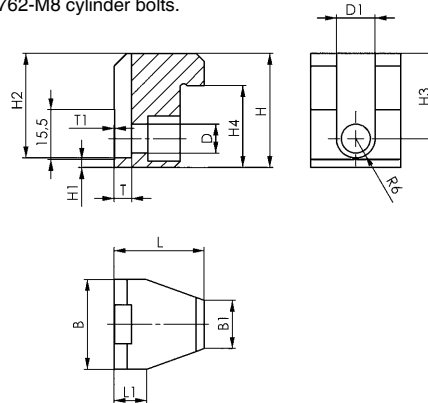

## No. 6419B-16-01

### Clamping jaw

Case-hardened steel, nitrided and manganese phosphatised.  
Upper standard clamping jaw.

Order no.	Size	H	H1	H2	H3	H4	Weight [g]
75382	16	40	29	33,3	32	27,6	400

Clamping range = workpiece thickness 10-25 mm.

#### Note:

Fastening with ISO 4762-M8x50 cylinder bolts.

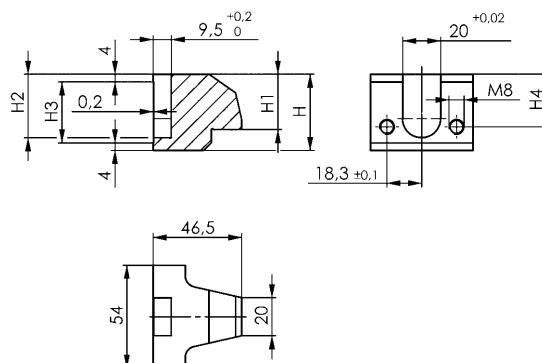

Subject to technical alterations.

## No. 6419B-16-02

### Clamping jaw

Case-hardened steel, nitrided and manganese phosphatised.  
Upper exchangeable clamping jaw.



Order no.	Size	H	H1	H2	H3	H4	Weight [g]
75424	16	40	41	33,3	32	27,6	380

Clamping range = workpiece thickness 0-14 mm.

#### Note:

Fastening with ISO 4762-M8x50 cylinder bolts.

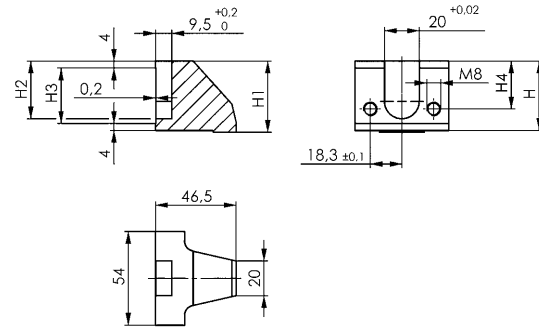

## No. 6419B-16-03

### Clamping jaw

Case-hardened steel, nitrided and manganese phosphatised.  
Upper exchangeable clamping jaw.



Order no.	Size	H	H1	H2	H3	H4	Weight [g]
75440	16	45	21,6	38,3	32	32,6	440

Clamping range = workpiece thickness 23-38 mm.

#### Note:

Fastening with ISO 4762-M8x50 cylinder bolts.

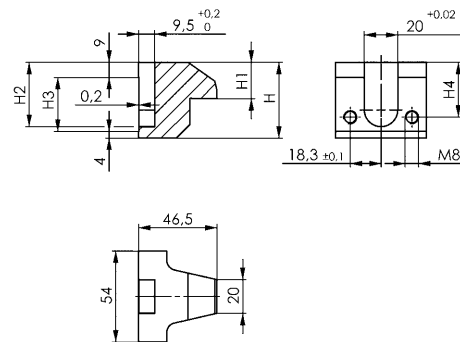

## No. 6419B-16-04

### Clamping jaw

Case-hardened steel, nitrided and manganese phosphatised.  
Upper exchangeable clamping jaw.



Order no.	Size	H	H1	H2	H3	H4	Weight [g]
75630	16	54	18,6	47,3	32	41,6	510

Clamping range = workpiece thickness 35-50 mm.

#### Note:

Fastening with ISO 4762-M8x50 cylinder bolts.

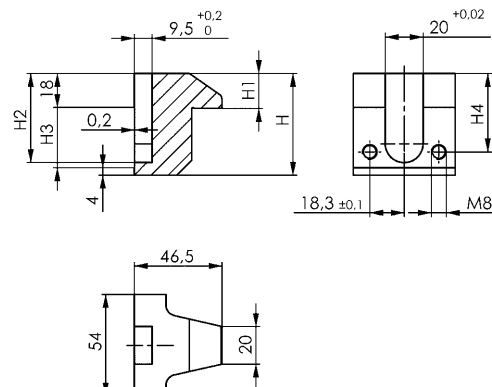

Subject to technical alterations.

## Application examples clamping jaw 6419B-12

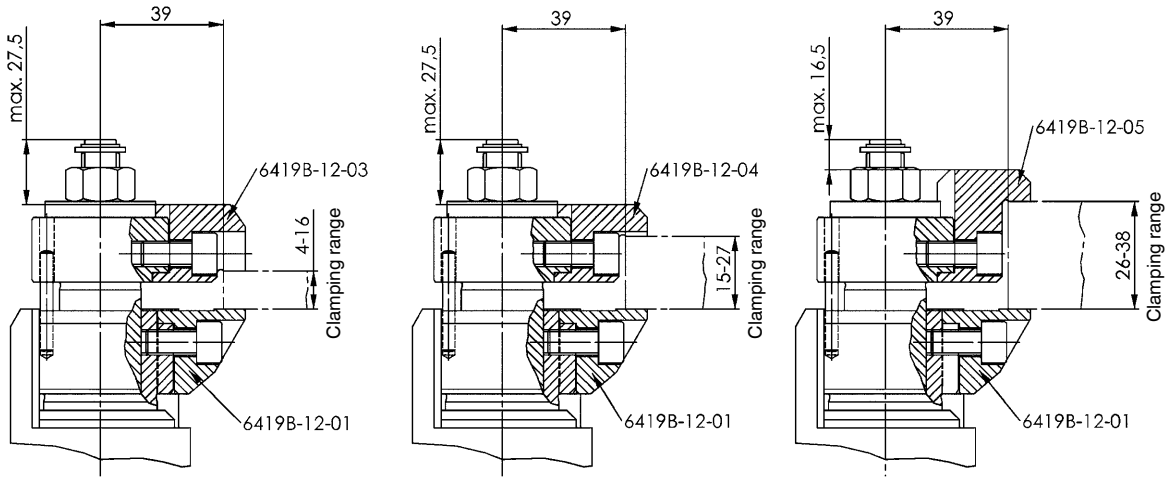

## Application examples clamping jaw 6419B-16

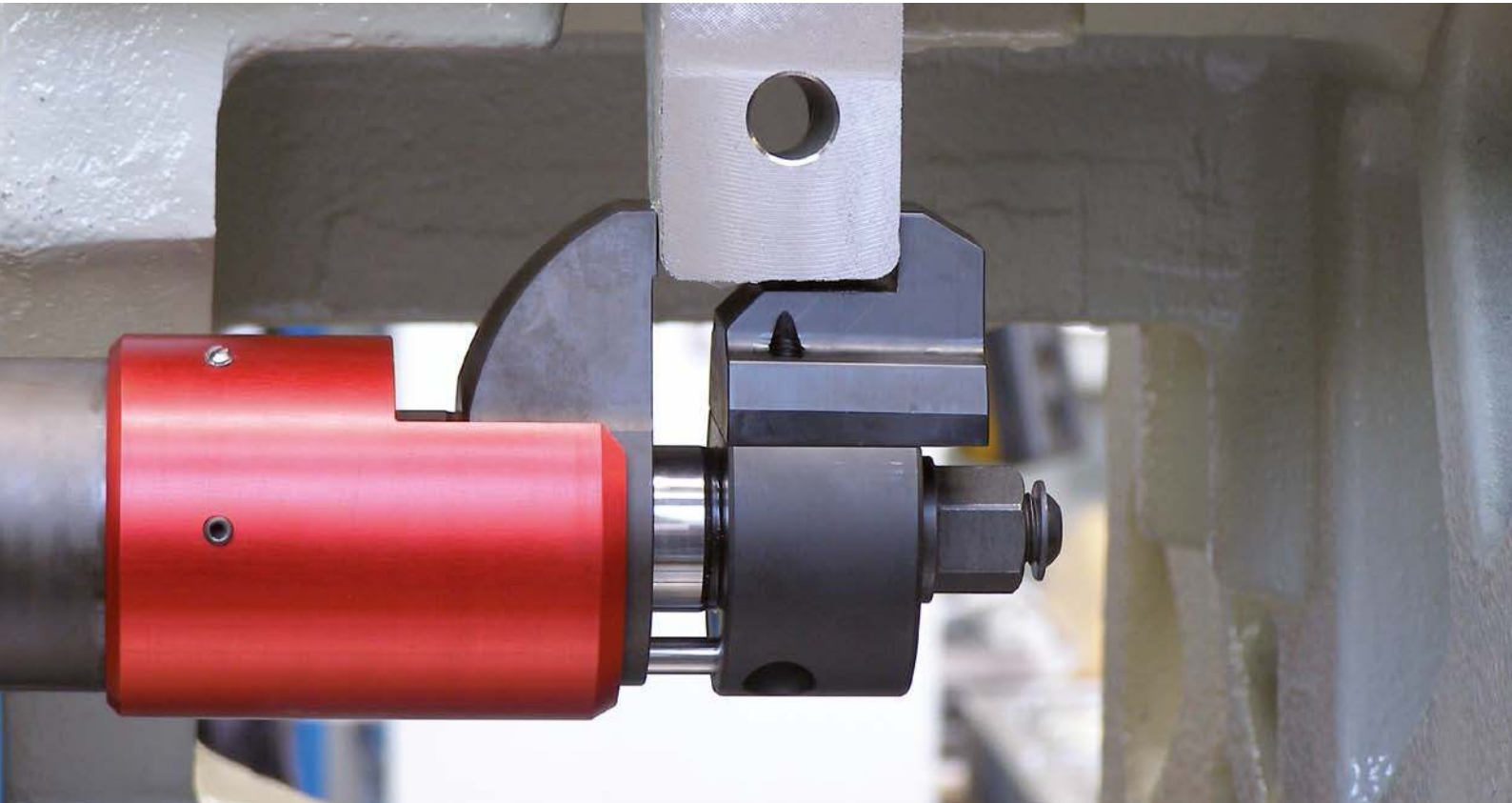
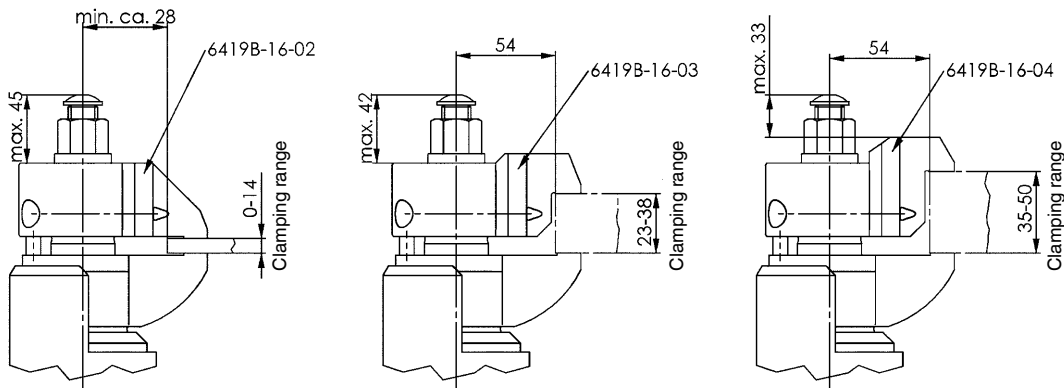

## CLAMPING BOLTS, NUTS AND WASHERS - QUALITY OF AMF

- > **Material:** Tempering steel to DIN regulations within tensile strength classes 8.8, 10.9 and 12.9.
- > **Machining:** All bolts and studs have rolled threads and guarantee high clamping forces and long life.
- > **Tempering:** Tensile strength classes according to DIN regulations.

Bolts, T-nuts and nuts are manufactured to DIN 267 and ISO 898. By galvanizing tempered and hardened components there is a certain risk of the material getting brittle. In the event of components being subsequently galvanized we refuse all possible claims regarding breakages and damages.

There are strong reasons for demanding operators to only use AMF-clamping bolts of highest quality:

- > Strict checks guarantee a consistent quality level.
- > High quality clamping bolts and nuts last longer, reduce tool management and idle periods resulting in more economy in the long run.

### Please notice!

The torque which can be achieved by hand can be higher than required by DIN standard for screws sizes up to 12 mm dia. Result: Only under worst conditions will the screw first of all twist and eventually break when overstressed. A small but decisive contribution to safety at the workplace.





**AMF-T-SLOT BOLTS** DIN 787 and No. 787

are manufactured within tensile strength classes 8.8, 10.9 and 12.9.

**AMF-STUDS** DIN 6379 and No. 6379

are manufactured within tensile strength classes 8.8, 10.9 and 12.9.

**AMF-HEXAGON NUTS** DIN 6330B, DIN 6331 and No. 6334

are manufactured within tensile strength class 10.

The individual characteristics in tensile strength classes 8.8, 10.9 and 12.9 are defined as follows:

- 8. = minimum tensile strength = 800 N/mm<sup>2</sup>
- .8 = minimum yield point (80% of min. tensile strength) = 640 N/mm<sup>2</sup>
- 10. = minimum tensile strength = 1000 N/mm<sup>2</sup>
- .9 = minimum yield point (90% of min. tensile strength) = 900 N/mm<sup>2</sup>
- 12. = minimum tensile strength = 1200 N/mm<sup>2</sup>
- .9 = minimum yield point (90% of min. tensile strength) = 1080 N/mm<sup>2</sup>

**STRENGTH OF HEXAGON NUTS:**

The individual characteristic in tensile strength class 10. defined is:

10. = minimum test strength = 1000 N/mm<sup>2</sup>

This test strength is equal to the minimum tensile strength of a screw which can be charged to its minimum breaking load, when matched with the respective nut.

A normal screw / nut combination for load transmission would be a nut of tensile strength class "8" for 8.8 screws. For manufacturing of this nut, a minor quality material than for 8.8 screws necessary could be used, since lower tensions occur in the nut, compared with screw. But since nuts require a high wear resistance in addition to sufficient strength, we manufacture them of the same material as our 8.8-screws. This results with tensile strength class "10" for nuts.

Clamping forces depending on lubrication.

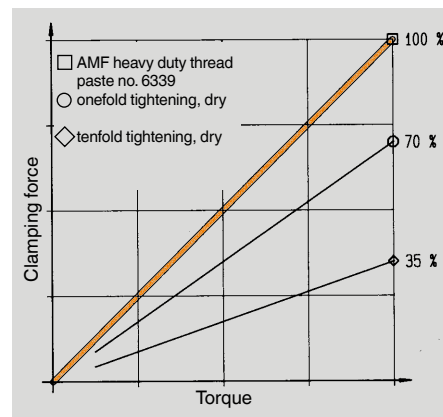

Test results revealed clearly:  
**Frequent use of non-greased bolt/nut connections in fixtures will reduce clamping forces considerably at still constant torques, with additional wear involved!**

We therefore recommend the AMF-Heavy-duty thread paste no. 6339. It has a synergetic acting combination of highly active white solid lubrications and is resistant to heat and wash-off. It provides optimal sliding characteristics for increased clamping force and improved thread life.

	Tensile strength classes			
	8.8	10.9	12.9	10
DIN 787 / No. 787 	X	X	X	-
DIN 6379 / No. 6379 	X	X	X	-
DIN 6330B DIN 6331 No. 6334 	-	-	-	X
Nominal tensile strength [N/mm <sup>2</sup> ]	800	1000	1200	1000*
Minimum yield point [N/mm <sup>2</sup> ]	640	900	1080	-

CHART OF PERMISSIBLE AND POSSIBLE PRE-STRESS FORCES:

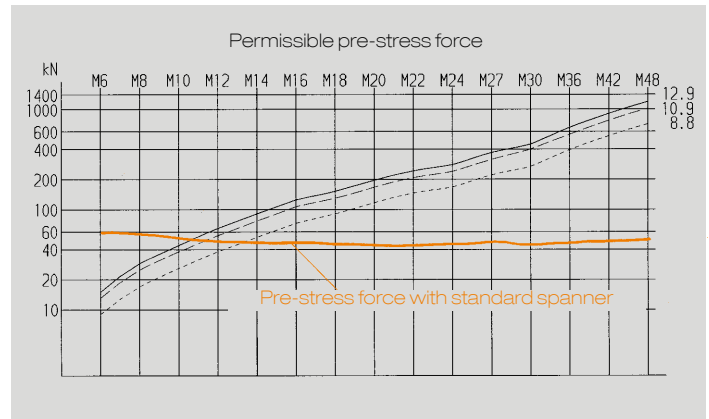

\* Strength figures of the right bolts

### EXPLANATION OF TABLE CHARACTERISTICS:

- > **PERMISSIBLE BOLT LOAD** is the maximum tension load, the screw can be stressed with taking into account all active forces. The yield point is only utilized to 80% for safety.
- > **PERMISSIBLE PRE-STRESS FORCE** is the load, the screw can be pre-stressed at most, when tightening the matching nut. Figures of table are valid for a friction of  $\mu = 0,14$  in thrust faces and thread, corresponding to the friction of greased medium faces.
- > **REQUIRED LENGTH FOR LEVER OF SPANNER:** These length figures were calculated with the mean value of hand forces achieved in test series by different workmen.

### STRENGTH FIGURES AND TORQUES FOR BOLTS AND NUTS:

Thread	Tensile	M6	M8	M10	M12	M14	M16	M18	M20	M22	M24	M27	M30	M36	M42	M48	
Pitch of thread		mm	1	1.25	1.50	1.75	2	2	2.50	2.50	2.50	3	3	3.50	4	4.50	5
<b>Nuts:</b>																	
Hardness DIN6330/6331/6334	HRC	10	26 - 36												20 - 30		
Test force (AS x Sp) DIN EN ISO 898-2	kN	10	20.9	38.1	60.3	88.5	120.8	164.9	203.5	259.7	321.2	374.2	486.5	594.7	866	-	-
<b>Nuts for T-slots DIN508/DIN508L:</b>																	
Size		M6x8	M8x10	M10x12	M12x14	-	M16x18	-	M20x22	-	M24x28	-	M30x36	M36x42	M42x48	M48x54	
Hardness	HRC	22 - 30															
Test force to DIN 508	kN	16	29	46	67	-	128	-	196	-	282	-	448	653	653	653	
<b>Bolts:</b>																	
Hardness	HRC	8.8	22 - 32					32 - 39					23 - 34				
		10.9															
		12.9															

### PERMITTED SCREW LOADS AND TIGHTENING TORQUES:

		8.8	10.9	12.9	10	8.8	10.9	12.9	10	8.8	10.9	12.9	10	8.8	10.9	12.9	10
Minimum breaking force (AS x R <sub>m</sub> )	kN	8.8	16	29	46	67	92	125	159	203	252	293	381	466	678	930	1222
		10.9	21	38	60	88	120	163	200	255	315	367	477	583	850	1165	1531
		12.9	24	45	71	103	140	192	234	299	370	431	560	684	997	1367	1797
Permissible bolt load max. 80% of yield point	kN	8.8	10	19	30	43	59	80	101	129	160	186	242	296	431	591	777
		10.9	14	27	43	63	86	118	144	184	228	265	345	421	614	843	1107
		12.9	17	32	51	74	101	138	169	215	266	310	404	493	719	986	1296
Test force (AS x Sp) to DIN EN ISO 898, part 1	kN	8.8	12	21	34	49	67	91	115	147	182	212	275	337	490	672	882
		10.9	17	30	48	70	96	130	159	203	252	293	381	466	678	930	1222
		12.9	20	35	56	82	112	152	186	238	294	342	445	544	792	1087	1428
Permissible pre-stress force max. 90% of yield point and friction $\mu = 0,14$	kN	8.8	9	17	26	38	53	73	91	117	146	168	221	269	394	542	714
		10.9	13	25	38	55	77	107	130	167	208	240	315	384	561	773	1018
		12.9	15	29	44	65	91	125	152	196	243	281	369	449	657	904	1191
Necessary tightening torque for permissible pre-tensioning force and a friction of $\mu=0,14$	Nm	8.8	10	25	46	82	130	206	284	407	542	698	1021	1355	2372	3802	5730
		10.9	14	36	67	120	191	302	405	580	772	994	1455	1930	3378	5415	8162
		12.9	17	43	79	141	223	354	474	679	903	1163	1703	2258	3953	6337	9571
Required length for lever to achieve permissible pre-stress force	mm	8.8	30	67	120	205	310	479	645	900	1130	1395	-	-	-	-	-
		10.9	42	97	175	300	545	700	920	1285	1600	1980	-	-	-	-	-
		12.9	51	116	207	352	530	823	1075	1500	1880	2300	-	-	-	-	-
Combination wrench test torque in accordance with ISO 1711-1	Nm	-	58	107	175	230	330	451	594	760	884	1165	1579	2067	3140	4021	5394

AS = nominal cross section in mm<sup>2</sup> / Sp = min. clamping force in N/mm<sup>2</sup> / R<sub>m</sub> = minimum tensile strength in N/mm<sup>2</sup> /  $\mu$  = friction

## DIN 787

### Bolts for T-slots

forged, T-slot guide cleared, rolled thread, stamped with AMF logo and strength class. M6 to M12 tempered to strength class 10.9, M14 to M42 tempered to strength class 8.8.

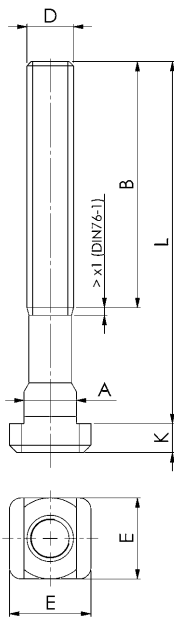

#### Recommendations



DIN 6331,  
page 108



DIN 6340,  
page 113

Order no.	D x Slot x L	Strength class	A	B	E	K	Packaging Unit	Weight [g]
84004	M6x6x25	10.9	5,7	15	10	4	25	9
84012	M6x6x40	10.9	5,7	28	10	4	25	12
84038	M8x8x32	10.9	7,7	22	13	6	25	20
80374	M8x8x50	10.9	7,7	35	13	6	25	25
80382	M8x8x80	10.9	7,7	50	13	6	25	30
84046	M10x10x40	10.9	9,7	30	15	6	25	30
80390	M10x10x63	10.9	9,7	45	15	6	25	50
81323	M10x10x80 *	10.9	9,7	50	15	6	25	60
80408	M10x10x100	10.9	9,7	60	15	6	25	70
80416	M12x12x50 *	10.9	11,7	33	18	7	25	60
85605	M12x12x63 *	10.9	11,7	40	18	7	25	65
80424	M12x12x80	10.9	11,7	55	18	7	25	75
81406	M12x12x100 *	10.9	11,7	65	18	7	25	90
80432	M12x12x125	10.9	11,7	75	18	7	25	110
81497	M12x12x160 *	10.9	11,7	100	18	7	-	135
80440	M12x12x200	10.9	11,7	120	18	7	-	160
80457	M12x14x50	10.9	13,7	35	22	8	25	70
85613	M12x14x63 *	10.9	13,7	45	22	8	25	80
80465	M12x14x80	10.9	13,7	55	22	8	25	100
81851	M12x14x100 *	10.9	13,7	65	22	8	25	110
80473	M12x14x125	10.9	13,7	75	22	8	25	120
82966	M12x14x160 *	10.9	13,7	100	22	8	-	150
80481	M12x14x200	10.9	13,7	120	22	8	-	180
80499	M14x16x63 *	8.8	15,7	45	25	9	25	115
84426	M14x16x80 *	8.8	15,7	55	25	9	25	130
80507	M14x16x100 *	8.8	15,7	65	25	9	25	150
84434	M14x16x125 *	8.8	15,7	75	25	9	25	180
80515	M14x16x160 *	8.8	15,7	100	25	9	25	220
80523	M14x16x250 *	8.8	15,7	150	25	9	-	300
80531	M16x16x63 *	8.8	15,7	45	25	9	25	140
85621	M16x16x80 *	8.8	15,7	55	25	9	10	160
80549	M16x16x100 *	8.8	15,7	65	25	9	10	180
84384	M16x16x125 *	8.8	15,7	85	25	9	10	225
80556	M16x16x160 *	8.8	15,7	100	25	9	10	270
85647	M16x16x200 *	8.8	15,7	125	25	9	-	315
80564	M16x16x250 *	8.8	15,7	150	25	9	-	380
80572	M16x18x63	8.8	17,7	45	28	10	25	160
85639	M16x18x80 *	8.8	17,7	55	28	10	10	185
80580	M16x18x100	8.8	17,7	65	28	10	10	203
84400	M16x18x125 *	8.8	17,7	85	28	10	10	230
80598	M16x18x160	8.8	17,7	100	28	10	10	280
85654	M16x18x200 *	8.8	17,7	125	28	10	-	330
80606	M16x18x250	8.8	17,7	150	28	10	-	430
84103	M20x20x80 *	8.8	19,7	55	32	12	-	290
84053	M20x20x100 *	8.8	19,7	65	32	12	-	340
84111	M20x20x125 *	8.8	19,7	85	32	12	-	390
85662	M20x20x160 *	8.8	19,7	110	32	12	-	470
84129	M20x20x200 *	8.8	19,7	125	32	12	-	550
84079	M20x20x250 *	8.8	19,7	150	32	12	-	670
84137	M20x20x315 *	8.8	19,7	190	32	12	-	800
80614	M20x22x80	8.8	21,7	55	35	14	-	330
85829	M20x22x100 *	8.8	21,7	65	35	14	-	370
80622	M20x22x125	8.8	21,7	85	35	14	-	428
85670	M20x22x160 *	8.8	21,7	110	35	14	-	500
80630	M20x22x200	8.8	21,7	125	35	14	-	570
85845	M20x22x250 *	8.8	21,7	150	35	14	-	680
80648	M20x22x315	8.8	21,7	190	35	14	-	820
80770	M24x24x100 *	8.8	23,7	70	40	16	-	540
85688	M24x24x125 *	8.8	23,7	85	40	16	-	600
80788	M24x24x160 *	8.8	23,7	110	40	16	-	770
85704	M24x24x200 *	8.8	23,7	125	40	16	-	900
80796	M24x24x250 *	8.8	23,7	150	40	16	-	960
84061	M24x24x315 *	8.8	23,7	190	40	16	-	1270
80804	M24x24x400 *	8.8	23,7	240	40	16	-	1410
80655	M24x28x100	8.8	27,7	70	44	18	-	650
85696	M24x28x125 *	8.8	27,7	85	44	18	-	720
80663	M24x28x160	8.8	27,7	110	44	18	-	800
85712	M24x28x200 *	8.8	27,7	125	44	18	-	950
80671	M24x28x250	8.8	27,7	150	44	18	-	1120

Subject to technical alterations.

## DIN 787

### Bolts for T-slots

forged, T-slot guide cleared, rolled thread, stamped with AMF logo and strength class. M6 to M12 tempered to strength class 10.9, M14 to M42 tempered to strength class 8.8.

Order no.	D x Slot x L	Strength class	A	B	E	K	Packaging Unit	Weight [g]
84087	M24x28x315 *	8.8	27,7	190	44	18	-	1350
80689	M24x28x400 *	8.8	27,7	240	44	18	-	1490
87643	M27x32x160 *	8.8	31,6	100	50	20	-	1168
87783	M27x32x200 *	8.8	31,6	135	50	20	-	1345
80697	M30x36x125	8.8	35,6	80	54	22	-	1250
85720	M30x36x160 *	8.8	35,6	110	54	22	-	1440
80705	M30x36x200	8.8	35,6	135	54	22	-	1630
85738	M30x36x250 *	8.8	35,6	150	54	22	-	1920
80713	M30x36x315	8.8	35,6	200	54	22	-	2100
80721	M30x36x500	8.8	35,6	300	54	22	-	3300
80739	M36x42x160	8.8	41,6	100	65	26	-	2200
80747	M36x42x250	8.8	41,6	175	65	26	-	2820
80754	M36x42x400	8.8	41,6	250	65	26	-	3930
84152	M42x48x250	8.8	47,6	175	75	30	-	4300
84160	M42x48x400	8.8	47,6	250	75	30	-	5800

\* Size not included in DIN, dimensions similar to DIN

### Advantage:

#### Benefits of thread rolling:

- no interrupted fibre orientation
- reduced notch sensitivity
- very good roughness values on the thread flanks and in the base radius



## No. 787

### Bolts for T-slots, complete

with DIN 787 screws for T-slots, hexagon nut DIN 6330B and washer DIN 6340.

Forged, T-slot guide cleared, rolled thread, stamped with AMF logo and strength class. M6 to M12 tempered to strength class 10.9, M14 to M42 tempered to strength class 8.8.

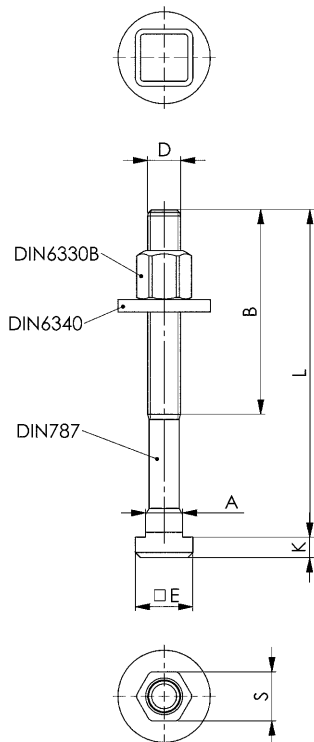

Order no.	D x Slot x L	Strength class	A	B	E	K	S	Weight [g]
84202	M6x6x25	10.9	5,7	15	10	4	10	19
84210	M6x6x40	10.9	5,7	28	10	4	10	22
84236	M8x8x32	10.9	7,7	22	13	6	13	40
80812	M8x8x50	10.9	7,7	35	13	6	13	45
80820	M8x8x80	10.9	7,7	50	13	6	13	55
84244	M10x10x40	10.9	9,7	30	15	6	16	65
80838	M10x10x63	10.9	9,7	45	15	6	16	80
81356	M10x10x80	10.9	9,7	50	15	6	16	90
80846	M10x10x100	10.9	9,7	60	15	6	16	110
80853	M12x12x50	10.9	11,7	35	18	7	18	120
85746	M12x12x63	10.9	11,7	40	18	7	18	128
80861	M12x12x80	10.9	11,7	55	18	7	18	130
81448	M12x12x100	10.9	11,7	65	18	7	18	145
80879	M12x12x125	10.9	11,7	75	18	7	18	170
81505	M12x12x160	10.9	11,7	100	18	7	18	195
80887	M12x12x200	10.9	11,7	120	18	7	18	220
80895	M12x14x50	10.9	13,7	35	22	8	18	130
85753	M12x14x63	10.9	13,7	45	22	8	18	145
80903	M12x14x80	10.9	13,7	55	22	8	18	155
82974	M12x14x100	10.9	13,7	65	22	8	18	165
80911	M12x14x125	10.9	13,7	75	22	8	18	180
84376	M12x14x160	10.9	13,7	100	22	8	18	210
80929	M12x14x200	10.9	13,7	120	22	8	18	240
80937	M14x16x63	8.8	15,7	45	25	9	21	200
84442	M14x16x80	8.8	15,7	55	25	9	21	220
80945	M14x16x100	8.8	15,7	65	25	9	21	230
84459	M14x16x125	8.8	15,7	75	25	9	21	280
80952	M14x16x160	8.8	15,7	100	25	9	21	310
80960	M14x16x250	8.8	15,7	120	25	9	21	390
80978	M16x16x63	8.8	15,7	45	25	9	24	250
85761	M16x16x80	8.8	15,7	55	25	9	24	275
80986	M16x16x100	8.8	15,7	65	25	9	24	290
84392	M16x16x125	8.8	15,7	85	25	9	24	300
80994	M16x16x160	8.8	15,7	100	25	9	24	380
85779	M16x16x200	8.8	15,7	125	25	9	24	435
81000	M16x16x250	8.8	15,7	150	25	9	24	530
81018	M16x18x63	8.8	17,7	45	28	10	24	260
85787	M16x18x80	8.8	17,7	55	28	10	24	305
81026	M16x18x100	8.8	17,7	65	28	10	24	315
84418	M16x18x125	8.8	17,7	85	28	10	24	360
81034	M16x18x160	8.8	17,7	100	28	10	24	400
85795	M16x18x200	8.8	17,7	125	28	10	24	448
81042	M16x18x250	8.8	17,7	150	28	10	24	560
84301	M20x20x80	8.8	19,7	55	32	12	30	520
81547	M20x20x100	8.8	19,7	65	32	12	30	570
84319	M20x20x125	8.8	19,7	85	32	12	30	600
85803	M20x20x160	8.8	19,7	110	32	12	30	680
84327	M20x20x200	8.8	19,7	125	32	12	30	750
81562	M20x20x250	8.8	19,7	150	32	12	30	800
84335	M20x20x315	8.8	19,7	190	32	12	30	940
81059	M20x22x80	8.8	21,7	55	35	14	30	530
85837	M20x22x100	8.8	21,7	65	35	14	30	610
81067	M20x22x125	8.8	21,7	85	35	14	30	670
85811	M20x22x160	8.8	21,7	110	35	14	30	710
81075	M20x22x200	8.8	21,7	125	35	14	30	750
85852	M20x22x250	8.8	21,7	150	35	14	30	850
81083	M20x22x315	8.8	21,7	190	35	14	30	980
81216	M24x24x100	8.8	23,7	70	40	16	36	910
85860	M24x24x125	8.8	23,7	85	40	16	36	970
81224	M24x24x160	8.8	23,7	110	40	16	36	1040
85878	M24x24x200	8.8	23,7	125	40	16	36	1265
81232	M24x24x250	8.8	23,7	150	40	16	36	1410
81588	M24x24x315	8.8	23,7	190	40	16	36	1640
81240	M24x24x400	8.8	23,7	240	40	16	36	1780
81091	M24x28x100	8.8	27,7	70	44	18	36	980
85886	M24x28x125	8.8	27,7	85	44	18	36	1010
81109	M24x28x160	8.8	27,7	110	44	18	36	1150
85894	M24x28x200	8.8	27,7	125	44	18	36	1240
81117	M24x28x250	8.8	27,7	150	44	18	36	1500

Subject to technical alterations.

## No. 787

### Bolts for T-slots, complete

with DIN 787 screws for T-slots, hexagon nut DIN 6330B and washer DIN 6340.

Forged, T-slot guide cleared, rolled thread, stamped with AMF logo and strength class. M6 to M12 tempered to strength class 10.9, M14 to M42 tempered to strength class 8.8.

Order no.	D x Slot x L	Strength class	A	B	E	K	S	Weight [g]
81604	M24x28x315	8.8	27,7	190	44	18	36	1730
81125	M24x28x400	8.8	27,7	240	44	18	36	1860
81133	M30x36x125	8.8	35,6	80	54	22	46	1860
85902	M30x36x160	8.8	35,6	110	54	22	46	1950
81141	M30x36x200	8.8	35,6	135	54	22	46	2230
85910	M30x36x250	8.8	35,6	150	54	22	46	2555
81158	M30x36x315	8.8	35,6	200	54	22	46	2950
81166	M30x36x500	8.8	35,6	300	54	22	46	3950
81174	M36x42x160	8.8	41,6	100	65	26	55	3220
81182	M36x42x250	8.8	41,6	175	65	26	55	3840
81190	M36x42x400	8.8	41,6	250	65	26	55	4950
84186	M42x48x250	8.8	47,6	175	75	30	65	6900
84194	M42x48x400	8.8	47,6	250	75	30	65	8400

### Advantage:

#### Benefits of thread rolling:

- no interrupted fibre orientation
- reduced notch sensitivity
- very good roughness values on the thread flanks and in the base radius

### Note:

AMF quality starts with controlled raw material!

Our fully-automated forging plant produces clamping screws. Once cleared, the thread is rolled.



Subject to technical alterations.



## No. 787

### Screws for T-slot, strength class 12.9

Forged, T-slot guid-faces broached, rolled. Thread, tempered. Strength class punched into head.

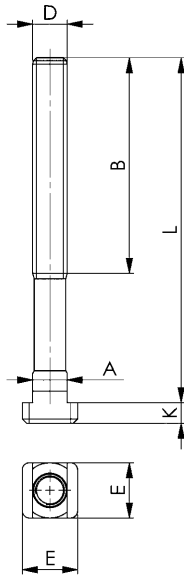

Order no.	D x Slot x L	A	B	E	K	Packaging Unit	Weight [g]
83956	M10x10x40	9,7	30	15	6	25	30
83972	M10x10x50	9,7	35	15	6	25	40
83998	M10x10x80	9,7	50	15	6	25	60
83923	M10x10x100	9,7	60	15	6	25	70
86140	M12x12x50	11,7	35	18	7	25	60
86231	M12x12x63	11,7	40	18	7	25	65
86157	M12x12x80	11,7	55	18	7	25	75
86256	M12x12x100	11,7	65	18	7	25	90
86165	M12x12x125	11,7	75	18	7	25	110
87304	M12x12x160	11,7	100	18	7	-	135
86173	M12x12x200	11,7	120	18	7	-	160
86181	M12x14x50	13,7	35	22	8	25	70
86611	M12x14x63	13,7	45	22	8	25	80
86199	M12x14x80	13,7	55	22	8	25	100
86678	M12x14x100	13,7	65	22	8	25	110
86207	M12x14x125	13,7	75	22	8	25	120
87320	M12x14x160	13,7	100	22	8	-	150
86215	M12x14x200	13,7	120	22	8	-	180
86264	M16x16x63	15,7	45	25	9	25	140
87346	M16x16x80	15,7	55	25	9	10	160
86272	M16x16x100	15,7	65	25	9	10	180
87361	M16x16x125	15,7	85	25	9	10	225
86280	M16x16x160	15,7	100	25	9	10	270
86298	M16x16x250	15,7	150	25	9	-	380
86306	M16x18x63	17,7	45	28	10	25	160
86629	M16x18x80	17,7	55	28	10	10	185
86314	M16x18x100	17,7	65	28	10	10	203
86645	M16x18x125	17,7	85	28	10	10	230
86322	M16x18x160	17,7	100	28	10	10	280
87403	M16x18x200	17,7	125	28	10	-	330
86330	M16x18x250	17,7	150	28	10	-	430
86421	M20x20x80	19,7	55	32	12	-	290
86439	M20x20x125	19,7	85	32	12	-	390
87429	M20x20x160	19,7	110	32	12	-	470
86447	M20x20x200	19,7	125	32	12	-	550
87437	M20x20x250	19,7	150	32	12	-	670
86454	M20x20x315	19,7	190	32	12	-	800
86348	M20x22x80	21,7	55	35	14	-	330
86355	M20x22x125	21,7	85	35	14	-	428
87445	M20x22x160	21,7	110	35	14	-	500
86363	M20x22x200	21,7	125	35	14	-	570
87510	M20x22x250	21,7	150	35	14	-	680
86371	M20x22x315	21,7	190	35	14	-	820
86462	M24x24x100	23,7	70	40	16	-	540
86470	M24x24x160	23,7	110	40	16	-	770
87577	M24x24x200	23,7	125	40	16	-	900
86488	M24x24x250	23,7	150	40	16	-	960
86496	M24x24x400	23,7	240	40	16	-	1410
86389	M24x28x100	27,7	70	44	18	-	650
86397	M24x28x160	27,7	110	44	18	-	800
87585	M24x28x200	27,7	125	44	18	-	950
86405	M24x28x250	27,7	150	44	18	-	1120
86413	M24x28x400	27,7	240	44	18	-	1490
81281	M30x36x160	35,6	110	54	22	-	1950
81364	M30x36x200	35,6	135	54	22	-	2230
81463	M30x36x250	35,6	150	54	22	-	2555

#### Advantage:

- higher strength class compared to DIN 787

#### Benefits of thread rolling:

- no interrupted fibre orientation
- reduced notch sensitivity
- very good roughness values on the thread flanks and in the base radius

#### Recommendations



DIN 6330B,  
page 107



DIN 6340,  
page 113



Subject to technical alterations.

No. 797

## Rhombus-head screws for T-slots

forged, T-slots milled, rolled thread, heat-treated.



Order no.	D x Slot x L	Strength class	A	B	E	K	Weight [g]
87296	M12x14x 50	8.8	13,7	35	22	8	70
87312	M12x14x 80	8.8	13,7	55	22	8	100
87338	M12x14x125	8.8	13,7	75	22	8	120
87353	M16x18x 63	8.8	17,7	45	28	10	160
87379	M16x18x100	8.8	17,7	65	28	10	220
87395	M16x18x160	8.8	17,7	100	28	10	280
86793	M20x22x 80	8.8	21,7	55	35	14	330
86801	M20x22x125	8.8	21,7	85	35	14	430
86819	M20x22x200	8.8	21,7	120	35	14	570
86959	M24x28x125	8.8	27,7	85	44	18	770
87114	M24x28x250	8.8	27,7	150	44	18	1120

### Application:

- additional setup of a clamping point for a previously clamped fixture
- subsequent setup of a clamping point for previously occupied machine table T-slot
- Insertion of the rhombus-head screw from above into the T-slot and turning up to the stop in the T-slot
- This is also possible with the combination of rhombus-head screw no. 510 and stud DIN 6379

### Advantage:

#### Benefits of thread rolling:

- no interrupted fibre orientation
- reduced notch sensitivity
- very good roughness values on the thread flanks and in the base radius

### Note:

Owing to the reduced contact surface in the T-slot, the max. permissible screw load capacity corresponds to the values for strength class 8.8. Matching nuts DIN 6330B and washers DIN 6340.

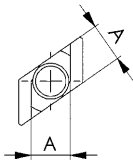
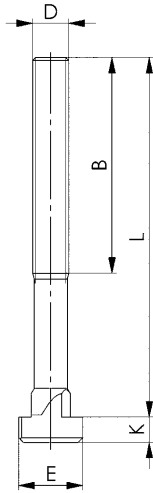

### Recommendations



DIN 6331,  
page 108



DIN 6340,  
page 113



Subject to technical alterations.



## DIN 6379

### Studs for nuts and T-slots

Rolled thread. M 6-M12 tempered to strength class 10.9, M14-M42 tempered to strength class 8.8.

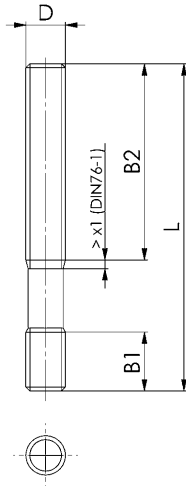

#### Recommendations



DIN 6331,  
page 108



DIN 6340,  
page 113

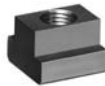

DIN 508,  
page 104

Order no.	D x L	Strength class	B1	B2	Packaging Unit	Weight [g]
84772	M 6x 32 *	10.9	9	16	50	8
86546	M 6x 40 *	10.9	9	20	50	9
84780	M 6x 50	10.9	9	30	50	11
85522	M 6x 63 *	10.9	9	40	50	14
84798	M 6x 80	10.9	9	50	50	18
81257	M 8x 40	10.9	11	20	100	10
84806	M 8x 63	10.9	11	40	50	20
81273	M 8x 80 *	10.9	11	50	50	25
84814	M 8x100	10.9	11	63	50	30
84756	M 8x125 *	10.9	11	75	50	36
84822	M 8x160 *	10.9	11	100	50	45
81299	M10x 50	10.9	13	25	50	25
84830	M10x 80	10.9	13	50	50	40
86041	M10x100 *	10.9	13	75	50	50
81315	M10x125	10.9	13	75	25	62
85928	M10x160 *	10.9	13	100	50	80
84848	M10x200	10.9	13	125	-	100
84855	M12x 50	10.9	15	25	25	37
81331	M12x 63 *	10.9	15	32	25	45
84863	M12x 80	10.9	15	50	50	55
81349	M12x100 *	10.9	15	63	50	70
84871	M12x125	10.9	15	75	25	90
85480	M12x160 *	10.9	15	100	25	113
84889	M12x200 *	10.9	15	125	-	140
81372	M14x 63 *	8.8	17	32	25	80
84467	M14x80 *	8.8	17	50	25	85
81380	M14x100 *	8.8	17	63	25	90
84475	M14x125 *	8.8	17	75	25	120
81398	M14x160 *	8.8	17	100	25	150
86553	M14x200 *	8.8	17	125	-	195
84897	M14x250 *	8.8	17	160	-	240
84905	M16x 63	8.8	19	32	25	85
81414	M16x 80 *	8.8	19	50	25	105
84913	M16x100	8.8	19	63	25	130
81422	M16x125 *	8.8	19	75	25	160
84921	M16x160	8.8	19	100	25	218
85498	M16x200 *	8.8	19	125	-	280
84939	M16x250	8.8	19	160	-	325
85548	M16x315 *	8.8	19	190	-	425
85472	M16x500 *	8.8	19	315	-	650
84947	M18x 80 *	8.8	23	50	25	130
84954	M18x125 *	8.8	23	75	25	200
86561	M18x160 *	8.8	23	100	-	255
81471	M18x200 *	8.8	23	125	-	320
81489	M18x250 *	8.8	23	150	-	400
84962	M18x315 *	8.8	23	180	-	500
84970	M20x 80	8.8	27	32	-	185
84988	M20x125	8.8	27	70	-	255
85506	M20x160 *	8.8	27	100	-	330
81513	M20x200	8.8	27	125	-	410
81521	M20x250 *	8.8	27	160	-	510
84996	M20x315	8.8	27	190	-	640
85977	M20x400 *	8.8	27	250	-	815
85001	M20x500 *	8.8	27	315	-	1020
85019	M22x100 *	8.8	31	45	-	270
81539	M22x160 *	8.8	31	100	-	430
86579	M22x200 *	8.8	31	125	-	500
86595	M22x315 *	8.8	31	190	-	790
85027	M22x400 *	8.8	31	250	-	1070
85035	M24x100	8.8	35	45	-	290
85563	M24x125 *	8.8	35	70	-	380
81570	M24x160	8.8	35	100	-	470
85514	M24x200 *	8.8	35	125	-	580
81596	M24x250	8.8	35	160	-	730
86009	M24x315 *	8.8	35	190	-	920
85043	M24x400	8.8	35	250	-	1160
86025	M24x500 *	8.8	35	315	-	1460
85050	M24x630 *	8.8	35	315	-	1860
81695	M27x125 *	8.8	39	56	-	485

Subject to technical alterations.

## DIN 6379

### Studs for nuts and T-slots

Rolled thread. M 6-M12 tempered to strength class 10.9,  
M14-M42 tempered to strength class 8.8.

Order no.	D x L	Strength class	B1	B2	Packaging Unit	Weight [g]
81703	M27x200 *	8.8	39	125	-	770
81711	M27x315 *	8.8	39	190	-	1110
86587	M27x400 *	8.8	39	250	-	1535
85068	M30x125	8.8	43	56	-	590
81612	M30x200 *	8.8	43	125	-	950
81620	M30x315	8.8	43	190	-	1490
81638	M30x500	8.8	43	315	-	2360
81646	M30x700 *	8.8	43	400	-	3300
81661	M30x1000 *	8.8	43	400	-	4700
85076	M36x160	8.8	51	80	-	1100
81653	M36x200 *	8.8	51	125	-	1340
85084	M36x250	8.8	51	160	-	1710
85555	M36x315 *	8.8	51	190	-	2150
85092	M36x400	8.8	51	250	-	2700
81679	M36x500 *	8.8	51	315	-	3450
85589	M42x315 *	8.8	59	190	-	2950

\* Size not included in DIN, dimensions similar to DIN

### Advantage:

#### Benefits of thread rolling:

- no interrupted fibre orientation
- reduced notch sensitivity
- very good roughness values on the thread flanks and in the base radius



Subject to technical alterations.



## No. 6379

### Studs for nuts and T-slots, strength class 12.9

Steel, tempered, rolled thread.

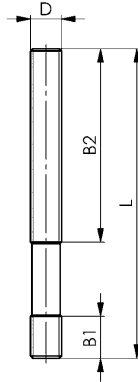

Order no.	D x L	B1	B2	Packaging Unit	Weight [g]
82123	M12x 80	15	50	50	55
89193	M12x100	15	63	25	70
89250	M12x125	15	75	25	90
89276	M12x160	15	100	25	113
82180	M16x 80	19	50	25	105
82263	M16x100	19	63	25	130
85571	M16x125	19	75	25	160
87734	M16x160	19	100	25	218
87759	M16x200	19	125	-	280
87791	M16x250	19	160	-	325
87668	M20x125	27	70	-	255
87684	M20x160	27	100	-	330
87700	M20x200	27	125	-	410
87742	M20x250	27	160	-	510
87833	M20x315	27	190	-	640
87692	M20x500	27	315	-	1020
88286	M24x160	35	100	-	470
88930	M24x200	35	125	50	580
89094	M24x250	35	160	-	730
89136	M24x315	35	200	-	920
89151	M24x400	35	250	-	1160
89177	M24x500	35	315	-	1460

#### Advantage:

- higher strength class compared to IN 6379

#### Benefits of thread rolling:

- no interrupted fibre orientation
- reduced notch sensitivity
- very good roughness values on the thread flanks and in the base radius

#### Recommendations



DIN 6331, page 108



DIN 6340, page 113

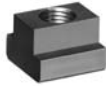

DIN 508, page 104

CAD



## No. 6379I

### Studs with hexagon socket, strength class 12.9

Steel, tempered, rolled thread.

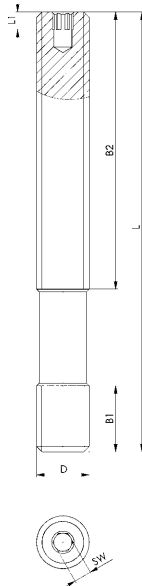

Order no.	D x L	Strength class	B1	B2	L1	SW	Weight [g]
381954	M12x100	12.9	15	63	4	4	70
381913	M12x125	12.9	15	75	4	4	90
381970	M12x160	12.9	15	100	4	4	113
381996	M16x125	12.9	19	75	4	4	160
381939	M16x160	12.9	19	100	4	4	218
382010	M16x200	12.9	19	125	4	4	280
382028	M20x160	12.9	27	100	5	5	330
382036	M20x200	12.9	27	125	5	5	410
382044	M20x250	12.9	27	160	5	5	510
382051	M24x200	12.9	35	125	5	5	580
382069	M24x250	12.9	35	160	5	5	730

#### Application:

- For use in all areas of cutting and non-cutting production
- particularly suitable for use on injection moulding machines and presses

#### Advantage:

- fast loosening or tightening by additional hexagon socket
- variable and fast adjustment options at a distance from the workpiece
- higher strength class compared to IN 6379

#### Benefits of thread rolling:

- no interrupted fibre orientation
- reduced notch sensitivity
- very good roughness values on the thread flanks and in the base radius

#### Note:

The nuts DIN 6330B, strength class 10 and washers DIN 6340 must be used in combination with this threaded pin.

#### Recommendations



ISO 2936C

CAD



Subject to technical alterations.

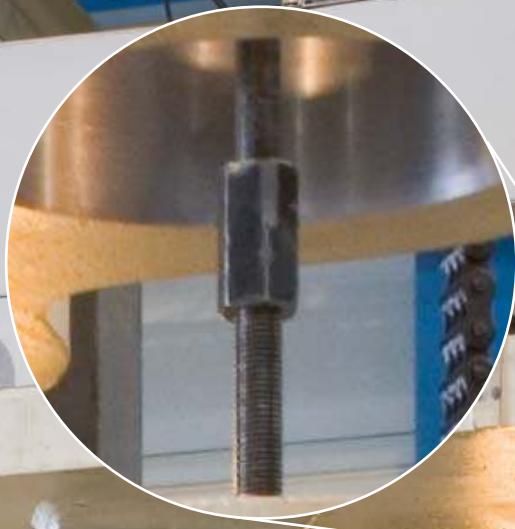

+K

## DIN 508

### Nuts for T-slots (T-nuts)

tempered, grade 10.

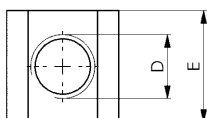
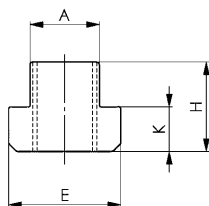

Order no.	D x Slot	Test force [kN]	A	E	H	K	Packaging Unit	Weight [g]
80002	M 5x 6	11,4	5,7	10	8	4	50	4
80010	M 6x 8	16,0	7,7	13	10	6	100	9
80028	M 8x10	29,0	9,7	15	12	6	100	12
140301	M 8x12*	29,0	11,7	18	14	7	50	22
140327	M 8x14*	29,0	13,7	22	16	8	50	41
153460	M 8x16*	29,0	15,7	25	18	9	25	50
153478	M 8x18*	29,0	17,7	28	20	10	25	91
80036	M10x12	46,0	11,7	18	14	7	50	22
80234	M10x14*	46,0	13,7	22	16	8	50	37
80366	M10x16*	46,0	15,7	25	18	9	25	60
81265	M10x18*	46,0	17,7	28	20	10	25	87
80044	M12x14	67,0	13,7	22	16	8	50	35
80168	M12x16*	67,0	15,7	25	18	9	25	50
158907	M12x18*	67,0	17,7	28	20	10	25	82
80051	M14x16*	-	15,7	25	18	9	25	50
80176	M14x18*	-	17,7	28	20	10	25	70
80069	M16x18	128,0	17,7	28	20	10	50	70
80184	M16x20*	128,0	19,7	32	24	12	25	110
155630	M16x22*	128,0	21,7	35	28	14	25	176
159418	M16x24*	128,0	23,7	40	32	16	10	260
159426	M16x28*	128,0	27,7	44	36	18	-	383
80077	M18x20*	-	19,7	32	24	12	25	110
80242	M18x22*	-	21,7	35	28	14	10	163
80085	M20x22	196,0	21,7	35	28	14	25	155
80192	M20x24*	196,0	23,7	40	32	16	10	235
158899	M20x28*	196,0	27,7	44	36	18	-	355
80093	M22x24*	-	23,7	40	32	16	10	220
80358	M22x28*	-	27,7	44	36	18	10	340
80101	M24x28	282,0	27,7	44	36	18	-	322
80200	M24x30*	282,0	29,7	48	38	19	-	440
80218	M24x36*	282,0	35,6	54	44	22	-	700
80119	M27x32*	-	31,6	50	40	20	-	460
80127	M30x36	448,0	35,6	54	44	22	-	590
80226	M30x42*	448,0	41,6	65	52	26	-	1150
80135	M36x42	653,0	41,6	65	52	26	-	1010
80143	M42x48	653,0	47,6	75	60	30	-	1600
80150	M48x54	653,0	53,6	85	70	34	-	2300

\* Size not included in DIN, dimensions similar to DIN

#### Note:

The full load capacity can only be achieved if the screw connection is applied over the entire length „H“ of the thread.

For test force see DIN 508

#### On request:

Special makes on request.

#### Recommendations



DIN 6379,  
page 100



DIN 6331,  
page 108



DIN 6340,  
page 113



Subject to technical alterations.

## No. 508F

### T-nuts with spring

tempered, grade 10.  
Spring: Stainless steel.

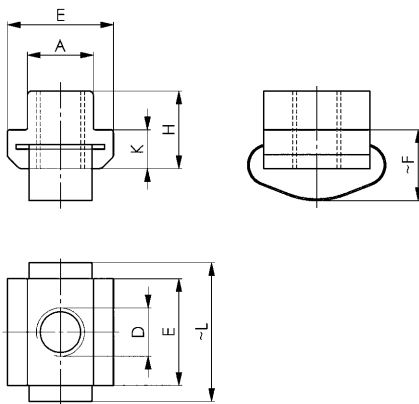

Order no.	D x Slot	Test force [kN]	A	E	F	H	K	L	Weight [g]
89730	M8x12	29	11,7	18	12,5	14	7	31	24
89748	M10x12	46	11,7	18	12,5	14	7	31	21
89763	M10x14	46	13,7	22	13,5	16	8	33	38
89771	M12x14	67	13,7	22	13,5	16	8	33	34
89839	M16x18	128	17,7	28	17,5	20	10	43	70
89904	M20x22	196	21,7	35	21,5	28	14	56	153

#### Advantage:

- stable position in the T-slot, especially in vertical position
- easy screwing of the stud, pull rod etc.
- slot cleaning effect

#### Note:

For test force see DIN 508

#### Recommendations



DIN 6379,  
page 100



DIN 6331,  
page 108



DIN 6340,  
page 113

CAD



## No. 508L

### Nuts for T-slots, extended

tempered, grade 10.

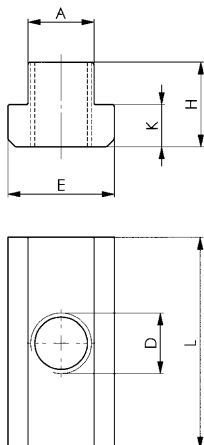

Order no.	D x Slot	Test force [kN]	A	E	H	K	L	Packaging Unit	Weight [g]
84640	M5x6	11,4	5,7	10	8	4	20	50	8
84657	M6x8	16,0	7,7	13	10	6	26	50	14
84665	M8x10	29,0	9,7	15	12	6	30	50	30
84673	M10x12	46,0	11,7	18	14	7	36	50	49
84681	M12x14	67,0	13,7	22	16	8	44	25	82
84699	M14x16	-	15,7	25	18	9	50	50	120
84707	M16x18	128,0	17,7	28	20	10	56	20	170
84715	M18x20	-	19,7	32	24	12	64	10	260
84723	M20x22	196,0	21,7	35	28	14	70	-	360
84749	M24x28	282,0	27,7	44	36	18	88	-	730
84764	M30x36	448,0	35,6	54	44	22	108	-	1390

#### Advantage:

This extended form safeguards the T-slots of precision machine tables.

#### Note:

For test force see DIN 508

#### Recommendations



DIN 6379,  
page 100



DIN 6331,  
page 108



DIN 6340,  
page 113

CAD



Subject to technical alterations.

## No. 510

### Nuts for T-slots „Rhombus“

Tempered.

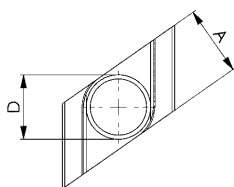
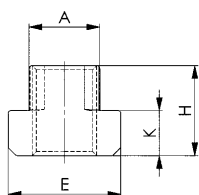

Order no.	D x Slot	Test force [kN]	A	E	H	K	Packaging Unit	Weight [g]
85993	M 6x8	10	7,7	13	10	6	50	7
87411	M 8x10	19	9,7	15	12	6	50	11
80259	M10x12	30	11,7	18	14	7	50	14
158220	M10x14	30	13,7	22	16	8	50	27
158238	M10x18	30	17,7	28	20	10	25	64
80267	M12x14	43	13,7	22	16	8	50	22
80275	M14x16	59	15,7	25	18	9	25	33
80283	M16x18	80	17,7	28	20	10	25	46
80341	M16x20	80	19,7	32	24	12	25	79
158246	M16x22	80	21,7	35	28	14	25	119
158253	M16x28	80	27,7	44	36	18	-	278
80291	M18x20	101	19,7	32	24	12	25	70
80309	M20x22	129	21,7	35	28	14	25	98
88153	M20x24	129	23,7	40	32	16	-	170
84731	M20x28	129	27,7	44	36	18	-	248
80317	M24x28	186	27,7	44	36	18	-	215
80325	M30x36	296	35,6	54	44	22	-	430
80333	M36x42	431	41,6	65	52	26	-	690

#### Application:

- additional setup of a clamping point for a fixture already clamped
- subsequent setup of a clamping point for machine table T-slots already occupied
- Insertion of the nut for „Rhombus“ T-slots from above into the T-slot and turning up to the stop in the T-slot
- To be used in conjunction with the studs DIN 6379

#### Note:

The nuts for „Rhombus“ T-slots are tempered to grade 10. Owing to the reduced contact surface in the T-slot, the load capacity is less than with the comparable sizes of DIN 508. The screw connection must be applied over the entire length of thread „H“.

#### Recommendations



DIN 6379, page 100



DIN 6331, page 108



DIN 6340, page 113



## No. 508R

### Blanks for T-nuts

Tempered steel 0.35-0.45 % C, unhardened, bare.

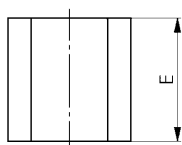
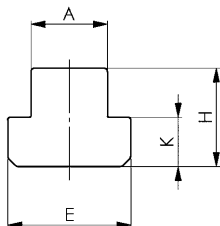

Order no.	Slot	A	E	H	K	Packaging Unit	Weight [g]
84509	6	5,7	10	8	4	25	4
84517	8	7,7	13	10	6	25	10
84525	10	9,7	15	12	6	50	16
84533	12	11,7	18	14	7	50	27
84541	14	13,7	22	16	8	50	50
84558	16	15,7	25	18	9	25	70
84566	18	17,7	28	20	10	25	95
84574	20	19,7	32	24	12	25	150
84582	22	21,7	35	28	14	25	210
84590	24	23,7	40	32	16	10	300
84608	28	27,7	44	36	18	-	430
84483	32	31,7	50	40	20	-	630
84632	36	35,6	54	44	22	-	800
84491	42	41,6	65	52	26	-	1400

#### Note:

Heat treatment for achieving grade 10 according to 22-32 HRC. Harden: 880°C for 45 minutes, quench in oil at 75°C. Temper: 550°C for 2 hours. This blank can be used to economically produce „Nuts for T-slots“ with customised thread.

#### Recommendations



DIN 6379, page 100



DIN 6331, page 108



DIN 6340, page 113



Subject to technical alterations.

## DIN 6330B

### Hexagon nuts (1.5 d high)

Steel, tempered, strength class 10.  
Can be used for conical socket DIN 6319D or DIN 6319G.  
Can be used with the flat end for washers DIN 6340.

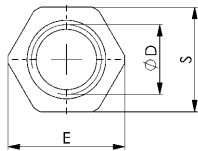
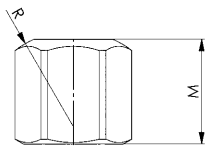

Order no.	Size D	E	M	R	S	Packaging Unit	Weight [g]
82362	M6	11,05	9	9	10	100	5
82370	M8	14,38	12	12	13	100	9
82354	M10	17,77	15	15	16	50	14
82388	M10 *	18,90	15	15	17 *	50	20
82347	M12	20,03	18	17	18	50	20
82396	M12 *	21,10	18	17	19 *	50	28
82321	M14 *	23,36	21	20	21	50	34
82404	M14 *	24,49	21	20	22 *	50	45
82412	M16	26,75	24	22	24	50	58
82420	M18 *	30,14	27	24	27	25	83
82438	M20	33,53	30	27	30	25	110
82339	M22 *	37,72	33	30	34	10	185
82446	M22 *	35,72	33	30	32 *	10	130
82453	M24	39,98	36	32	36	10	195
82461	M27 *	45,63	40	36	41	-	280
82479	M30	51,28	45	41	46	-	405
82487	M36	61,31	54	50	55	-	715
82495	M42	72,61	63	58	65	-	1170
82503	M48	83,91	72	67	75	-	1800

\* Size not included in DIN, dimensions similar to DIN

#### Recommendations



DIN 6379,  
page 100



DIN 787,  
page 94



DIN 6340,  
page 113

CAD



## No. 6334

### Elongation nuts (3.0 d high)

Steel, tempered, strength class 10.

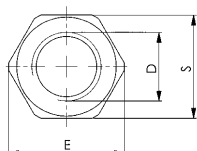
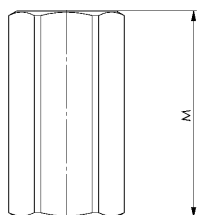

Order no.	Size D	E	M	S	Packaging Unit	Weight [g]
82651	M6	11,05	18	10	100	8
82669	M8	14,38	24	13	50	19
82271	M10	17,77	30	16	25	30
82677	M10	18,90	30	17	25	42
82289	M12	20,03	36	18	25	48
82685	M12	21,10	36	19	25	64
82297	M14	23,36	42	21	25	73
82693	M14	24,49	42	22	25	95
82701	M16	26,75	48	24	25	120
82719	M18	30,14	54	27	20	170
82727	M20	33,53	60	30	10	240
82305	M22	37,72	66	34	10	390
82735	M22	35,72	66	32	10	280
82743	M24	39,98	72	36	-	400
82750	M27	45,63	81	41	-	600
82768	M30	51,28	90	46	-	850
82776	M36	61,31	108	55	-	1470
82784	M42	72,61	126	65	-	2340
82792	M48	83,91	144	75	-	3600

#### Application:

The extension nut no. 6334 is used to connect T-slot bolts DIN 787 with studs DIN 6379. Through-drive of thread is not possible. For function and safety both screws should match half the length of nut on either side. Minimum depth is 1,2 x D

CAD



Subject to technical alterations.

## DIN 6331

### Hexagonal nuts with collar (1.5 d high)

Steel, turned, tempered, strength class 10.

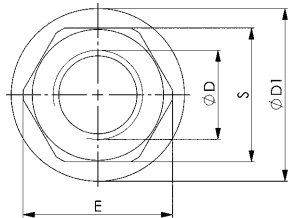
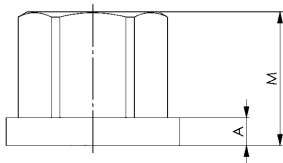

Order no.	Size D	A	D1	E	M	S	Packaging Unit	Weight [g]
82529	M6	3,0	14	11,05	9	10	50	6
82537	M8	3,5	18	14,38	12	13	50	12
82222	M10	4,0	22	17,77	15	16	50	21
82545	M10 *	4,0	22	18,90	15	17 *	50	25
82230	M12	4,0	25	20,03	18	18	25	30
82552	M12 *	4,0	25	21,10	18	19 *	25	36
82248	M14 *	4,5	28	23,36	21	21	25	43
82560	M14 *	4,5	28	24,49	21	22 *	25	51
82578	M16	5,0	31	26,75	24	24	25	70
82586	M18 *	5,0	34	30,14	27	27	25	95
82594	M20	6,0	37	33,53	30	30	25	130
82255	M22 *	6,0	40	37,72	33	34	10	200
82602	M22 *	6,0	40	35,72	33	32 *	10	160
82610	M24	6,0	45	39,98	36	36	10	230
82628	M27	8,0	50	45,63	40	41	-	320
82636	M30	8,0	58	51,28	45	46	-	470
82644	M36	10,0	68	61,31	54	55	-	800
82511	M42	12,0	80	72,61	63	65	-	1340
82800	M48	14,0	92	83,91	72	75	-	2040

\* Size not included in DIN, dimensions similar to DIN

#### Advantage:

- very good roughness values on the clamping surface by means of lathed surface

#### Recommendations



DIN 6379,  
page 100



DIN 787,  
page 94

CAD



## DIN 6331

### Hexagonal nuts with collar (1.5 d high)

Steel, forged, tempered, strength class 10.

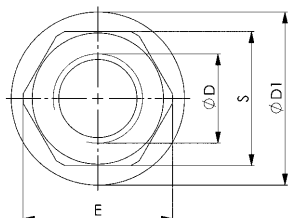
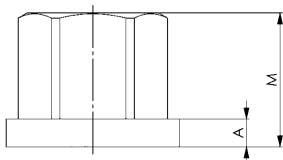

Order no.	Size D	A	D1	E	M	S	Packaging Unit	Weight [g]
82198	M6	3,0	14	11,05	9	10	50	6
82115	M8	3,5	18	14,38	12	13	50	12
82214	M10	4,0	22	17,77	15	16	50	21
82107	M12	4,0	25	20,03	18	18	25	30
82149	M16	5,0	31	26,75	24	24	25	70
82206	M18 *	5,0	34	30,14	27	27	25	95
82156	M20	6,0	37	33,53	30	30	25	130
82164	M24	6,0	45	39,98	36	36	10	230
82313	M27	8,0	50	45,63	40	41	-	320
82172	M30	8,0	58	51,28	45	46	-	470

\* Size not included in DIN, dimensions similar to DIN

#### Recommendations



DIN 6379,  
page 100



DIN 787,  
page 94

CAD



Subject to technical alterations.

## No. 6332S

### Quick-action clamping nut without collar

Steel, galvanised, strength class 6.

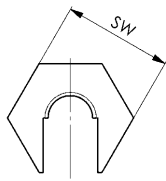
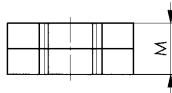

#### Recommendations



DIN 6379,  
page 100



DIN 787,  
page 94

Order no.	Size	Test force [kN]	SW	M	Weight [g]
88146	M 6	13,5	16	9,0	10
88534	M 8	24,9	19	10,5	15
88559	M10	39,4	22	12,5	23
88567	M12	59,0	27	15,0	44
88575	M16	109,9	34	16,0	68
88583	M20	176,4	41	22,0	85

#### Application:

Slide quick-action clamping nut directly over screw thread up to clamping point and then lock it. If the quick-action clamping nut base is firmly in contact at the clamping point, then the head can be locked with the base by means of a 1/4 to 1/2 turn.

#### Advantage:

- time-saving in the case of long and damaged studding
- easy assembly/disassembly at narrow and non-visible places
- no seizing up on the thread by external influences
- no impairment by soiling such as paint residues or rust

#### Note:

For test force see EN ISO 898-2

CAD



## DIN 894

### Open-ended spanner, single-ended

Special steel forging, jaws machined, angle of jaws 15°, hardened and phosphated.



Order no.	SW	Thread metric	B	L	T	Packaging unit	Weight [g]
53579	8	5	19	100	4	10	15
53595	10	6	22	105	5	10	22
53611	12	-	26	125	5	10	31
53629	13	8	29	130	5	10	37
53645	17	10*	36	160	6	10	81
53520	18	12	39	160	7	10	89
53652	19	12*	40	175	7	10	98
53660	22	14*	46	195	8	10	139
53678	24	16	50	215	9	10	165
53686	27	18	56	235	10	10	210
53694	30	20	62	260	11	10	290
53702	32	22*	67	275	12	10	333
53710	36	24	74	300	13	10	500

\* Size not according to DIN ISO 272.

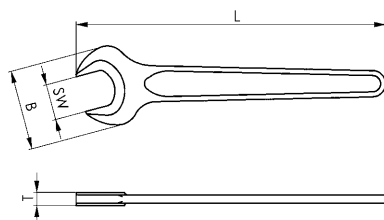

No. 6333S

## AMF-TWINNUT nut - without collar

with hard detent.  
Bright, strength class 10.

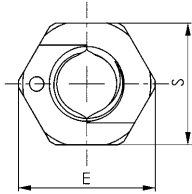
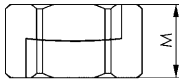

Order no.	Size	E	M	S	Weight [g]
381772	M6	11	6	10	3
381780	M8	14	8	13	6
381798	M10	19	10	17	14
381806	M12	21	12	19	20
381814	M16	27	16	24	39
381822	M20	33	20	30	75
381830	M24	40	24	36	131

### Application:

Separable bolt nuts for quick-mounting applications. It can be simply pushed over long or damaged studding. Nut halves are undetachable through the separation block, even in the swivelled out condition.

### Advantage:

- Time saved with long and damaged studding
- Overcomes studding that is corroded, damaged at the thread and even bent up to approx. 20°
- Compact design., extremely easy to handle
- Fast installation and disassembly using standard tools
- Retention as solid nuts of the same size with strength class 10.

### Note:

After they are pushed together, a 1/4 to 1/2 turn suffices for locking.

### On request:

Other materials and special sizes on request.

### Recommendations



DIN 6379,  
page 100



DIN 787,  
page 94

### Easy mounting of the TWINNUT collar nut:



### Easy removal of the TWINNUT collar nut:



Subject to technical alterations.

## No. 6333SB

### AMF-TWINNUT nut - with collar

with hard detent.  
Bright, strength class 10.

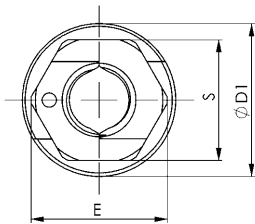
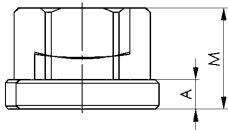

Order no.	Size	A	D1	E	M	S	Weight [g]
381848	M6	3,0	14	11	9	10	5
381855	M8	3,5	18	14	12	13	12
381863	M10	4,0	22	19	14	17	24
381871	M12	4,0	25	21	16	19	33
381889	M16	5,0	31	27	21	24	62
381897	M20	6,0	37	33	26	30	114
381905	M24	6,0	45	40	30	36	188

#### Application:

Separable bolt nuts for quick-mounting applications. It can be simply pushed over long or damaged studding. Nut halves are undetachable through the separation block, even in the swivelled out condition.

#### Advantage:

- Time saved with long and damaged studding
- Overcomes studding that is corroded, damaged at the thread and even bent up to approx. 20°
- Compact design, extremely easy to handle
- Fast installation and disassembly using standard tools
- Retention as solid nuts of the same size with strength class 10.

#### Note:

After they are pushed together, a 1/4 to 1/2 turn suffices for locking.

#### On request:

Other materials and special sizes on request.

#### Recommendations



DIN 6379,  
page 100



DIN 787,  
page 94



## No. 6333

### Mounting key

Aluminium.

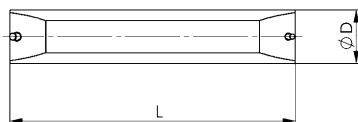
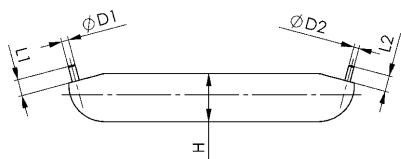

Order no.	D	D1	D2	H	L	L1	Weight [g]
381921	15	2	1,5	13,3	80	5	36

#### Application:

- for opening the AMF-TWINNUT nuts
- can be used for all nut sizes

## DIN 6319C

### Spherical seat washer

Case hardened.

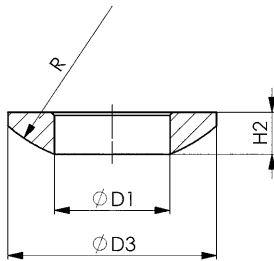

Order no.	Size	D1	D3	H2	R	Packaging Unit	Weight [g]
81828	M6	6,4	12	2,3	9	100	1,0
81737	M8	8,4	17	3,2	12	100	2,5
81745	M10	10,5	21	4,0	15	100	5,0
81752	M12	13	24	4,6	17	100	7,0
81760	M14	15	28	5,0	22	50	10
81778	M16	17	30	5,3	22	100	12
81786	M20	21	36	6,3	27	50	23
81794	M24	25	44	8,2	32	25	42
81802	M30	31	56	11,2	41	-	87
81810	M36	37	68	14,0	50	-	184
81836	M42	43	78	17,0	58	-	297
81844	M48	50	92	21,0	67	-	525

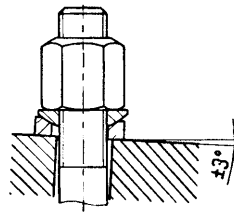

#### Recommendations



DIN 6330B, page 107

## DIN 6319D

### Dished washer

Case hardened. Designed for screw solidity in compliance with 8.8. Limited for use on flat closed ring areas (not allowed for elongated holes, we recommend DIN 6319G for these).

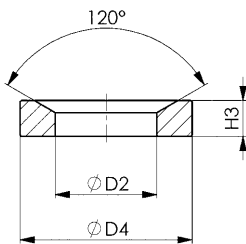

Order no.	Size	max.* [kN]	D2	D4	H3	Packaging Unit	Weight [g]
81950	M6	9	7,1	12	2,8	100	1,5
81869	M8	17	9,6	17	3,5	100	4,0
81877	M10	26	12,0	21	4,2	100	6,5
81885	M12	38	14,2	24	5,0	100	10
81893	M14	53	16,5	28	5,6	50	18
81901	M16	73	19,0	30	6,2	50	19
81919	M20	117	23,2	36	7,5	25	32
81927	M24	168	28,0	44	9,5	25	63
81935	M30	269	35,0	56	12	-	133
81943	M36	394	42,0	68	15	-	236
81968	M42	542	49,0	78	18	-	365
81976	M48	714	56,0	92	22	-	641

\* max. transmittable static screw force.

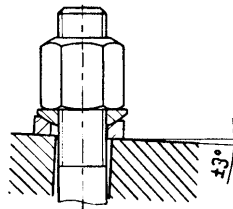

#### Recommendations



DIN 6330B, page 107

## No. 6319D

### Conical sockets, tempered

made of C45. Designed for screw solidity in compliance with 12.9. Limited for use on flat closed ring areas (not allowed for elongated holes, we recommend DIN 6319G for these).

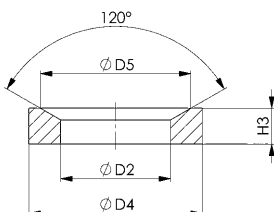

Order no.	Size	D2	D4	D5	H3	F max. [kN]	Packaging Unit	Weight [g]
87171	M12	14,2	24	20	5,0	38	100	10
87197	M16	19,0	30	26	6,2	73	50	19
87239	M20	23,2	36	31	7,5	117	25	32
87254	M24	28,0	44	37	9,5	168	25	63

#### Note:

F max. = max. transferable static screw force.

Subject to technical alterations.

## DIN 6319G

### Dished washer

Steel, tempered to 350 + 80 HV30.  
Suitable for clamping over slots with clamps.

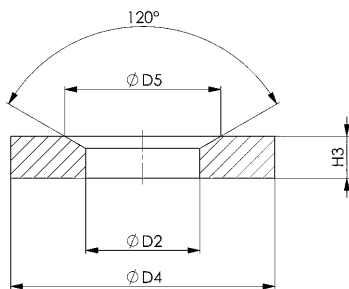

Order no.	Size	D2	D4	D5	H3	F max. [kN]	Packaging Unit	Weight [g]
82073	M6	7,1	17	11,0	4	9	25	5,5
81984	M8	9,6	24	14,5	5	17	100	13
81992	M10	12,0	30	18,5	5	26	100	19
82008	M12	14,2	36	20,0	6	38	100	32
82016	M14	16,5	40	24,8	6	53	50	48
82024	M16	19,0	44	26,0	7	73	50	56
82032	M20	23,2	50	31,0	8	117	25	94
82040	M24	28,0	60	37,0	10	168	10	169
82057	M30	35,0	68	49,0	12	269	-	230
82065	M36 *	42,0	80	60,0	12	394	-	350
82081	M42 *	49,0	100	70,0	15	-	-	640
82099	M48 *	56,0	108	82,0	17	-	-	830

\* Size not included in DIN, dimensions similar to DIN

### Note:

F max. = max. transferable static screw force.

### Recommendations



DIN 6330B,  
page 107



DIN 6319C,  
page 112

## DIN 6340

### Washers for clamping tools

Steel, tempered (350 + 80 HV30)

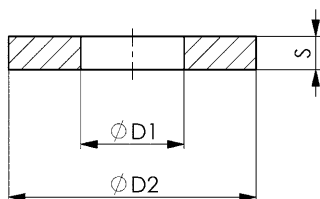

Order no.	Size	Size inch	D1	D2	S	Packaging Unit	Weight [g]
82818	M6	1/4	6,4	17	3	100	5
82826	M8	5/16	8,4	23	4	100	10
82834	M10	3/8	10,5	28	4	100	16
82842	M12	1/2	13	35	5	100	35
82859	M14 *	-	15	40	5	50	40
82867	M16	5/8	17	45	6	50	60
82875	M18 *	-	19	45	6	50	60
82883	M20	3/4	21	50	6	50	73
82891	M22 *	7/8	23	50	6	25	72
82909	M24	7/8	25	60	8	20	170
82917	M27 *	1 1/16	28	68	10	-	210
82925	M30	1 1/8, 1 3/16	31	68	10	-	230
82933	M36 *	1 1/4, 1 3/8	38	80	10	-	350
82941	M42 *	1 1/2	44	100	15	-	670
82958	M48 *	1 3/4	50	108	17	-	920

\* Size not included in DIN, dimensions similar to DIN

### Recommendations



DIN 6379,  
page 100



DIN 787,  
page 94

Subject to technical alterations.

## No. 6530

### Boxed set of assorted clamping elements

With deep clamping jaw no. 6490 and screw compound no. 6339. The clamping tool assortment boxes are designed for machine tools with T-slot tables and contain all the elements required for the fast clamping of tools, fixtures and workpieces. They are produced from tempered steel according to DIN or factory standards. Screw parts strength class 8 and/or 10. In a sturdy and high-quality wooden box with removable folding lid.



Order no.	Slot	No. 6500E Pcs.xSize	No. 6314Z Pcs.xSize	DIN 787 Pcs.xLength	DIN 6379 Pcs. xLength	DIN 6330B	DIN 6319G	No. 6334	No. 6490* Pcs.xSize	No. 6485 Pcs.xSize	No. 3113A Pcs.xSize	No. 6339	L x W x H	Weight [Kg]
83584	M10x10	4x1, 4x2, 2x3	4x 11x80	2x40, 4x63, 4x100	4x80	6x	6x	4x	4x12	-	1x 16x16	1x	355x270x47	9,2
83592	M12x12	4x2, 4x3	4x 14x100	2x50, 4x80, 4x125	4x100	6x	6x	4x	4x12	-	1x 18x18	1x	460x330x50	14,3
83600	M12x14	4x2, 4x3	4x 14x100	2x50, 4x80, 4x125	4x100	6x	6x	4x	4x14	1x 14-20	1x 18x18	1x	460x330x50	14,6
83691	M14x16	4x2, 4x3	2x 14x100, 4x 14x160	2x63,4x100,4x160	4x125	6x	6x	4x	4x16	1x 14-20	1x 22x22	1x	510x415x50	18,5
83618	M16x16	4x2, 4x3	4x 18x125	2x63,4x100,4x160	4x125	6x	6x	4x	4x16	1x 14-20	1x 24x24	1x	510x415x50	21,5
83626	M16x18	4x2, 4x3	4x 18x125	2x63,4x100,4x160	4x125	6x	6x	4x	4x18	1x 14-20	1x 24x24	1x	510x415x50	21,5

\* The low height clamping jaws no. 6490 are complete sets with T-nuts DIN 508, screws ISO 4762 and two hexagon keys ISO 2936. Single items available.

## No. 6531

### Boxed set of assorted clamping elements

With sprung clamp holder no. 6342 and screw compound no. 6339.

The clamping tool assortment boxes are designed for machine tools with T-slot tables and contain all the elements required for the fast clamping of tools, fixtures and workpieces. They are produced from tempered steel according to DIN or factory standards. Screw parts strength class 8 and/or 10. In a sturdy and high-quality wooden box with removable folding lid.



Order no.	Slot	No. 6500E Pcs.xSize	No. 6314Z Pcs.xSize	DIN 787 Pcs.xLength	DIN 6379 Pcs. xLength	DIN 508	DIN 6330B	DIN 6319G	No. 6485 Pcs.xSize	No. 3113A Pcs.xSize	DIN 6342 Pcs.xSize	No. 6334	No. 6339	L x W x H	Weight [Kg]
83808	M10x10	4x1, 4x2, 2x3	4x 11x80	4x63, 4x100	4x80	-	6x	6x	-	1x 16x16	4x1	4x	1x	350x225x47	6,5
83816	M12x12	4x2, 4x3	4x 14x100	4x80, 4x125	4x100	-	4x	6x	-	1x 18x18	4x2	4x	1x	359x333x57	11,0
83824	M12x14	4x2, 4x3	4x 14x100	4x80, 4x125	4x100	-	4x	6x	1x 14-20	1x 18x18	4x2	4x	1x	359x333x57	11,0
83832	M16x16	4x2, 4x3	4x 18x125	4x100, 4x160	4x125	-	4x	6x	1x 14-20	1x 24x24	4x3	4x	1x	390x415x55	16,5
83840	M16x18	4x2, 4x3	4x 18x125	4x100, 4x160	4x125	-	4x	6x	1x 14-20	1x 24x24	4x3	4x	1x	390x415x55	16,5
83642	M20x22	4x2, 4x3	4x 22x160	4x125, 4x200	4x125	-	6x	6x	1x 22-32	1x 30x30	4x4	4x	1x	480x528x60	24,5

Single items available.

Subject to technical alterations.

## No. 6520

### T-bolt set

In a sturdy and high-quality wooden box with removable folding lid. All parts tempered, strength class 8 or 10.



Order no.	Slot	DIN 787 Pcs.xLength	DIN 6379 Pcs.xLength	DIN 508	DIN 6330B	No. 6334	DIN 6319C+G	DIN 6340	L x W x H	Weight [Kg]
82982	M10x10	2x40, 4x63, 4x100	4x50, 4x80, 4x200	1)	4x	4x	4x	4x	254x188x32	2,0
82990	M12x12	2x50, 4x80, 4x125	4x63, 4x100, 4x200	1)	4x	4x	4x	4x	278x234x36	3,2
83006	M12x14	2x50, 4x80	4x63, 4x100, 4x125, 4x200	4x	4x	4x	4x	4x	278x234x36	3,5
83014	M14x16	2x63, 4x100	4x63, 4x100, 4x160, 4x250	4x	4x	4x	4x	4x	317x239x44	5,4
83030	M16x18	2x63, 4x100	4x80, 4x125, 4x160, 4x250	4x	4x	4x	4x	4x	339x294x48	7,4
83055	M20x22	2x80, 4x125	4x80, 4x125, 4x200, 4x315	4x	4x	4x	4x	4x	358x342x56	13,5
83063	M24x28	2x100, 4x160	4x100, 4x160, 4x250, 4x400	4x	4x	4x	4x	4x	444x409x72	23,6

1) = T-nuts DIN 508 not suitable for this size.

2) = M18x20, included instead DIN 787 are 4 studs DIN 6379x125 mm and 2x80 mm, with DIN 508 T-nuts and DIN 6340 washers each. Single items available.

## No. 6532

### Basic sortiment

All parts are produced from tempered steel according to DIN or factory standards, screw parts tempered to strength class 8 or 10. Ideal for tool making, manufacturing and training facilities.



Order no.	Size	Clamping force [kN]	max. clamping height using 2 clamps [mm]	max. clamping height using 4 clamps [mm]	No. 6314Z Pcs.xSize	No. 6500E Pcs.xSize	DIN 787 Pcs.xLength	DIN 6379 Pcs.xLength	DIN 6330B	DIN 6340	No. 6334	Weight [Kg]
83899	M12x14	20	165	70	2x14x100,2x14x160	4x2, 4x3	2x50,4x80,4x125	2x100	6x	6x	2x	10,0
83915	M14x16	28	195	100	2x14x100,2x14x160	4x2, 4x3	2x63,4x100,4x160	2x100, 2x160	6x	6x	2x	11,1
83907	M16x18	40	205	130	2x18x125,2x18x200	4x2, 4x3	2x63,4x80,4x160	2x200, 4x125	6x	6x	4x	15,2

## No. 6470

### Trolley for clamping equipment

without clamping equipment and without holders.  
Rugged steel housing, storage compartments designed with rubber mats. 2 rollers + 2 castors with locking brake.



Order no.	Load [Kg]	Height [cm]	Width [cm]	Depth [cm]	Weight [Kg]
74252	400	126	123	80	100

#### Advantage:

- Mobile = quickly ready when needed at the workplace
- Tidy = convenient, space-saving and always readily available
- Individual equipment configurations possible through variable arrangement of holders

#### Note:

Holders for clamps (No. 6470H-2) and clamping bolts (No. 6470H-1) can be selected as required.

## No. 6470-Mxx

### Trolley for clamping equipment with basic set of clamping equipment

incl. clamping equipment tool cart no. 6470.



Order no.	Size	Holder no. 6470H-01	Holder no. 6470H-02	Weight [Kg]
		[St.]	[St.]	
72520	M16	5	4	257,0
73270	M20	5	4	277,0
74674	M24	5	4	304,0
74880	M30	7	4	512,5

## Design:

Product	Order no. 72520 (Size M16)			Order no. 73270 (Size M20)			Order no. 74674 (Size M24)			Order no. 74880 (Size M30)		
	Order no.	Size	Pc.	Order no.	Size	Pc.	Order no.	Size	Pc.	Order no.	Size	Pc.
DIN 6379	81422	M16x125	6	84988	M20x125	6	85563	M24x125	6	85068	M30x125	6
	85498	M16x200	6	81513	M20x200	6	85514	M24x200	6	81612	M30x200	6
	85548	M16x315	6	84996	M20x315	6	86009	M24x315	6	81620	M30x315	6
	85472	M16x500	6	85001	M20x500	6	86025	M24x500	6	81638	M30x500	6
										81646	M30x700	6
										81661	M30x1000	6
DIN 6331	82578	M16	30	82594	M20	30	82610	M24	30	82636	M30	30
DIN 6340	82867	M16	30	82883	M20	30	82909	M24	30	82925	M30	30
DIN 6314	70060	18x160	4	70086	22x200	4	70102	26x250	4	70128	33x315	4
DIN 6315B	70524	18x160	4	70557	22x200	4	70581	26x250	4	70623	33x315	4
	70532	18x200	4	70573	22x315	4	70607	26x315	4	70631	33x400	4
	70540	18x250	4	70425	22x500	4	70433	26x500	4	70441	33x600	4
No. 6334	82701	M16	10	82727	M20	10	82743	M24	10	82768	M30	10
No. 6400	72413	100	4									
	72439	210	4									
No. 6435S	72637	300	4	72637	300	4	72637	300	4	72645	460	4
	72645	460	4	72645	460	4	72645	460	4	72652	750	4
										72660	1250	4
No. 508L	84707	M16x18	10	84723	M20x22	10	84749	M24x28	10	84764	M30x36	10
No. 510	80283	M16x18	10	88153	M20x24	10	80317	M24x28	10	80325	M30x36	10

Subject to technical alterations.

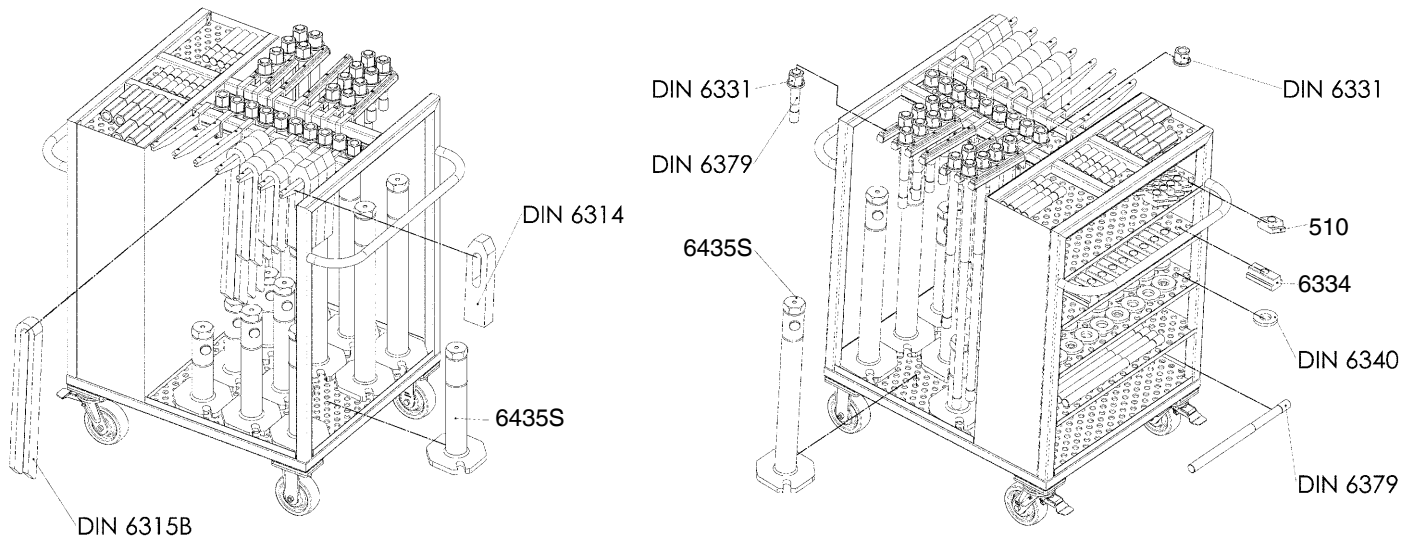

**No. 6470H-1**  
**Holder for clamping bolts**

Order no.	L [mm]	B [mm]	B1 [mm]	H [mm]	Weight [g]
74187	342	20	25	85	866

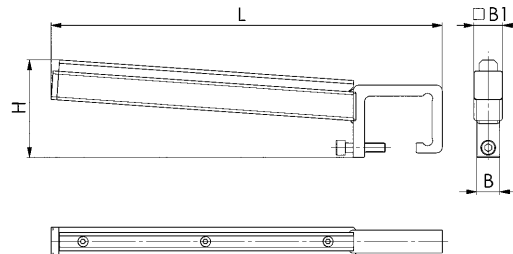

**No. 6470H-2**  
**Holder for clamps**

Order no.	L [mm]	B [mm]	B1 [mm]	H [mm]	Weight [g]
74203	342	20	16	76	870

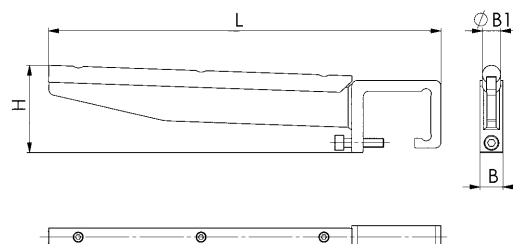

Subject to technical alterations.

## No. 6535

### Set of assorted plastic clamping elements

depending on size consisting of:  
 4 x support blocks with stepped teeth  
 2 x clamping jaws with stepped teeth  
 2 x clamping jaws double  
 10 x knurled nuts with hexagonal  
 high-strength plastic PBT, red.  
 Studs: Aluminium anodised.

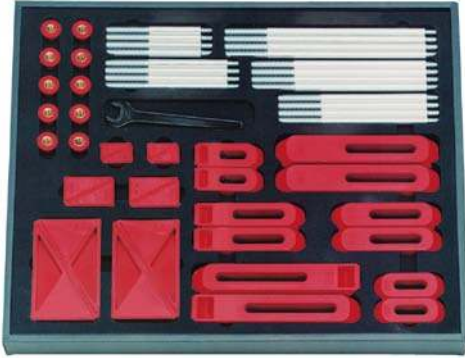

Order no.	Size	D1 x M	B1	St. x LS	L x W x H	Weight [g]
83071	06	M6 x M8	10	4x100, 4x125, 4x150, 4x175, 4x200	440x370x50	1700
83105	08	M8 x M8	40	4x100, 4x125, 4x150, 4x175, 4x200	440x370x50	1740
83089	10	M10 x M8	20	4x100, 4x125, 4x150, 4x175, 4x200	440x370x50	1770

#### Application:

Most suitable for 3D-coordinate measuring machines, engraving and E.D.M. machine application and any light duty clamping. The possible clamping force (up to 500 N), depending on the actual leverage, can be achieved by manual tightening of knurled nut, while its hexagon section allows release through use of open jaw wrench.

#### Advantage:

- The weight is only 1/4 compared with aluminium and 1/10 compared with steel elements.
- anticorrosive against hand sweat
- very easy to handle
- no damage to surface plate, supporting table or workpiece
- suitable for multi-combination.

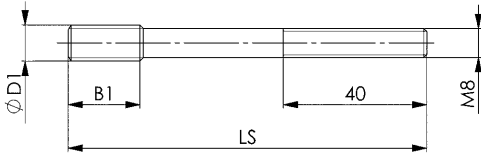

#### Recommendations



No. 6530,  
page 114



No. 6531,  
page 114



No. 6520,  
page 115

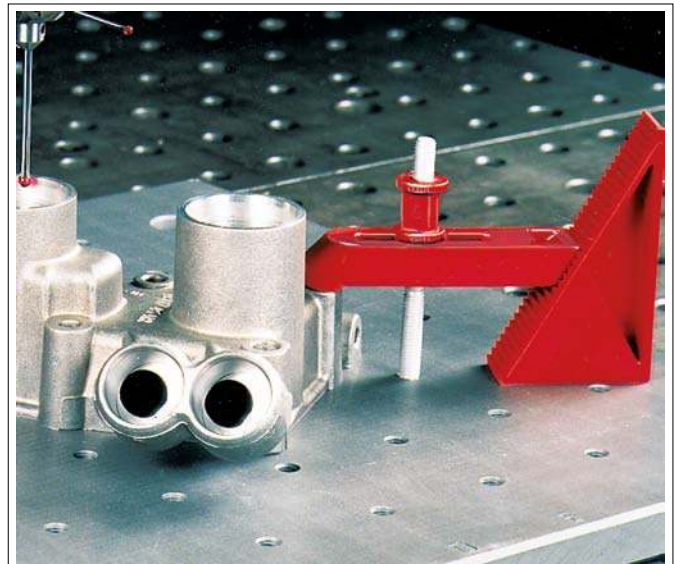
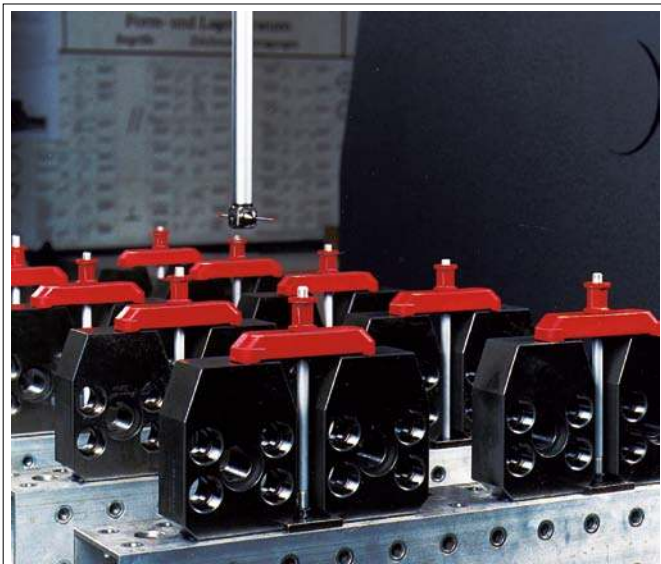

Subject to technical alterations.

## No. 6339

### Heavy duty thread paste



Order no.	Temperature range	Contents	Weight
		[ml]	[g]
86686	-25 - + 125°C	75	75

#### Application:

For lubricating screw connections in clamping fixtures. Especially when aggressive coolants are used. Unlubricated (dry) screw connections are subjected to high friction forces (clamping force reduction) and rapid wear when tightened securely often. Thanks to its optimal lubricity, AMF screw compound increases the achievable clamping force and protects the material (longer service life).

#### Features:

The paste, based on mineral fat, has a synergetic acting combination of highly active white solid lubricants. It is resistant to heat and wash off. (Washouttest according DIN 51807, part 2; loss of lubricant after 1 h/37.8°C = 1.4%).

## No. 6342

### Spring type clamp support

with brass locking screw

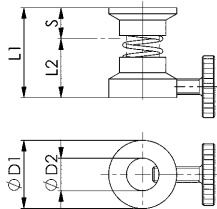

Order no.	Size	D1	D2	L1	L2	Travel of spring S	for clamping screw	Weight [g]
75952	1	22	10,5	30	22	8	M8-M10	41
75960	2	26	14,5	32	22	10	M12-M14	55
75978	3	32	18,5	38	26	12	M16-M18	89
75986	4	38	22,5	40	28	12	M20-M22	133
75994	5	45	27,5	44	32	12	M24-M27	177

The spring type clamp support holds the clamp while the work piece is removed and loaded, ensuring fast and safe clamping sequence.

#### Recommendations



DIN 6379, page 100



DIN 787, page 94

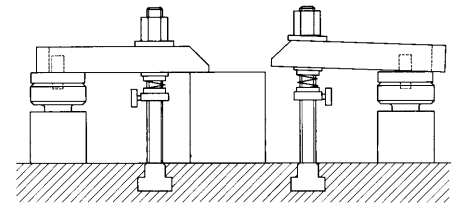
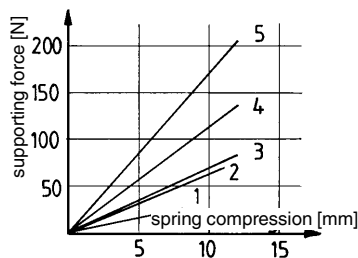

## No. 6485

### T-slot scraper

Steel, zinc-plated.



Order no.	Size	Slot	B1	L1	L	Packaging Unit	Weight [g]
72892	14-20	14-20	22,5	8,5	142	100	105
72900	22-32	22-32	35,0	14,5	184	50	170
72918	36-54	35-54	54,0	23,0	260	-	525

#### Note:

Size 14-20 without 2k hand grip.

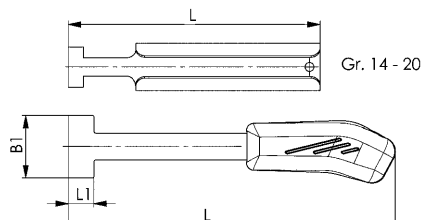

Subject to technical alterations.

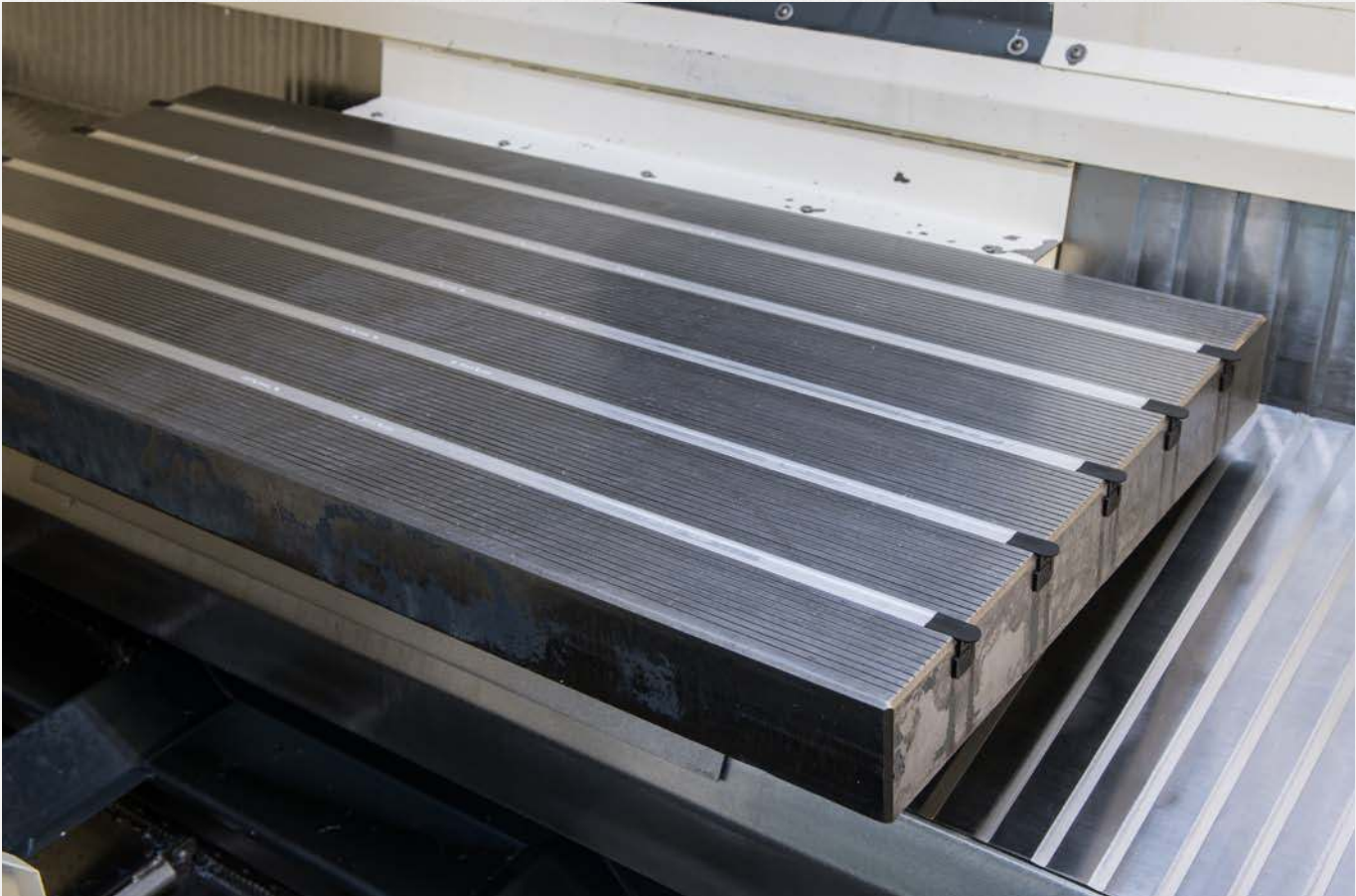

Subject to technical alterations.

## No. 6486AO

### T-slot side cover

Recyclable TPE plastic, RAL2008 orange.  
Packaging unit: 10 each/size



Order no.	Slot	A	E	H	K	L	L1	L2	Packaging unit	Weight [g]
565405	14	14	23,0	14,5	15,5	23	30	8	10	5
565401	16	16	26,5	16,5	18,5	26	33	9	10	7
565402	18	18	30,0	18,5	20,0	30	37	10	10	9
565403	22	22	37,0	22,5	24,5	35	42	12	10	14
565404	28	28	46,0	28,5	29,5	44	54	15	10	28

### Application:

In addition to our cover strips for T-slots 6486, these **new, lateral covers for T-slots** also protect the machine slot from chips and soiling. This is especially advantageous for T-slot tables of a 5-axis processing machine.

### Advantage:

- 100% recyclable plastic
- Holes and bevels permit unhindered coolant flow
- Grip possibility for pulling out of the T-slot
- The flexible cover compensates for all slot tolerances in accordance with DIN650
- Use in all machine table T-slots
- Labelled with size, fast assignment possible

## No. 6486AS

### T-slot side cover

Recyclable TPE plastic, RAL9017 black.  
Packaging unit: 10 each/size



Order no.	Slot	A	E	H	K	L	L1	L2	Packaging unit	Weight [g]
565165	14	14	23,0	14,5	15,5	23	30	8	10	5
565320	16	16	26,5	16,5	18,5	26	33	9	10	7
565321	18	18	30,0	18,5	20,0	30	37	10	10	9
565322	22	22	37,0	22,5	24,5	35	42	12	10	14
565323	28	28	46,0	28,5	29,5	44	54	15	10	28

### Application:

In addition to our cover strips for T-slots 6486, these **new, lateral covers for T-slots** also protect the machine slot from chips and soiling. This is especially advantageous for T-slot tables of a 5-axis processing machine.

### Advantage:

- 100% recyclable plastic
- Holes and bevels permit unhindered coolant flow
- Grip possibility for pulling out of the T-slot
- The flexible cover compensates for all slot tolerances in accordance with DIN650
- Use in all machine table T-slots
- Labelled with size, fast assignment possible

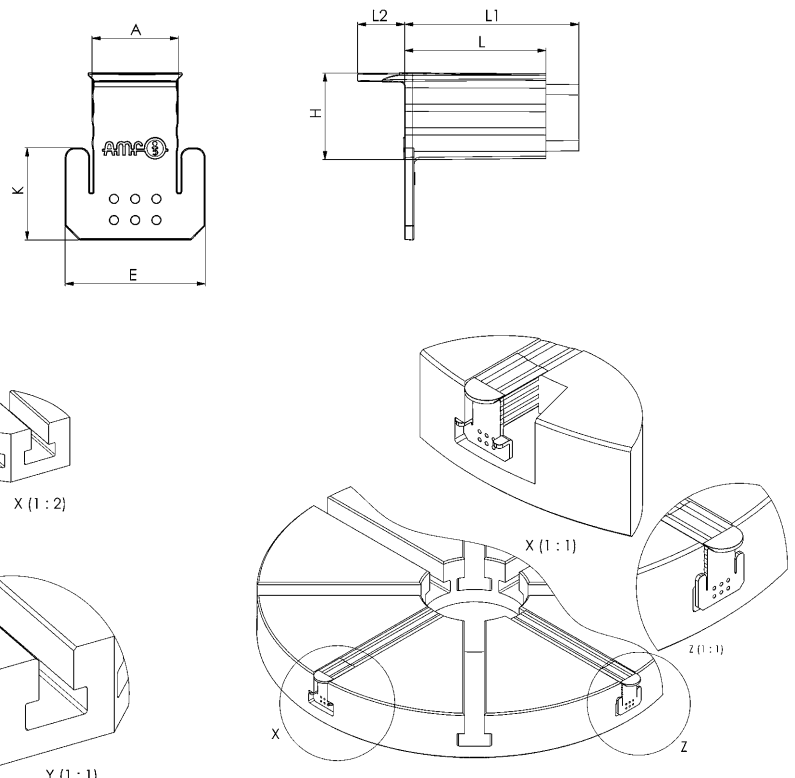

Subject to technical alterations.

## No. 6486

### T-slot cover

Made of aluminium profile.  
Cutting to the desired length is easily done with a fine saw blade.



Order no.	Size	Slot	A	B	H	L	Weight [g]
71449	12x1000	12	12,0	13,0	10,5	1000	88
71456	14x1000	14	14,0	15,5	11,5	1000	100
71464	16x1000	16	16,0	17,5	14,0	1000	120
71472	18x1000	18	18,0	19,5	15,0	1000	135
71928	20x1000	20	20,5	21,5	16,5	1000	150
71936	22x1000	22	22,5	23,5	18,0	1000	165
71787	24x1000	24	24,5	25,5	20,0	1000	170
71944	28x1000	28	28,5	29,5	22,0	1000	200
71951	36x1000	36	36,5	38,0	22,0	1000	220
564437	42x1000	42	42,7	43,4	30,0	1000	367
571087	48x1000	48	48,7	50,0	30,0	1000	395

### Advantage:

The thorough subsequent cleaning of the slot on the machine table is no longer required. Always cover free slots by using the original AMF-T-slot cover before starting with machining. The T-slot covers can easily be removed after machining.

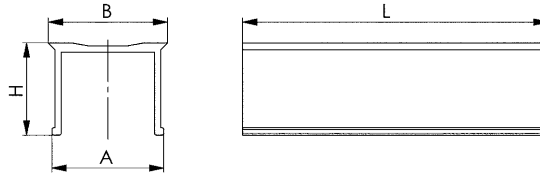

CAD



Subject to technical alterations.

The wedge action of clamping jaws is the characteristic feature of these pull down clamps. It causes the "pull down effect", which presses the workpiece against both, stop and machine table. The clamping force is resolved to its horizontal and vertical components F1 and F2. The lateral catch of jaws allows complete machining from above of top faces even for low sized workpieces without problems.

The clamp forces mentioned in the tables are achieved by using the optimal size of bolts and utilizing the respective permissible torque. Force F1 presses the workpiece against the stop, pull down force F2 is achieved with a plain face of workpiece.

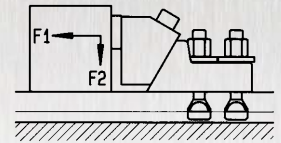

## No. 6490

### Low height clamping jaws, model „Bulle“

tempered and blued in black oxide finish. Complete with fastening bolts ISO 4762 (10.9), nuts for T-slots DIN 508 and hexagon screwdriver ISO 2936. Packed in carton in pairs.

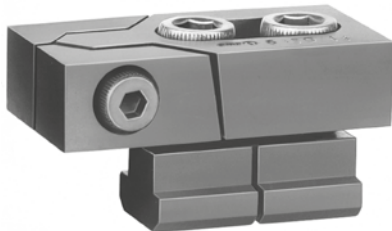

Order no.	Slot	B	C	D	H	L1	L2	L3	F1 [kN]	F2 [kN]	Weight [g]
72959	12	40	3	M10	20	80	39	26	16	0,6	1150
72967	14	40	3	M12	20	80	39	26	22	0,9	1250
72975	16	40	3	M12	20	80	39	26	22	0,9	1330
72983	16	50	4	M14	25	100	46	34	32	1,2	2340
72991	18	50	4	M16	25	100	46	34	36	1,4	2540
73007	20	50	4	M16	25	100	46	34	36	1,4	2660
73015	22	78	5	M20	30	140	65	50	36	1,4	5980
73023	24	78	5	M20	30	140	65	50	36	1,4	6330
73031	28	78	5	M24	30	140	65	50	40	1,6	7060

### Note:

The clamping forces F1 and F2 are achieved with optimum design and utilisation of the max. tightening torque of the fastening bolts.

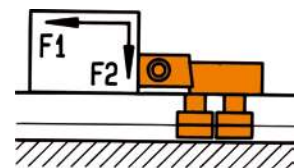
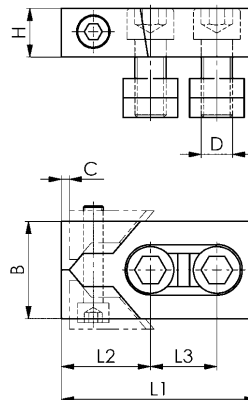

## No. 6491

### Slot stop

tempered and burnished.



Order no.	Slot	A	B	D	H	K	L1	L2	L3	Weight [g]
73817	12	11,7	18	M8	12	7	36	9,0	18	100
73825	14	13,7	22	M8	12	8	44	11,0	22	140
73833	16	15,7	25	M12	15	9	50	12,5	25	240
73841	18	17,7	28	M12	16	10	56	14,0	28	340
73858	20	19,7	32	M16	19	12	64	16,0	32	520
73866	22	21,7	35	M16	21	14	70	17,5	35	720
73874	24	23,7	40	M20	23	16	80	20,0	40	880
73882	28	27,7	44	M20	24	18	88	22,0	44	1460

### Application:

To be used for longitudinal or transversal function. The low overall height allows application with flat workpieces.

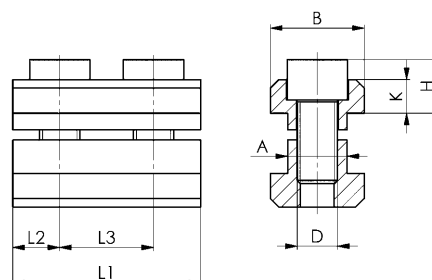

### Recommendations



No. 911LG-H100F



Subject to technical alterations.

## No. 6492

### Flat clamp, model „Mini-Bulle“

tempered and blued in black oxide finish. Complete with fastening bolts ISO 4762 (8.8), and hexagon screwdriver ISO 2936.

Packed in carton in pairs.



Order no.	Slot	H min. [mm]	H max. [mm]	B	C	H1	L	X	F1 [kN]	F2 [kN]	Weight [g]
73098	12	2,5	13,5	18	1,8	11	52	5	5,0	0,6	300
73106	14	1,5	13,5	22	1,8	11	55	5	5,5	0,7	380
73114	16	2,5	17,0	25	2,5	15	68	6	8,0	0,9	700
73122	18	1,5	16,0	28	2,5	15	71	6	9,0	1,0	830
73080	22	4,5	21,5	35	3,0	20	89	9	16	1,9	1740

### Application:

These tempered clamps are designed for extremely low workpieces. Wedge action of jaws presses the workpiece firmly and safely against the machine table. The horizontal forces are compensated by a screw related to slot size, which blocks the clamp without damage to table.

### Note:

Hmin./Hmax.: depending on the groove depth according to DIN 650.

The clamping piece can be ground by X mm. This allows lower clamping heights to be achieved.

The clamping forces F1 and F2 are achieved with optimum design and utilisation of the max. tightening torque of the fastening bolts.

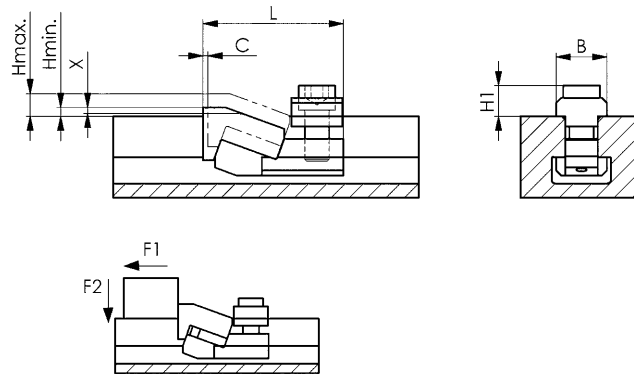

## No. 6365

### Pull-Down Clamp

Hardened steel



Order no.	Size	B	B1	H	H1	H2	Stroke	F1 [kN]	F2 [kN]	Weight [g]
88492	12	65	25	44	36	19	22	20	2	1515
79392	16	80	30	50	41	21	27	40	4	2604

### Application:

This clamping jaw must be able to run on the mounting surface.

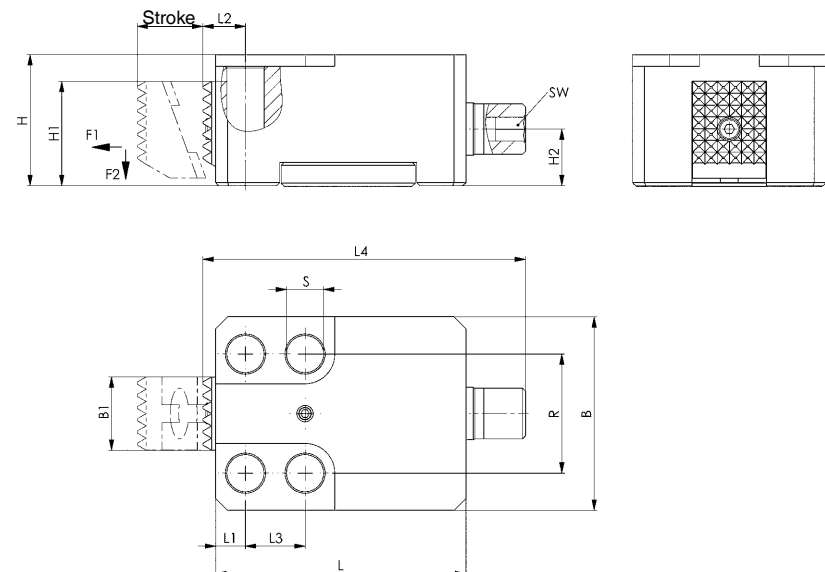

### Dimensions:

Order no.	L	L1	L2	L3	L4	R	dia. S	SW	Md [Nm]
88492	84	10	14	20	108,5	40	12,5	8	50
79392	102	15	18	25	123,0	50	16,5	10	100

### Recommendations



No. 6365G,  
page 125



No. 6365N,  
page 125

Subject to technical alterations.

## No. 6365G

### Clamping Jaws, serrated

Hardened steel



CAD

Order no.	Size	A	A1	B1	C	Weight [g]
88500	12	32,5	26	24,6	8,5	69
120360	16	37,5	31	29,8	7,5	99



#### Note:

This clamping jaw be part of standart sortiment for draw-down clamp 6365-\*\*-001.

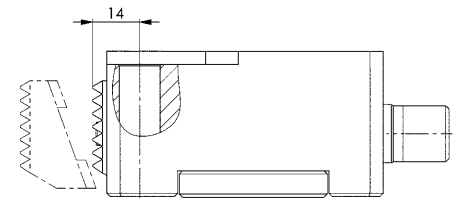
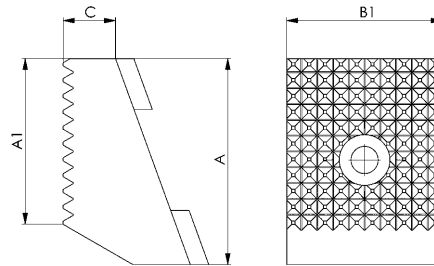

## No. 6365N

### Clamping Jaws, with ridge

hardened steel



CAD

Order no.	Size	A	A1	B1	C	R	Weight [g]
88526	12	32,5	5	24,6	13	200	74
88542	16	37,5	5	29,8	12,5	250	110



#### Application:

Suitable for pull-down clamp no. 6365. Especially suitable for workpieces with a very uneven or hard surface (castings).

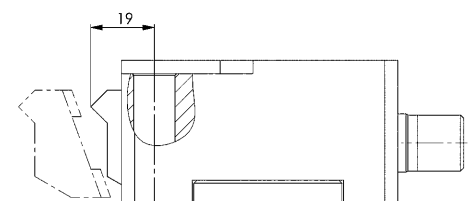
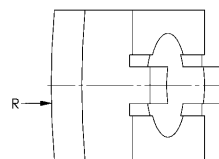
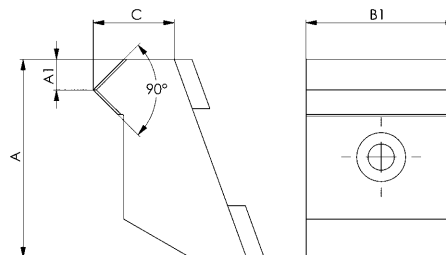

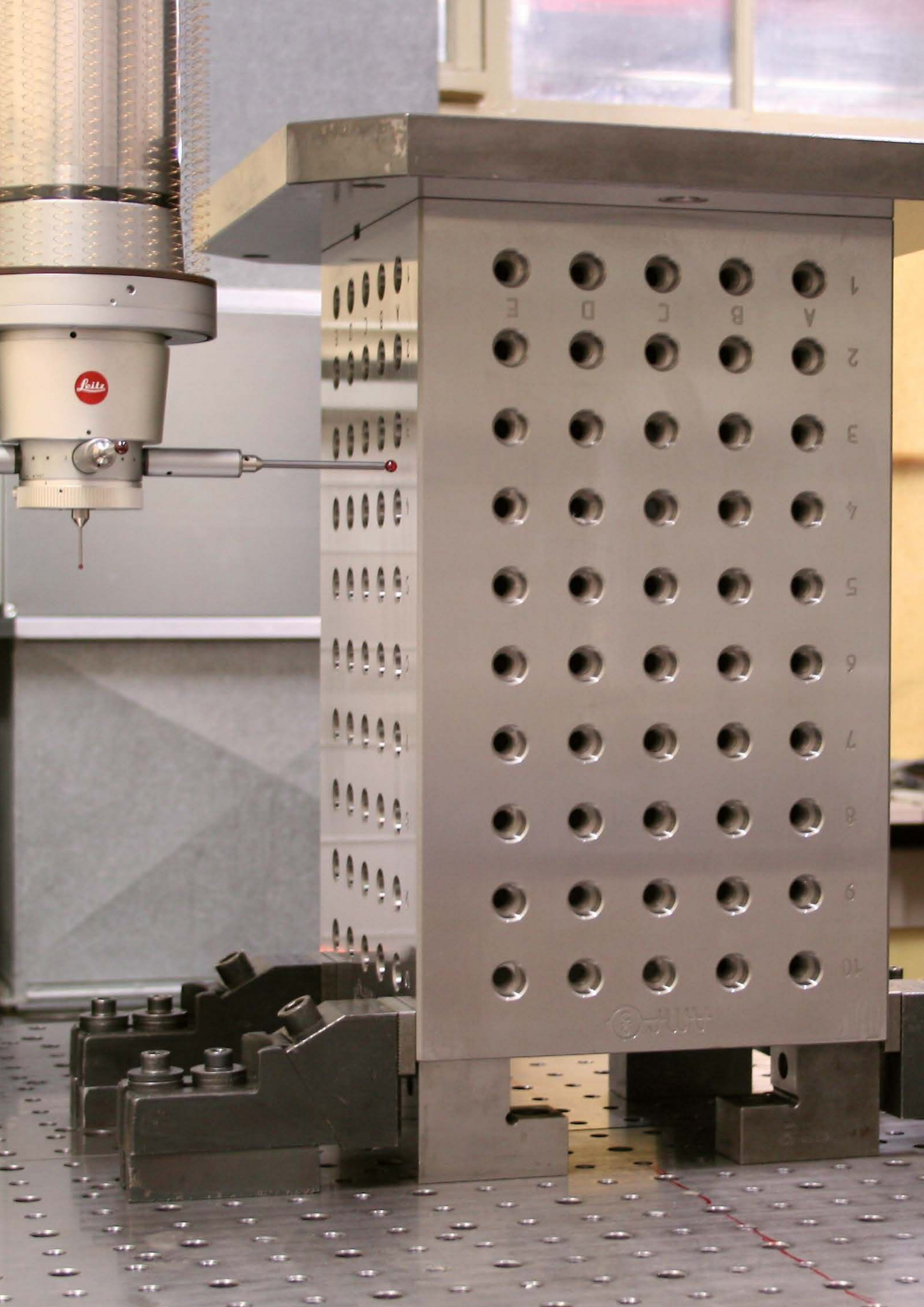

Leitz

					1
E	D	C	B	A	
					2
					3
					4
					5
					6
					7
					8
					9
					10

Leitz

No. 6494

## Low height clamping jaws, model „Maxi-Bulle“

Body: spherical casting. Jaws: tempered and burnished.  
Packing: 2 units in carton with hexagon key ISO 2936 without screws  
or bolts. Available in pairs only!



CAD



Order no.	Slot	B1	B2	C	H min. [mm]	H max. [mm]	H1	H2	L1 max.	L2	F1* [kN]	F2* [kN]	Weight:/ pair [g]
73130	10	14	40	3	50	52	20	30	115	60	6	0,2	1590
	12										10	0,4	
	14										15	0,6	
73148	16	19	50	4	60	63	25	35	150	72	20	0,8	2940
	18										28	1,1	
	20										36	1,4	
73155	22	31	80	5	75	79	30	45	205	102	38	1,5	7900
	24										38	1,5	
	28										40	1,6	
	30										40	1,6	
	32										44	1,7	
	36										44	1,7	

\* Clamping forces F1 and F2 depend on the groove width.

### Application:

The clamping jaws „Maxi-Bulle“ for work on larger heights was developed from the tried and tested Model „Bulle“ no. 6490. The wedge faces of these clamps are skillfully arranged to achieve maximum clamping force with low exertion. For fastening, 2 T-slot bolts DIN 787 for each clamping jaw, according to T-slot size in use, should be ordered separately. For lower arrangement of clamping screws use cap screws ISO 4762 with washers DIN 6340 and T-nuts 508.

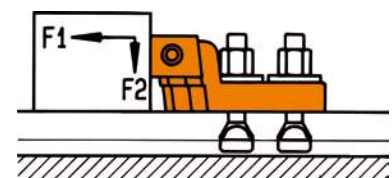
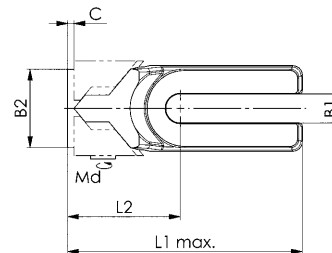

### Recommendations



No. 911LG-H100F

Subject to technical alterations.

## No. 6497F

### Solid clamping jaws, flat design

with exact prismatic guide.

Body: Tempered steel.

Clamping jaws: Case-hardened steel, case-hardened.

Reversible clamping jaws with smooth side for machined workpieces and serrated side for rough clamping surfaces.



CAD



Order no.	Slot	B1	B2	C	E	H min. [mm]	H max. [mm]	H1	H2	L1 max.	L2	L4	SW	F1* [kN]	F2* [kN]	Md [Nm]	Weight [g]
564074	10	14	40	3	8	3	33,5	20	25,4	128	82	19	13	4	0,7	11	840
	8													1,2	20		
	15													2,2	40		
562016	12	19	65	6	12	20	60	30	40	177	113	29	16	8	1,2	20	3020
	14													2,2	40		
	16													3,0	45		
	18													4,2	60		
562017	20	26	75	7,5	12	33	73	36	40	224	135	29	18	25	4,5	85	4880
	22													4,5	85		
	24													4,8	95		
	28													4,8	95		
	30													5,4	110		
562018	32	38	90	10	12	51	91,5	46	40	256	152	34	21	50	7,5	160	7715
	36																
	42																

\* Clamping forces F1 and F2 depend on the groove width

### Application:

The large clamping surface makes these solid clamping jaws suitable for laterally clamping workpieces. We recommend using two clamping studs for fastening the solid clamping jaw on the machine table. Screws for T-slots DIN 787 - two screws per clamping jaw - should be ordered separately as a fastening bolt depending on the width of the slot.

### Note:

The clamping forces F1 and F2 are achieved with optimum design and utilisation of the maximum tightening torque of the fastening bolts.

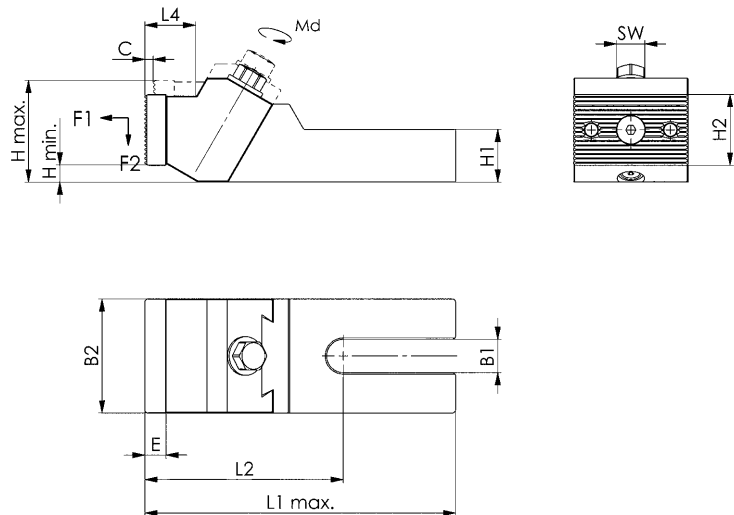

Subject to technical alterations.

## No. 6497

### Extra strong clamping jaw

High design with exact prismatic guide.  
Main body: malleable iron.

Clamping jaws: case-hardening steel, case-hardened. Reversible clamping jaws with smooth side for machined workpieces and serrated side for rough clamping surfaces.



CAD



Order no.	Slot	B1	B2	C	E	H min. [mm]	H max. [mm]	H1	H2	L1	L2	F1* [kN]	F2* [kN]	Md [Nm]	Weight [g]
73213	12	19	65	8	12	46	99	38	40	179	112,5	8	1,2	20	4037
	14											2,2	40		
	16											3,0	45		
	18											4,2	60		
73221	20	26	75	11	12	61	118	45	40	230	138,5	25	4,5	85	6688
	22											4,5	85		
	24											4,8	95		
	28											4,8	95		
	30											5,4	110		
73239	32	38	90	15	12	89	145	56	40	265	158	50	7,5	160	11031
	36														
	42														

\* Clamping forces F1 and F2 depend on the groove width.

### Application:

Due to their large clamping faces these clamping jaws are suitable for lateral clamping of high workpieces. For fastening on the machine table we recommend the use of 2 clamping screws! Related to T-slot size in use, 2 T-slot bolts DIN 787 for each clamp should be ordered separately.

### Note:

The clamping forces F1 and F2 are achieved with optimum design and utilisation of the maximum tightening torque of the fastening bolts.

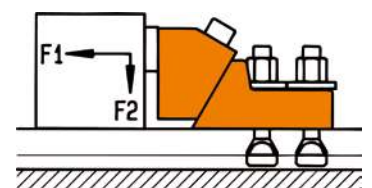
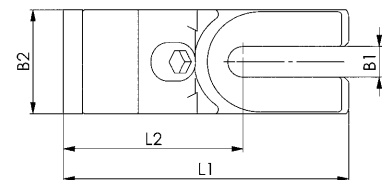
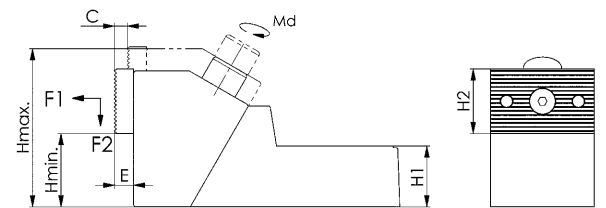

Subject to technical alterations.

## No. 6497A

### Stop, fixed

High design.  
 Body: Cast steel.  
 Clamping jaws: Case-hardening steel, case-hardened.  
 Reversible clamping jaws with smooth side for machined workpieces and serrated side for rough clamping surfaces.



CAD

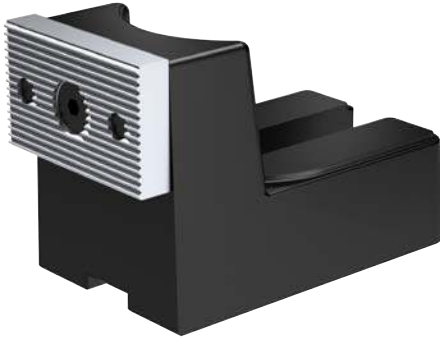

Order no.	Slot	B1	B2	E	G	H	H1	H2	K	L1	L2	Weight [g]
550509	12	19	65	12	M6	85	38	40	20	132	66,0	2857
	14											
	16											
	18											
550510	20	26	75	12	M6	100	45	40	20	177	85,5	4673
	22											
	24											
	28											
	30											
550511	32	38	90	12	M6	120	56	40	20	211	95,0	7900
	36											
	40											
	42											

### Application:

Stop for workpieces or fixtures that are clamped or fastened to the machine table using a stable clamping jaw. Depending on requirements, the clamping jaw can be rotated so that either a smooth surface or a serrated surface is available.

### Note:

Flat sliding block no. 6322A or 6322B enables the stop to be accurately positioned in the machine table groove.

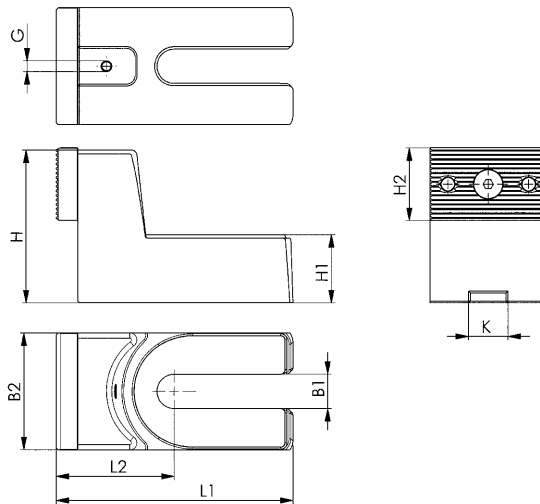
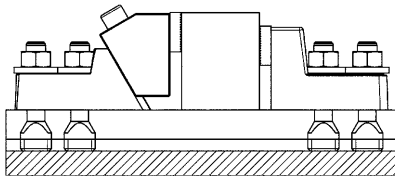

### Recommendations



No. 6497B,  
page 131

Subject to technical alterations.

## No. 6497B

### Clamping jaw

Case-hardened steel, nitrided, with fastening bolt M8



Order no.	Size	B2	D	D1	E1	E2	H2	H3	Weight [g]
550512	19	65	8,1	9	38	12	35	85	889
550513	26	75	8,1	9	38	12	45	100	1306
550514	38	90	8,1	9	38	12	50	120	1829

### Application:

Clamping jaw with serrated surface for machining of unmachined parts. Can be mounted on the stable clamping jaw or the stop.

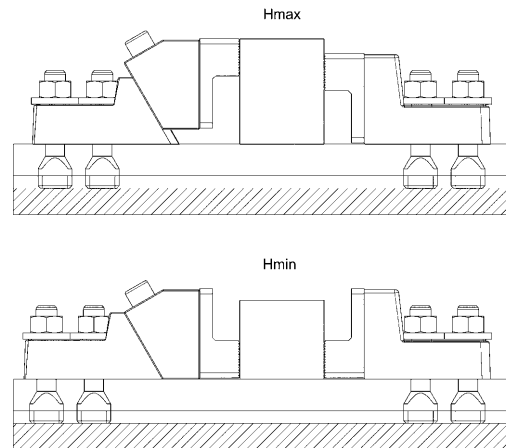
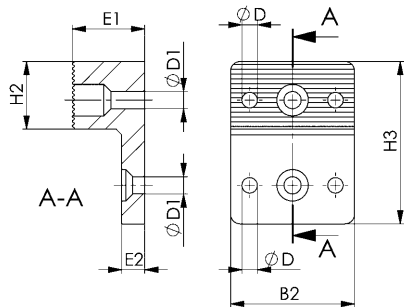

## CLAMPING WITH HORIZONTAL PRESSURE:

Fastening the horizontal clamp with screws is sufficient to hold and clamp the workpiece. The active part of the clamp consists of three elements - one rigid and two flexible parts

### A workpiece is clamped in 3 steps:

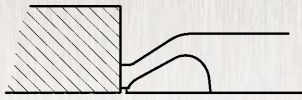

#### Contact:

The flexible clamp elements are positioned against the workpiece.



#### Hold:

The flexible clamp elements push the workpiece down until it comes into contact with the rigid clamping fingers.

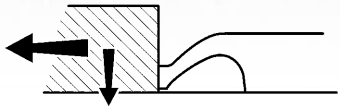

#### Clamping and positioning:

The rigid clamping finger clamps the workpiece.

Clamping force: 4,000 N  
Tightening torque: 9 Nm  
Cam stroke: 1.2 mm

Use of the cam:  
1/4-turn quick clamp

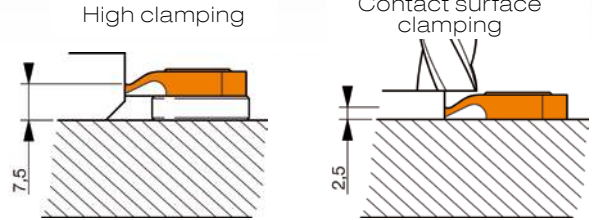
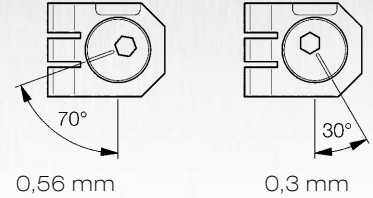

## No. 6493SP

### Clamping element, horizontal



Order no.	Clamping force [N]	Clamping height A [mm]	Stroke Eccentric [mm]	Md Eccentric [Nm]	B	C	D	E	F	Weight [g]
70680	4000	2,5	0,86	9	20	-	5	15	25	29
70698	4000	7,5	0,86	9	20	2,5	10	15	25	29

SW of the cam stroke = 4 mm

#### Application:

These hold-down clamps rotate around a camshaft that provides the clamping force. They can clamp in any direction.  
Clamping element (1 rigid stop) enables the workpiece to lie flush with the stops.

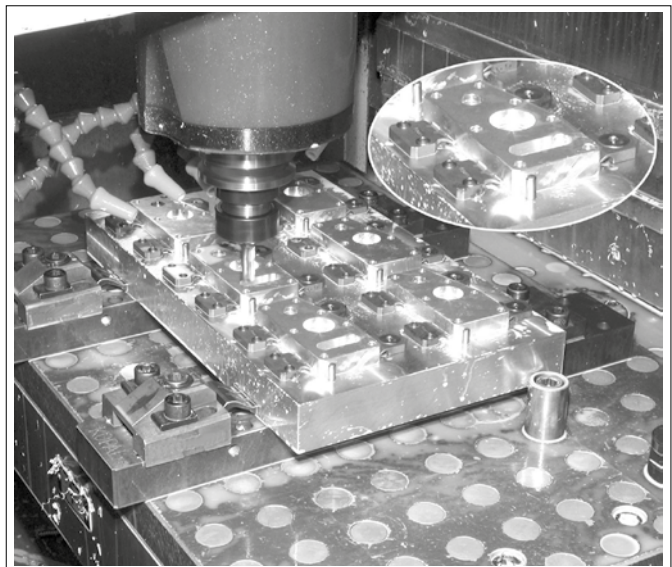
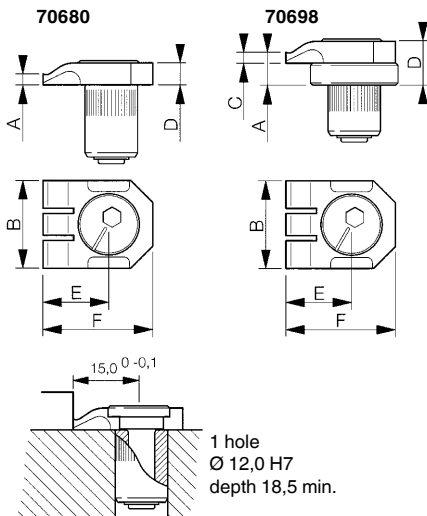
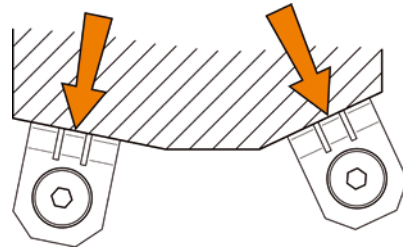

Subject to technical alterations.



## No. 6493F

### Stop, fixed

the ground, fixed stops are secured by special screws that guarantee high accuracy during installation.

Size 1 - Simple stop

Size 2 - Double stop

Order no.	Size	Clamping height A [mm]	B	C	D	E	F	G	H	Weight [g]
70987	1	2,5	20	5,0	6,5	15	22	18	25	23
70995	1	7,5	20	2,5	10,0	15	22	18	25	23
71001	2	2,5	25	5,0	6,5	15	22	18	-	23
71019	2	7,5	25	2,5	10,0	15	22	18	-	23

### Application:

Size 1 - Single stop (1 rigid stop): Two stops are required to position a workpiece along a straight line.

Size 2 - Double stop (2 rigid stops): One stop is sufficient to position a workpiece along a straight line.

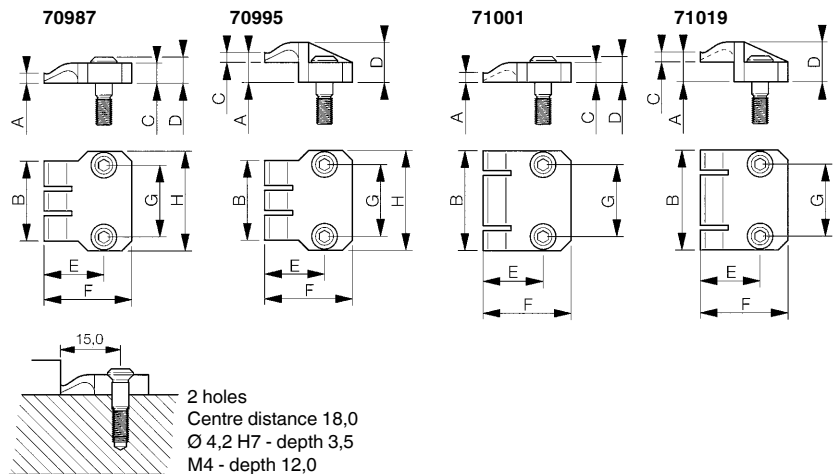
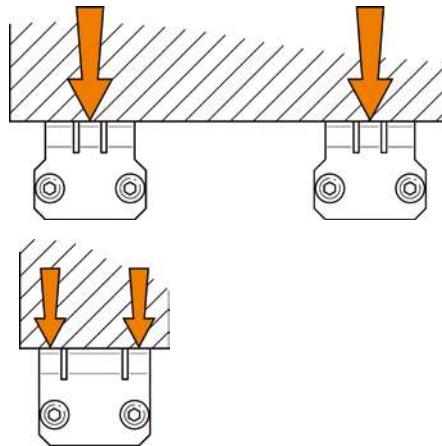

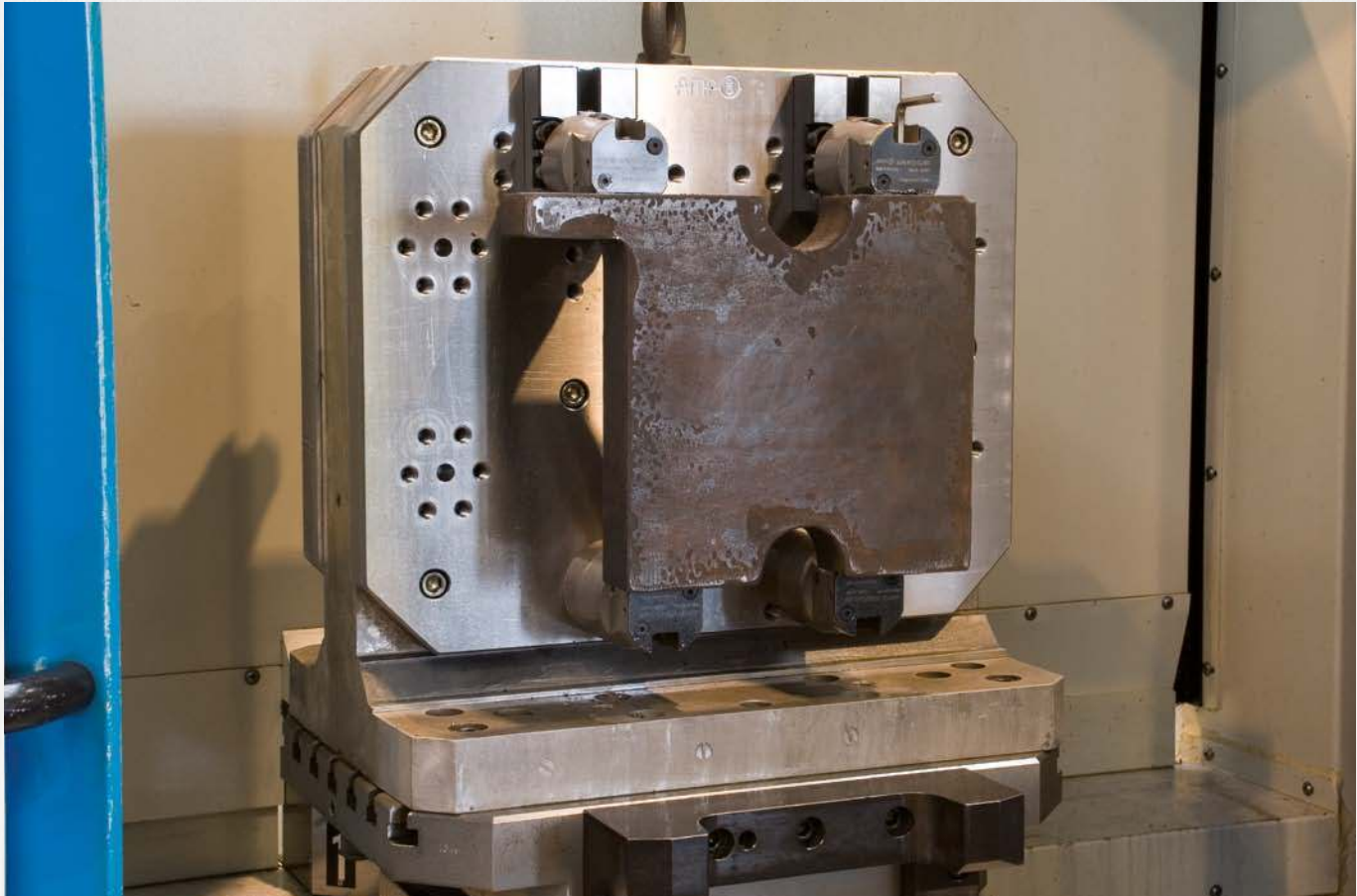

Subject to technical alterations.

## No. 6472

### Side clamp with clamping point

(without pull-down action)

Complete with fastening bolts ISO4014 (10.9) and nuts for T-slots DIN508.



Order no.	Size	G	Slot	F1 [kN]	B	H	H1	L	Stroke	Weight [g]
565651	14	M10	12	14	40,0	50,0	25,5	85	4	1395
565580	20	M12	14	20	47,5	56,0	27,5	98	6	2105
565652	30	M16	18	30	67,0	71,5	34,0	134	10	5200

### Application:

The mechanical side clamp without pull-down effect can be used as a clamping element and as a stop element.

When used in conjunction with the base plate with slot 6498FT, the side clamp can also be placed across the table slot.

### Advantage:

- Compact design
- Can be used horizontally and vertically
- Changeable set screw

### Note:

The clamping force is achieved with optimum design and utilisation of the max. tightening torque of the fastening bolts.

If larger T-nuts are used, pay attention to the screw length! Use of the flat sliding block no. 6322A enables the side clamp to be accurately positioned in the machine table groove.

Fastening takes place with a cylinder screw ISO 4762 M6 x 10.

Corresponding set screws:

- 7110DKX Set screw with ball, smooth
- 7110DFX Set screw with ball, striated

### Recommendations



No. 6472DS, page 135



No. 7110DKX-\*\*xM\*\*, page 47



No. 7110DFX-\*\*xM\*\*, page 47

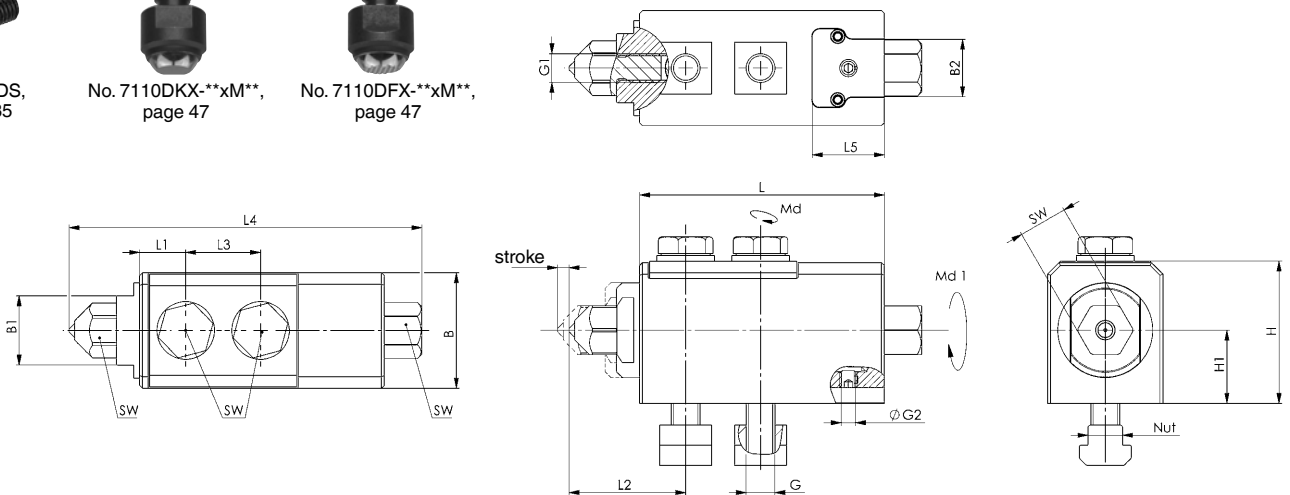

### Dimensions:

Order no.	Size	B1	B2	G1	G2	L1	L2	L3	L4	L5	SW	torque Md [Nm]	Tightening torque Md1 [Nm]
565651	14	24	20	M10	M6	16,0	40,5 - 44,5	26	122,5 - 126,5	25	17	67	45
565580	20	27	20	M12	M6	18,2	43,7 - 50,4	30	139,0 - 146,0	25	19	83	60
565652	30	36	20	M16	M6	26,5	60,5 - 70,5	36	189,5 - 199,5	32	24	205	125

## No. 6472DS

### Set screw with clamping point for side clamp

Hardened and burnished.



Order no.	Size	G [mm]	H [mm]	dia. K [mm]	L [mm]	SW [mm]	max. load static [kN]	Max. tightening torque [Nm]	Weight [g]
571389	14	M10	16,5	1,1	15,5	17	14	46	33
571391	20	M12	16,5	1,1	17,5	19	20	82	44
571392	30	M16	24,0	1,5	16,0	24	30	206	90

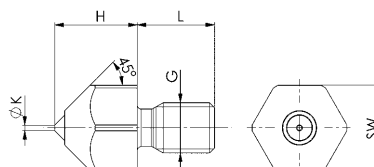

Subject to technical alterations.

## No. 6498

### Edge Clamp

complete with mounting kit. Fastened with screws of strength class 10.9.



Order no.	Size	Slot	torque Md [Nm]	H ±0,1	F1 [kN]	F2 [kN]	Weight [g]
73890	M12x14	14	75	65	12	7	1530
375501	M16x18	18	80	75	20	10	2627
374355	M20x22*	22	160	100	25	17	5996

\* Not a stock item

### Application:

The mechanical side clamp with hold-down effect can be used as a clamping element and as a fixed stop. Moving the adjusting bolt causes hook ends to clamp the workpiece. At the same time, a pull-down effect occurs on the contact surface. Attaching a lateral stop enables the workpiece to be repeatedly clamped. When used in conjunction with base plate 6498FT, the side clamp can also be placed across the table groove. In conjunction with round base plate no. 6498FR, only along the table groove.

### Advantage:

- compact dimensions
- workpiece fastened rigid and secure through pull-down effect
- plate tension increased to make holes and grooves
- lateral plate tension to completely finish surfaces without collision contour
- lateral thread enables a stop to be fastened
- can be used for horizontal and vertical applications
- reduced tooling time and tool elements cuts tooling costs
- diverse and variable applications.

### Note:

Use of a flat sliding block no. 6322A or no. 6322B enables the side clamp to be accurately positioned in the machine table groove.

### On request:

Special versions (dimension H ±0.01) are available.

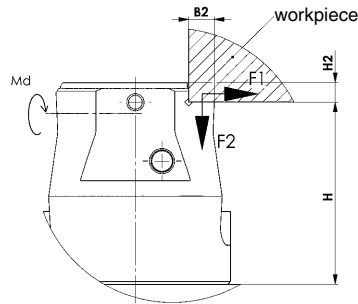
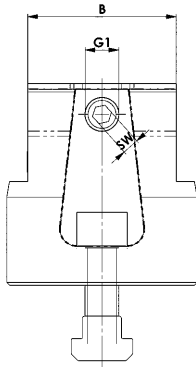
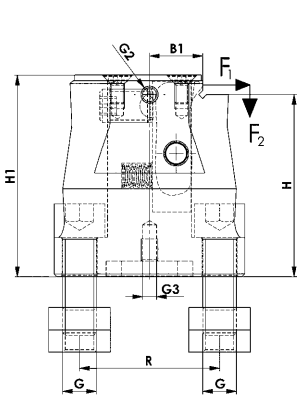
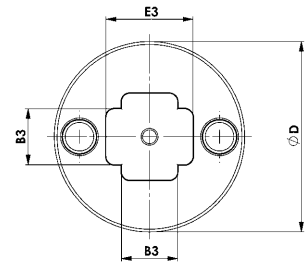

### Recommendations



No. 911LG-H100F

### Dimensions:

Order no.	Size	B	B1	B2	B3	D +2	E3	G	G1	G2	G3	H1	H2	R	SW
73890	M12x14	53	19,0	9,0	20	68	31,0	M12	M12	M6	M6	72	7	50	6
375501	M16x18	60	20,5	13,5	20	78	25,5	M16	M16	M6	M6	95	20	50	8
374355	M20x22*	88	28,5	18,0	20	108	38,0	M20	M16	M6	M6	118	18	75	10

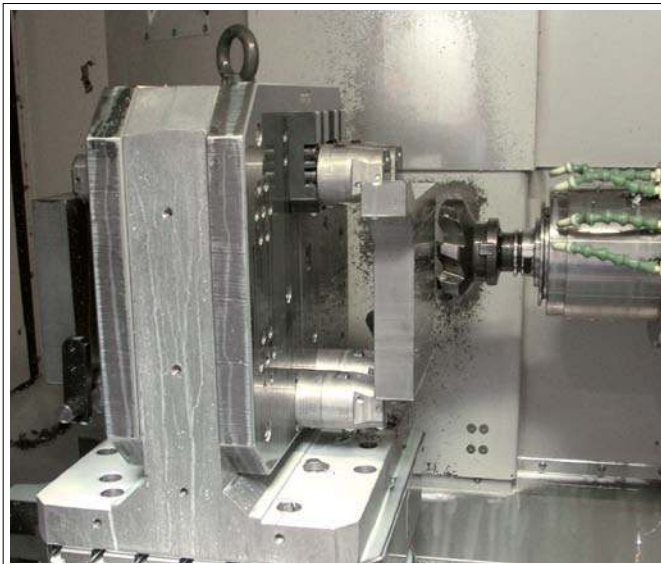

Subject to technical alterations.

## No. 6498FR

### Base plate, round

complete with fixing screws. Fastened with screws of strength class 10.9.



view from below

view from above

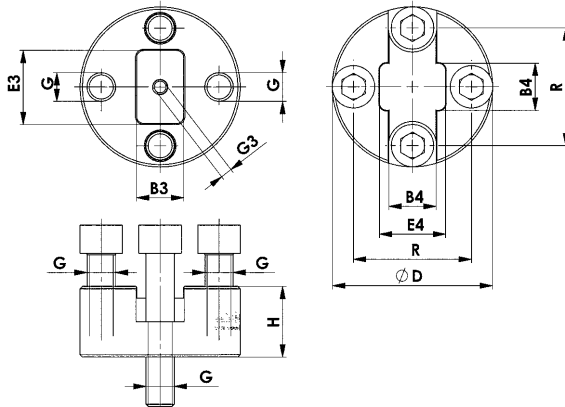

Order no.	Size	Slot	H ±0,1	B3	B4	D +2	E3	E4	G	G3	R	Weight [g]
73916	M12x14	14	30	20	18	68	31,0	28,0	M12	M6	50	930
375527	M16x18	18	50	20	18	78	25,5	25,5	M16	M6	50	1780
374371	M20x22 *	22	60	20	22	108	38,5	38,5	M20	M6	75	4680

\* Not a stock item

### Application:

Used in conjunction with side clamp no. 6498 to clamp across and along the table groove. The size M16x18 fits properly for use on the M16 grid plate.

### Advantage:

- Increase in the workpiece mounting surface.

### Note:

The flat T-nut no. 6322A-18 (71597) allows the side clamp to be connected exactly to the round base plate. The base plate can be positioned exactly on the machine table using the flat T-nuts 6322A or 6322B.

### On request:

Special versions (dimension H ±0.01) are available.

### Recommendations



No. 911LG-H100F

## No. 6498FT

### Base plate with groove

complete with mounting kit. Fastened with screws of strength class 10.9.

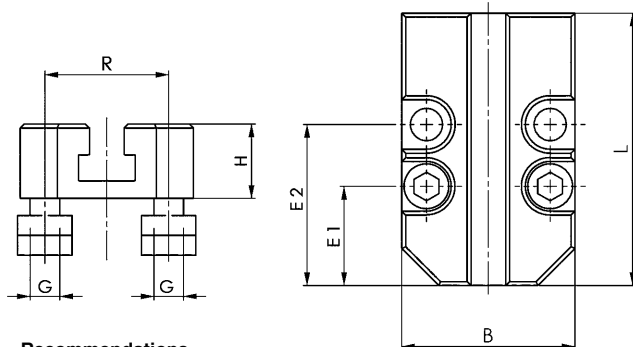

### Recommendations



No. 911LG-H100F

Order no.	Size	Slot	H ±0,1	B	E1	E2	G	L	R	Weight [g]
73908	M12x14	14	30	70	40	65	M12	110	50	1330
375543	M16x18	18	50	125	40	90	M16	130	100	4864
374397	M20x22 *	22	60	120	75	150	M20	200	85	7614

\* Not a stock item

### Application:

Used in conjunction with side clamp no. 6498 to also clamp across the table groove.

### Advantage:

- Simple use of the side clamp when clamping even across the groove  
- Increase in the workpiece mounting surface.

### On request:

Special versions (dimension H ±0.01) are available.

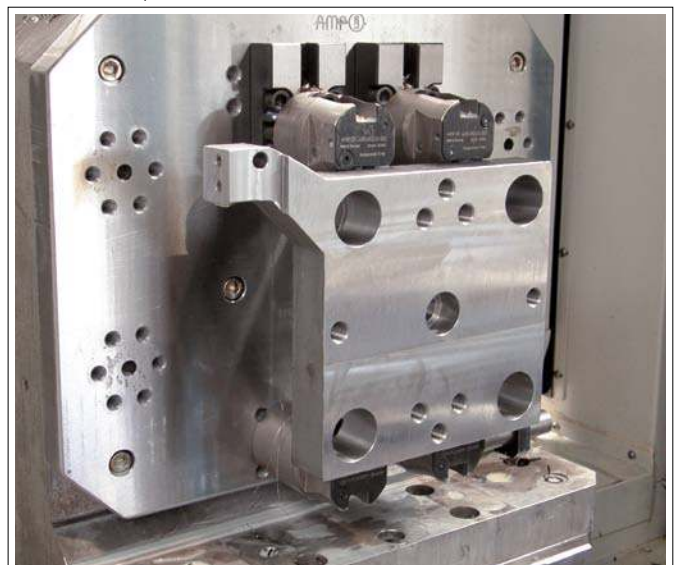

Subject to technical alterations.

## No. 6495

### T-slot clamp

complete with mounting.  
Steel, tempered and burnished.



Order no.	Size	Slot	F1 [kN]	F2 [kN]	H2	SW [mm]	Weight [g]
374140	12	14	7	3,5	10	5	91
374132	16	18	10	5,0	12	6	188
374124	20	22	16	8,0	15	8	363

### Application:

1. Slide T-slot clamp into T-slot of the machine table.
2. Position on workpiece.
3. Secure fastening bolt for machine table.
4. Actuating the clamping bolt clamps the workpiece.

### Advantage:

- For clamping of very thin workpieces
- Lateral clamping of workpieces to completely finish surfaces without interference contours
- Can be used for horizontal and vertical applications.

### Note:

- To reduce the wear on the fastening bolt, we recommend using AMF screw compound 6339. It possesses a synergistic combination of highly-effective solid lubricants and is heat-resistant and does not wash out.
- Use the associated AMF fastening bolt 6495S.

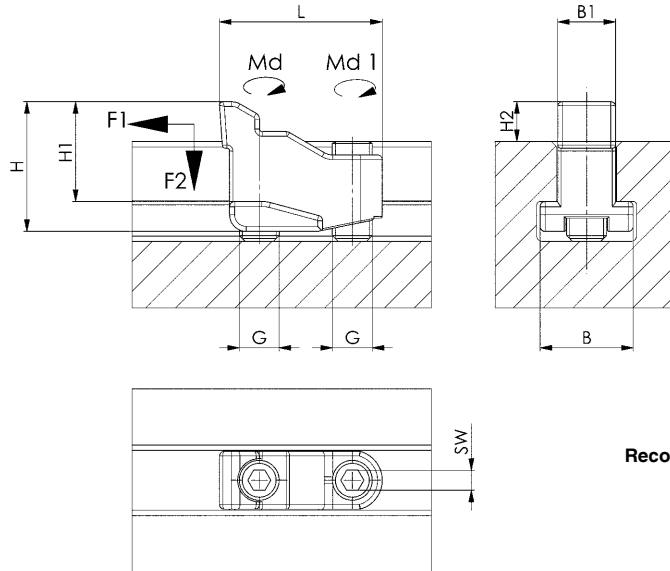

### Recommendations



No. 911LG-H100F

### Dimensions:

Order no.	Size	B	B1	G	H	H1	L	Md [Nm]	Md 1 [Nm]
374140	12	22	13,6	M10	31	24	40	18	9
374132	16	28	17,4	M12	39	30	49	32	15
374124	20	35	21,5	M16	50	37	63	75	35

CAD



## No. 6495S

### Fastening bolt for T-slot clamp

Strength class 10.9



Order no.	Size	G	L	SW [mm]	Weight [g]
79186	12	M10	25	5	14
78907	16	M12	30	6	24
77834	20	M16	40	8	59

Subject to technical alterations.

## No. 6496

### Flat clamp

Complete with mounting.  
Steel, tempered and burnished.



Order no.	Size	Slot	G	F1 [kN]	F2 [kN]	H min. [mm]	H max. [mm]	Weight [g]
374157	M12x14	14	M12	15	7,5	16	25	579
374165	M12x16	16	M12	15	7,5	16	25	600
374173	M16x18	18	M16	25	12,5	19	30	1011
374181	M16x20	20	M16	25	12,5	19	30	1055
374199	M20x22	22	M20	36	18,0	22	36	1670
374207	M20x24	24	M20	36	18,0	22	36	1705
374215	M20x28	28	M20	36	18,0	22	36	1807

### Application:

1. Slide flat clamp into T-groove of the machine table.
2. Position on workpiece.
3. Secure fastening bolts for machine table.
4. Actuating the clamping bolt clamps the workpiece.

### Advantage:

- For clamping of very thin workpieces
- Lateral clamping of workpieces to completely finish surfaces without interference contours
- Can be used for horizontal and vertical applications.

### Note:

- To reduce the wear on the fastening bolts, we recommend using AMF screw compound 6339. It possesses a synergistic combination of highly-effective solid lubricants and is heat-resistant and does not wash out.
- Use only the corresponding AMF mounting kit 6496BF.

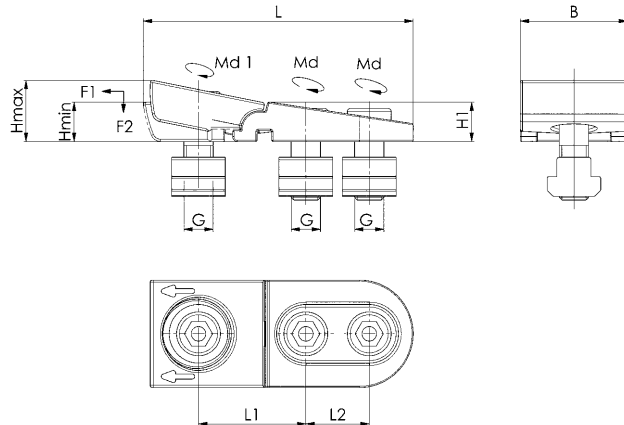

### Dimensions:

Order no.	Size	B	H1	L	L1 min.	L1 max.	L2	Md [Nm]	Md 1 [Nm]
374157	M12x14	44	16	110	45	48	26	65	52
374165	M12x16	44	16	110	45	48	26	65	52
374173	M16x18	56	19	130	50	54	33	150	120
374181	M16x20	56	19	130	50	54	33	150	120
374199	M20x22	62	22	152	58	63	41	300	240
374207	M20x24	62	22	152	58	63	41	300	240
374215	M20x28	62	22	152	58	63	41	300	240

CAD



## No. 6496BF

### Mounting kit for flat clamp

comprising 3 DIN 6912 hexagonal bolts, 3 DIN 508 T-groove nuts and 1 DIN 6319C spherical washer.



CAD



Order no.	Size	Slot	G	L	SW [mm]	Weight [g]
313379	M12x14	14	M12	30	10	49
313395	M12x16	16	M12	35	10	56
313411	M16x18	18	M16	35	14	90
313437	M16x20	20	M16	40	14	104
313452	M20x22	22	M20	45	17	177
313478	M20x24	24	M20	45	17	189
313494	M20x28	28	M20	55	17	228

### Recommendations



No. 911LG-H100F

Subject to technical alterations.

## ABOUT ALIGNING AND POSITIONING

- > **Design:** The skilfull graduation of sizes to DIN series figures allows for numerous combinations.
- > **Quality:** AMF-parallels guarantee for long life due to their high wear resistance.
- > **The right quality for any application:** Our parallel washers are available in three quality levels:

Standard ★  
 Precision ★★  
 Super-precision ★★★

AMF-parallels are used as packing blocks, stops or distance pieces on machine tools. They are indispensable for the parallel support of components in machine vices and on surface plates.

- > AMF parallel washers, stops and power clamp being used for drilling a base plate.



## DIN 6346

### Parallel supports-set

In wooden box with detachable folding lid.  
Plain parallel, fine-ground, in pairs.  
Size data on the product.  
Case-hardened.

Pair tolerance in height tp2 and width tp1 to IT 5.  
Rated dimensional tolerance in height and width to DIN ISO 2768m.  
Remaining dimensions to DIN ISO 2768m.

Geometrical graduation enables full use of the support height.  
2.5 - 25 mm over 40 different heights 2.5 - 45 mm  
4 - 32 mm over 40 different heights 4 - 57 mm  
4 - 40 mm over 40 different heights 4 - 72 mm  
8 - 50 mm over 30 different heights 8 - 90 mm  
8 - 63 mm over 40 different heights 8 - 113 mm  
20 - 100 mm over 14 different heights 20 - 180 mm.



Order no.	Size	Pair	Case L x B x H	Weight [Kg]
72322	2,5-25	9	200x100x 36	1,3
72330	4-40	7	305x115x 50	3,8
72348	8-63	5	305x115x 70	7,4
72355	20-100	3	280x215x125	27,1
72165	4-32	5	132x145x 50	1,5
72173	8-50	4	192x158x 75	4,9

### Note:

#### Workshop sets

Size 2.5-25 including (BxHxL):

2.5x8x63 / 3.2x10x63 / 4.0x12x63 / 5.0x16x63 / 6.3x20x63 / 4.0x12x100 / 5.0x16x100 / 6.3x20x100 / 8.0x25x100 mm

Size 4.0-40 including (BxHxL):

4.0x12x100 / 5.0x16x100 / 6.3x20x100 / 8.0x25x100 / 8.0x25x160 / 10.0x32x160 / 12.0x40x160 mm

Size 8.0-63 including (BxHxL):

8.0x25x100 / 10.0x32x100 / 12.0x40x100 / 16.0x50x160 / 20.0x63x160 mm

Size 20-100 including (BxHxL):

20.0x63x250 / 25.0x80x250 / 32.0x100x250 mm

#### Vice sets

Size 4.0-32 including (BxHxL):

4.0x12x100 / 5.0x16x100 / 6.3x20x100 / 8.0x25x100 / 10.0x32x100 mm

Size 8.0-50 including (BxHxL):

8.0x25x160 / 10.0x32x160 / 12.0x40x160 / 16.0x50x160 mm

## DIN 6346P

### Parallel supports-pairs

Plain parallel, fine-ground, in pairs.  
Size data on the product.  
Case-hardened.

Pair tolerance in height tp2 and width tp1 to IT 5.  
Rated dimensional tolerance in height and width to DIN ISO 2768m.  
Remaining dimensions to DIN ISO 2768m.



Order no.	H	B	L	Pair tolerance (tp1 / /tp2)	Weight [g]
75309	8	2,5	63	IT5	20
75317	10	3,2	63	IT5	30
75325	12	4,0	63	IT5	45
75333	16	5,0	63	IT5	80
75341	20	6,3	63	IT5	125
72181	12	4,0	100	IT5	75
72199	16	5,0	100	IT5	125
72207	20	6,3	100	IT5	200
72215	25	8,0	100	IT5	315
72223	32	10,0	100	IT5	500
72231	40	12,0	100	IT5	750
72249	25	8,0	160	IT5	500
72256	32	10,0	160	IT5	800
72264	40	12,0	160	IT5	1200
72272	50	16,0	160	IT5	2000
72280	63	20,0	160	IT5	3170
72298	63	20,0	250	IT5	4950
72306	80	25,0	250	IT5	7900
72314	100	32,0	250	IT5	12680
72363	100	40,0	400	IT5	25300

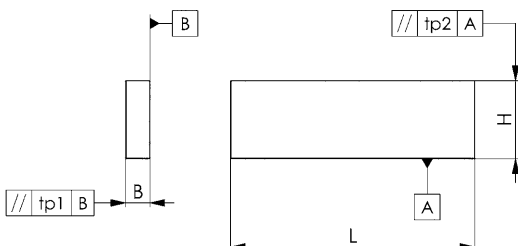

CAD



Subject to technical alterations.

No. 6347

## Parallel support set in wooden box

with 14 pairs of parallel supports.  
Plain parallel, finely ground, in pairs.  
Case-hardened.



Order no.	Quality level	H	H Rated dimensional tolerance	H Pair tolerance (tp)	B	L	Case [mm]	Weight [Kg]
558279	SP	14, 16, 18, 20, 22, 24, 26, 28, 30, 32, 35, 40, 45, 50	$\pm 0,004$	0,004	10	150	435 x 200 x 64	10,9
558280	P	14, 16, 18, 20, 22, 24, 26, 28, 30, 32, 35, 40, 45, 50	$\pm 0,01$	0,01	10	150	435 x 200 x 64	10,9
558281	S	14, 16, 18, 20, 22, 24, 26, 28, 30, 32, 35, 40, 45, 50	2768 - m	0,01	10	150	435 x 200 x 64	10,9

### Design:

Content per 1 pair (WxH):  
10x14 / 10x16 / 10x18 / 10x22 / 10x24 / 10x26 / 10x28 / 10x30 / 10x32 / 10x35 / 10x40 / 10x45 / 10x50 mm.

**Quality level:**  
SP = Super-precision, P = Precision, S = Standard

### Application:

These documents are used as washers for workpieces exposed to diverse machining processes. The high precision of the parallel washers guarantees parallel workpiece clamping.

### Advantage:

- high wear resistance and long service life
- wooden box with removable lid for perfect handling at the workplace and safe storage
- different quality levels for any application

### Note:

Remaining dimensions according to DIN ISO 2768 - m.  
Size data on the product.

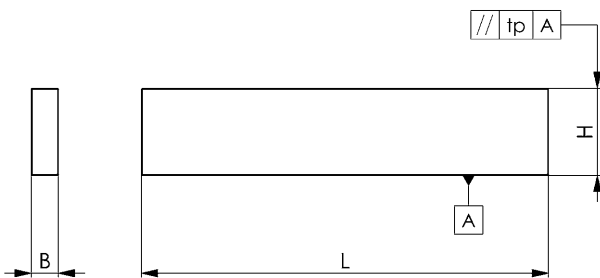

**Optimised wooden case  
for perfect handling!**

## No. 6347PSP

### Parallel supports-pairs, super-precision

Plain parallel, finely ground, in pairs.  
Case-hardened.  
Quality level: Super-precision \*\*\*



Order no.	H Rated dimensional tolerance $\pm 0.004$	H Pair tolerance (tp)	B	L	Weight [g]
75473	14	0,004	10	150	330
75481	16	0,004	10	150	380
75499	18	0,004	10	150	420
75507	20	0,004	10	150	470
75515	22	0,004	10	150	520
75523	24	0,004	10	150	570
75531	26	0,004	10	150	610
75549	28	0,004	10	150	660
75556	30	0,004	10	150	710
75564	32	0,004	10	150	750
75572	35	0,004	10	150	830
75580	40	0,004	10	150	940
75291	45	0,004	10	150	1060
75283	50	0,004	10	150	1180

#### Application:

These documents are used as washers for workpieces exposed to diverse machining processes. The high precision of the parallel washers guarantees parallel workpiece clamping.

#### Note:

Remaining dimensions according to DIN ISO 2768 - m.  
Size data on the product.

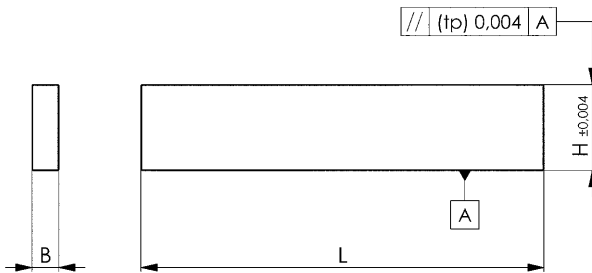

CAD



## No. 6347PP

### Parallel supports-pairs, precision

Plain parallel, finely ground, in pairs.  
Case-hardened.  
Quality level: Precision \*\*



Order no.	H Rated dimensional tolerance $\pm 0.01$	H Pair tolerance (tp)	B	L	Weight [g]
370684	14	0,01	10	150	330
370692	16	0,01	10	150	380
370700	18	0,01	10	150	420
370718	20	0,01	10	150	470
370726	22	0,01	10	150	520
370734	24	0,01	10	150	570
370742	26	0,01	10	150	610
370759	28	0,01	10	150	660
370767	30	0,01	10	150	710
370775	32	0,01	10	150	750
370783	35	0,01	10	150	830
370791	40	0,01	10	150	940
370809	45	0,01	10	150	1060
370817	50	0,01	10	150	1180

#### Application:

These documents are used as washers for workpieces exposed to diverse machining processes.

#### Note:

Remaining dimensions according to DIN ISO 2768 - m.  
Size data on the product.



CAD



Subject to technical alterations.

## No. 6347PS

### Parallel supports-pairs, standard

Plain parallel, finely ground, in pairs.  
Case-hardened.  
Quality level: Standard \*



Order no.	H Rated dimensional tolerance DIN ISO 2768 - m	H Pair tolerance (tp)	B	L	Weight [g]
370825	14	0,01	10	150	330
370833	16	0,01	10	150	380
370841	18	0,01	10	150	420
370858	20	0,01	10	150	470
370866	22	0,01	10	150	520
370874	24	0,01	10	150	570
370882	26	0,01	10	150	610
370890	28	0,01	10	150	660
370908	30	0,01	10	150	710
370916	32	0,01	10	150	750
370924	35	0,01	10	150	830
370932	40	0,01	10	150	940
370940	45	0,01	10	150	1060
370957	50	0,01	10	150	1180

### Application:

These documents are used as washers for workpieces exposed to diverse machining processes.

### Note:

Remaining dimensions according to DIN ISO 2768 - m.  
Size data on the product.

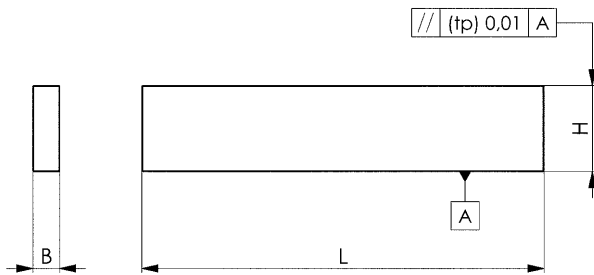

Subject to technical alterations.

CAD



## No. 6348

### Parallel support set in wooden stand

Plain parallel, finely ground, in pairs.  
Case-hardened.



Order no.	Quality level	Size	Pair	H Rated dimensional tolerance	H Pair tolerance (tp)	B Rated dimensional tolerance	L	Box LK x WK x HK [mm]	Weight [Kg]
75606	SP	100	20	±0,01	IT5	±0,01	100	142x123x56	2,2
75614	SP	125	24	±0,01	IT5	±0,01	125	276x162x55	14
75648	SP	150	24	±0,01	IT5	±0,01	150	276x162x55	17
371062	P	100	20	±0,01	IT5	2768 - m	100	142x123x56	2,2
371070	P	125	24	±0,01	IT5	2768 - m	125	276x162x55	14
371088	P	150	24	±0,01	IT5	2768 - m	150	276x162x55	17
371096	S	100	20	2768 - m	IT5	2768 - m	100	142x123x56	2,2
371104	S	125	24	2768 - m	IT5	2768 - m	125	276x162x55	14
371112	S	150	24	2768 - m	IT5	2768 - m	150	276x162x55	17

### Design:

Size 100, content per 1 pair (WxH):

2x5 / 2x10 / 2x15 / 2x20 / 3x6 / 3x11 / 3x16 / 3x21 / 4x7 / 4x12 / 4x17 / 4x22 / 5x8 / 5x13 / 5x18 / 5x23 / 6x9 / 6x14 / 6x19 / 6x24 mm

Size 125 and 150, content per 1 pair (WxH):

8x11 / 8x16 / 8x21 / 8x26 / 8x31 / 8x36 / 10x13 / 10x18 / 10x23 / 10x28 / 10x33 / 10x38 / 12x15 / 12x20 / 12x25 / 12x30 / 12x35 / 12x40 / 14x17 / 14x22 / 14x27 / 14x32 / 14x37 / 14x42 mm

### Quality level:

SP = Super-precision, P = Precision, S = Standard

### Application:

These documents are used as washers for workpieces exposed to diverse machining processes. The high precision of the parallel washers guarantees parallel workpiece clamping.

### Advantage:

- high wear resistance and long service life
- wooden box for perfect handling at the workplace and safe storage
- different quality levels for any application

### Note:

Remaining dimensions according to DIN ISO 2768 - m.  
Size data on front of product.

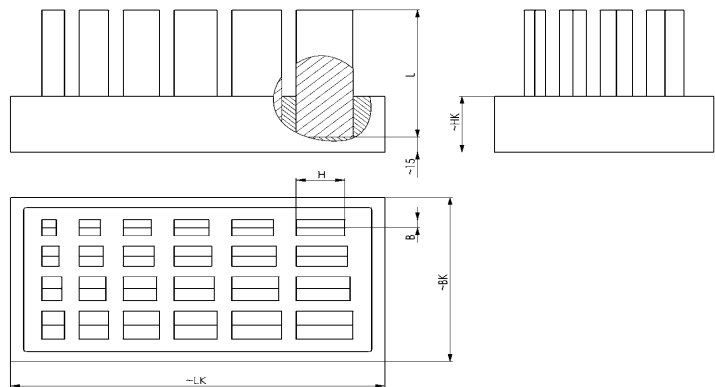
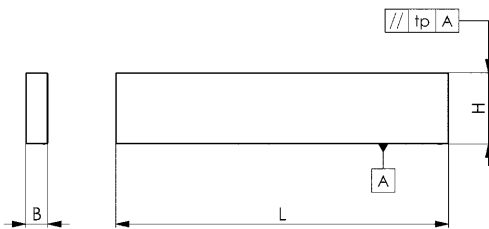

## No. 6348PSP

### Parallel supports-pairs, super-precision, 100 mm long

Plain parallel, finely ground, in pairs.  
Case-hardened.  
Quality level: Super-precision \*\*\*



Order no.	H Rated dimensional tolerance ±0.01	H Pair tolerance (tp)	B Rated dimensional tolerance ±0.01	L	Weight [g]
370007	5	IT5	2	100	16
370015	10	IT5	2	100	31
370023	15	IT5	2	100	47
370031	20	IT5	2	100	62
370049	6	IT5	3	100	28
370056	11	IT5	3	100	51
370064	16	IT5	3	100	75
370072	21	IT5	3	100	98
370080	7	IT5	4	100	44
370098	12	IT5	4	100	75
370106	17	IT5	4	100	106
370114	22	IT5	4	100	137
370122	8	IT5	5	100	62
370130	13	IT5	5	100	101
370148	18	IT5	5	100	140
370155	23	IT5	5	100	179
370163	9	IT5	6	100	84
370171	14	IT5	6	100	131
370189	19	IT5	6	100	178
370197	24	IT5	6	100	224

#### Application:

These documents are used as washers for workpieces exposed to diverse machining processes. The high precision of the parallel washers guarantees parallel workpiece clamping.

#### Note:

Remaining dimensions according to DIN ISO 2768 - m.  
Size data on the product.

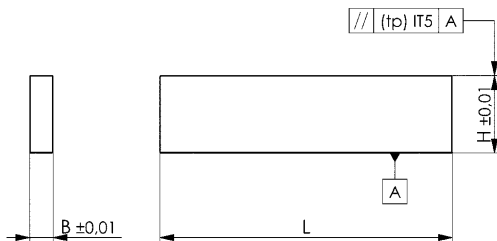

## No. 6348PSP

### Parallel supports-pairs, super-precision, 125 mm long

Plain parallel, finely ground, in pairs.  
Case-hardened.  
Quality level: Super-precision \*\*\*



Order no.	H Rated dimensional tolerance ±0.01	H Pair tolerance (tp)	B Rated dimensional tolerance ±0.01	L	Weight [g]
370205	11	IT5	8	125	171
370213	16	IT5	8	125	249
370221	21	IT5	8	125	326
370239	26	IT5	8	125	404
370247	31	IT5	8	125	482
370254	36	IT5	8	125	561
370262	13	IT5	10	125	253
370270	18	IT5	10	125	351
370288	23	IT5	10	125	448
370296	28	IT5	10	125	545
370304	33	IT5	10	125	642
370312	38	IT5	10	125	741
370320	15	IT5	12	125	350
370338	20	IT5	12	125	466
370346	25	IT5	12	125	583
370353	30	IT5	12	125	700
370361	35	IT5	12	125	817
370379	40	IT5	12	125	933
370387	17	IT5	14	125	462
370395	22	IT5	14	125	599
370403	27	IT5	14	125	734
370411	32	IT5	14	125	871
370429	37	IT5	14	125	1009
370437	42	IT5	14	125	1144

#### Application:

These documents are used as washers for workpieces exposed to diverse machining processes. The high precision of the parallel washers guarantees parallel workpiece clamping.

#### Note:

Remaining dimensions according to DIN ISO 2768 - m.  
Size data on the product.

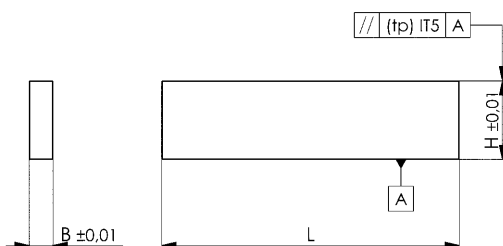

Subject to technical alterations.

## No. 6348PSP

### Parallel supports-pairs, super-precision, 150 mm long

Plain parallel, finely ground, in pairs.  
Case-hardened.  
Quality level: Super-precision \*\*\*

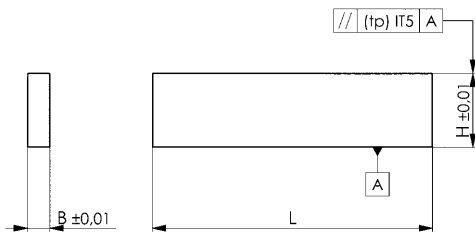

Order no.	H Rated dimensional tolerance ±0.01	H Pair tolerance (tp)	B Rated dimensional tolerance ±0.01	L	Weight [g]
370445	11	IT5	8	150	203
370452	16	IT5	8	150	295
370460	21	IT5	8	150	389
370478	26	IT5	8	150	482
370486	31	IT5	8	150	574
370494	36	IT5	8	150	668
370502	13	IT5	10	150	300
370510	18	IT5	10	150	417
370528	23	IT5	10	150	533
370536	28	IT5	10	150	649
370544	33	IT5	10	150	768
370551	38	IT5	10	150	884
370569	15	IT5	12	150	416
370577	20	IT5	12	150	556
370585	25	IT5	12	150	694
370593	30	IT5	12	150	835
370601	35	IT5	12	150	974
370619	40	IT5	12	150	1113
370627	17	IT5	14	150	550
370635	22	IT5	14	150	714
370643	27	IT5	14	150	879
370650	32	IT5	14	150	1040
370668	37	IT5	14	150	1203
370676	42	IT5	14	150	1369

#### Application:

These documents are used as washers for workpieces exposed to diverse machining processes. The high precision of the parallel washers guarantees parallel workpiece clamping.

#### Note:

Remaining dimensions according to DIN ISO 2768 - m.  
Size data on the product.

CAD



## No. 6348PP

### Parallel supports-pairs, precision, 100 mm long

Plain parallel, finely ground, in pairs.  
Case-hardened.  
Quality level: Precision \*\*

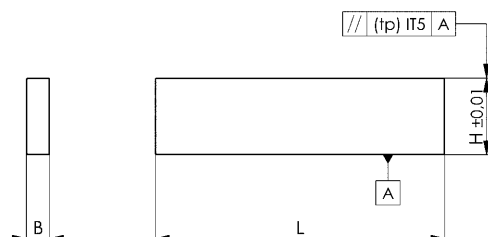

Order no.	H Rated dimensional tolerance ±0.01	H Pair tolerance (tp)	B	L	Weight [g]
371120	5	IT5	2	100	16
371138	10	IT5	2	100	31
371146	15	IT5	2	100	47
371153	20	IT5	2	100	62
371161	6	IT5	3	100	28
371179	11	IT5	3	100	51
371187	16	IT5	3	100	75
371195	21	IT5	3	100	98
371203	7	IT5	4	100	44
371211	12	IT5	4	100	75
371229	17	IT5	4	100	106
371237	22	IT5	4	100	137
371245	8	IT5	5	100	62
371252	13	IT5	5	100	101
371260	18	IT5	5	100	140
371278	23	IT5	5	100	179
371286	9	IT5	6	100	84
371294	14	IT5	6	100	131
371302	19	IT5	6	100	178
371310	24	IT5	6	100	224

#### Application:

These documents are used as washers for workpieces exposed to diverse machining processes.

#### Note:

Remaining dimensions according to DIN ISO 2768 - m.  
Size data on front of product.

CAD



Subject to technical alterations.

## No. 6348PP

### Parallel supports-pairs, precision, 125 mm long

Plain parallel, finely ground, in pairs.  
Case-hardened.  
Quality level: Precision \*\*

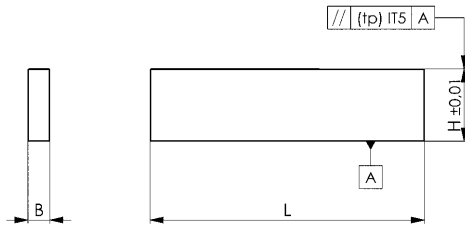

Order no.	H Rated dimensional tolerance ±0.01	H Pair tolerance (tp)	B	L	Weight [g]
371328	11	IT5	8	125	171
371336	16	IT5	8	125	249
371344	21	IT5	8	125	326
371351	26	IT5	8	125	404
371369	31	IT5	8	125	482
371377	36	IT5	8	125	561
371385	13	IT5	10	125	253
371393	18	IT5	10	125	351
371401	23	IT5	10	125	448
371419	28	IT5	10	125	545
371427	33	IT5	10	125	642
371435	38	IT5	10	125	741
371443	15	IT5	12	125	350
371450	20	IT5	12	125	466
371468	25	IT5	12	125	583
371476	30	IT5	12	125	700
371484	35	IT5	12	125	817
371492	40	IT5	12	125	933
371500	17	IT5	14	125	462
371518	22	IT5	14	125	599
371526	27	IT5	14	125	734
371534	32	IT5	14	125	871
371542	37	IT5	14	125	1009
371559	42	IT5	14	125	1144

#### Application:

These documents are used as washers for workpieces exposed to diverse machining processes.

#### Note:

Remaining dimensions according to DIN ISO 2768 - m.  
Size data on front of product.

CAD



## No. 6348PP

### Parallel supports-pairs, precision, 150 mm long

Plain parallel, finely ground, in pairs.  
Case-hardened.  
Quality level: Precision \*\*

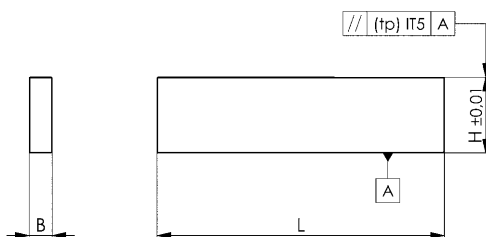

Order no.	H Rated dimensional tolerance ±0.01	H Pair tolerance (tp)	B	L	Weight [g]
372243	11	IT5	8	150	203
372250	16	IT5	8	150	295
372268	21	IT5	8	150	389
372276	26	IT5	8	150	482
372284	31	IT5	8	150	574
372292	36	IT5	8	150	668
372300	13	IT5	10	150	300
372318	18	IT5	10	150	417
372326	23	IT5	10	150	533
372334	28	IT5	10	150	649
372342	33	IT5	10	150	768
372359	38	IT5	10	150	884
372367	15	IT5	12	150	416
372375	20	IT5	12	150	556
372383	25	IT5	12	150	694
372391	30	IT5	12	150	835
372409	35	IT5	12	150	974
372417	40	IT5	12	150	1113
372425	17	IT5	14	150	550
372433	22	IT5	14	150	714
372441	27	IT5	14	150	879
372458	32	IT5	14	150	1040
372466	37	IT5	14	150	1203
372474	42	IT5	14	150	1369

#### Application:

These documents are used as washers for workpieces exposed to diverse machining processes.

#### Note:

Remaining dimensions according to DIN ISO 2768 - m.  
Size data on front of product.

CAD



Subject to technical alterations.

## No. 6348PS

### Parallel supports-pairs, standard, 100 mm long

Plain parallel, finely ground, in pairs.  
Case-hardened.  
Quality level: Standard \*

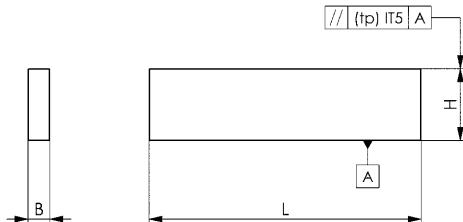

Order no.	H Rated dimensional tolerance DIN ISO 2768 - m	H Pair tolerance (tp)	B	L	Weight [g]
371807	5	IT5	2	100	16
371815	10	IT5	2	100	31
371823	15	IT5	2	100	47
371831	20	IT5	2	100	62
371849	6	IT5	3	100	28
371856	11	IT5	3	100	51
371864	16	IT5	3	100	75
371872	21	IT5	3	100	98
371880	7	IT5	4	100	44
371898	12	IT5	4	100	75
371906	17	IT5	4	100	106
371914	22	IT5	4	100	137
371922	8	IT5	5	100	62
371930	13	IT5	5	100	101
371948	18	IT5	5	100	140
371955	23	IT5	5	100	179
371963	9	IT5	6	100	84
371971	14	IT5	6	100	131
371989	19	IT5	6	100	178
371997	24	IT5	6	100	224

### Application:

These documents are used as washers for workpieces exposed to diverse machining processes.

### Note:

Remaining dimensions according to DIN ISO 2768 - m.  
Size data on front of product.

CAD



## No. 6348PS

### Parallel supports-pairs, standard, 125 mm long

Plain parallel, finely ground, in pairs.  
Case-hardened.  
Quality level: Standard \*

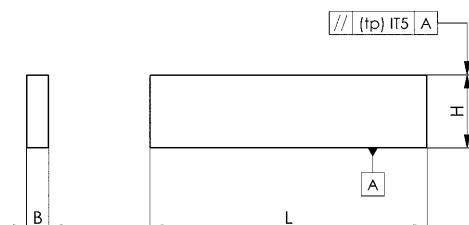

Order no.	H Rated dimensional tolerance DIN ISO 2768 - m	H Pair tolerance (tp)	B	L	Weight [g]
372003	11	IT5	8	125	171
372011	16	IT5	8	125	249
372029	21	IT5	8	125	326
372037	26	IT5	8	125	404
372045	31	IT5	8	125	482
372052	36	IT5	8	125	561
372060	13	IT5	10	125	253
372078	18	IT5	10	125	351
372086	23	IT5	10	125	448
372094	28	IT5	10	125	545
372102	33	IT5	10	125	642
372110	38	IT5	10	125	741
372128	15	IT5	12	125	350
372136	20	IT5	12	125	466
372144	25	IT5	12	125	583
372151	30	IT5	12	125	700
372169	35	IT5	12	125	817
372177	40	IT5	12	125	933
372185	17	IT5	14	125	462
372193	22	IT5	14	125	599
372201	27	IT5	14	125	734
372219	32	IT5	14	125	871
372227	37	IT5	14	125	1009
372235	42	IT5	14	125	1144

### Application:

These documents are used as washers for workpieces exposed to diverse machining processes.

### Note:

Remaining dimensions according to DIN ISO 2768 - m.  
Size data on front of product.

CAD



Subject to technical alterations.

## No. 6348PS

### Parallel supports-pairs, standard, 150 mm long

Plain parallel, finely ground, in pairs.  
Case-hardened.  
Quality level: Standard \*



Order no.	H Rated dimensional tolerance DIN ISO 2768 - m	H Pair tolerance (tp)	B	L	Weight [g]
371567	11	IT5	8	150	203
371575	16	IT5	8	150	295
371583	21	IT5	8	150	389
371591	26	IT5	8	150	482
371609	31	IT5	8	150	574
371617	36	IT5	8	150	668
371625	13	IT5	10	150	300
371633	18	IT5	10	150	417
371641	23	IT5	10	150	533
371658	28	IT5	10	150	649
371666	33	IT5	10	150	768
371674	38	IT5	10	150	884
371682	15	IT5	12	150	416
371690	20	IT5	12	150	556
371708	25	IT5	12	150	694
371716	30	IT5	12	150	835
371724	35	IT5	12	150	974
371732	40	IT5	12	150	1113
371740	17	IT5	14	150	550
371757	22	IT5	14	150	714
371765	27	IT5	14	150	879
371773	32	IT5	14	150	1040
371781	37	IT5	14	150	1203
371799	42	IT5	14	150	1369

#### Application:

These documents are used as washers for workpieces exposed to diverse machining processes.

#### Note:

Remaining dimensions according to DIN ISO 2768 - m.  
Size data on front of product.

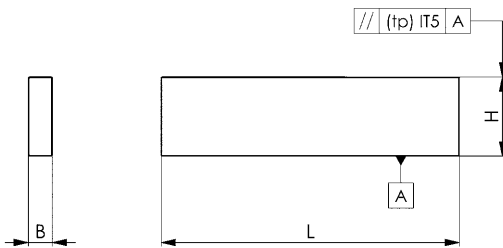

CAD

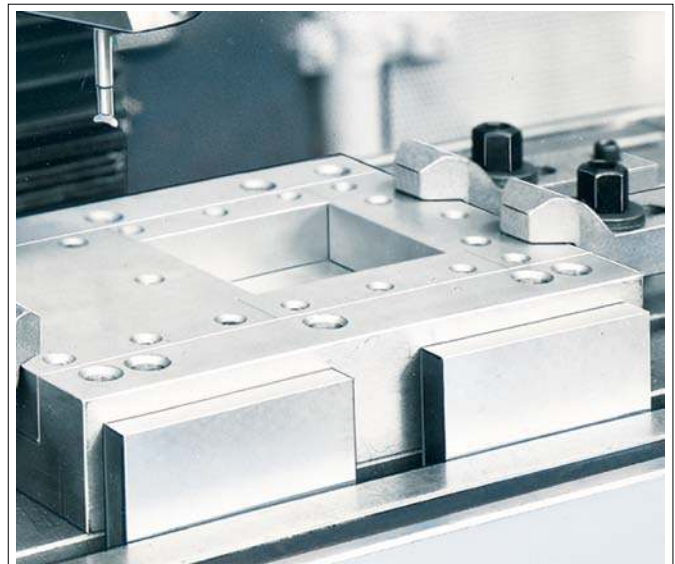
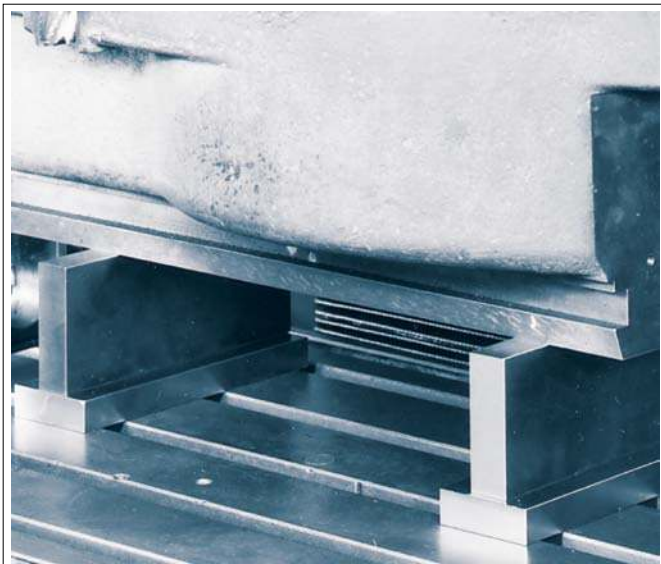

Subject to technical alterations.

## No. 6349PP

### Parallel supports-pairs, precision

Plain parallel, finely ground, in pairs.  
Case-hardened.  
Quality level: Precision \*\*

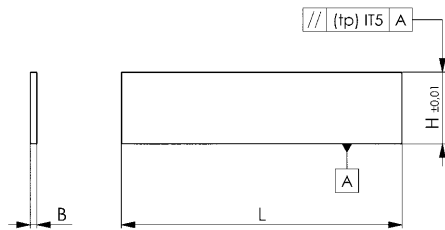

Order no.	H Rated dimensional tolerance ±0.01	H Pair tolerance (tp)	B	L	Weight [g]
372508	11	IT5	3	125	64
372516	12	IT5	3	125	70
372524	13	IT5	3	125	76
372532	14	IT5	3	125	82
372540	15	IT5	3	125	88
372557	16	IT5	3	125	94
372565	17	IT5	3	125	100
372573	18	IT5	3	125	106
372581	19	IT5	3	125	112
372599	20	IT5	3	125	118
372607	21	IT5	3	125	124
372615	22	IT5	3	125	130
372623	23	IT5	3	125	136
372631	24	IT5	3	125	142
372649	25	IT5	3	125	148
372656	26	IT5	3	125	154
372664	27	IT5	3	125	160
372672	28	IT5	3	125	164
372680	29	IT5	3	125	170
372698	30	IT5	3	125	176
372706	31	IT5	3	125	182
372714	32	IT5	3	125	188
372722	33	IT5	3	125	194
372730	34	IT5	3	125	200
372748	35	IT5	3	125	206
372755	36	IT5	3	125	212
372763	37	IT5	3	125	218
372771	38	IT5	3	125	224
372789	39	IT5	3	125	230
372797	40	IT5	3	125	236
372805	41	IT5	3	125	242
372813	42	IT5	3	125	248

### Application:

These documents are used as washers for workpieces exposed to diverse machining processes.

### Note:

Remaining dimensions according to DIN ISO 2768 - m.  
Size data on front of product.

CAD



Subject to technical alterations.

## No. 6349P

### Parallel supports-pairs, precision

In wooden stand.  
Plain parallel, finely ground, in pairs.  
Case-hardened.  
Quality level: Precision \*\*



Order no.	Size	Pair	H Rated dimensional tolerance $\pm 0.01$	H Pair tolerance (tp)	B	L	Weight [Kg]
372482	24	24	11, 13, 15, 16, 17, 18, 20, 21, 22, 23, 25, 26, 27, 28, 30, 31, 32, 33, 35, 36, 37, 38, 40, 42	IT5	3	125	4,5
372490	32	32	11, 12, 13, 14, 15, 16, 17, 18, 19, 20, 21, 22, 23, 24, 25, 26, 27, 28, 29, 30, 31, 32, 33, 34, 35, 36, 37, 38, 39, 40, 42	IT5	3	125	5,5

#### Design:

Size 24, content per 1 pair (W x H):

3x11 / 3x13 / 3x15 / 3x16 / 3x17 / 3x18 / 3x20 / 3x21 / 3x22 / 3x23 / 3x25 / 3x26 / 3x27 / 3x28 / 3x30 / 3x31 / 3x32 / 3x33 / 3x35 / 3x36 / 3x37 / 3x38 / 3x40 / 3x42 mm.

Size 32 content per 1 pair (W x H):

3x11 / 3x12 / 3x13 / 3x14 / 3x15 / 3x16 / 3x17 / 3x18 / 3x19 / 3x20 / 3x21 / 3x22 / 3x23 / 3x24 / 3x25 / 3x26 / 3x27 / 3x28 / 3x29 / 3x30 / 3x31 / 3x32 / 3x33 / 3x34 / 3x35 / 3x36 / 3x37 / 3x38 / 3x39 / 3x40 / 3x41 / 3x42 mm.

Wooden stand: 276 x 162 x 55 mm

#### Application:

These documents are used as washers for workpieces exposed to diverse machining processes.

#### Advantage:

- high wear resistance and long service life
- Wooden stand for perfect handling at the workplace.

#### Note:

Remaining dimensions according to DIN ISO 2768 - m.  
Size data on front of product.

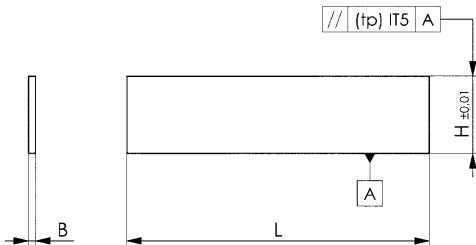

## No. 6344SP

### Parallel supports-set, corrugated

In wooden box with folding lid.  
Hardened, tempered spring steel.  
Precision ground.  
Height graduation 2 mm.  
Quality level: Super-precision \*\*\*

Pair tolerance tp in height IT 5.  
Rated dimensional tolerance in height  $\pm 0.004$  mm.  
Remaining dimensions according to DIN ISO 2768 - m.

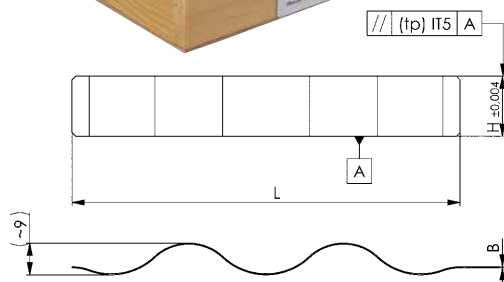

Order no.	Size	Pair	H $\pm 0.004$	H Pair tolerance (tp)	B	L	Weight [g]
372821	9 -23	8	9, 11, 13, 15, 17, 19, 21, 23	IT5	0,3	110	450
372839	25-39	8	25, 27, 29, 31, 33, 35, 37, 39	IT5	0,3	110	490

#### Design:

Size 9-23, 1 pair each (B x H):

0.3x9 / 0.3x11 / 0.3x13 / 0.3x15 / 0.3x17 / 0.3x19 / 0.3x21 / 0.3x23 mm.

Size 25-39, 1 pair each (B x H):

0.3x25 / 0.3x27 / 0.3x29 / 0.3x31 / 0.3x33 / 0.3x35 / 0.3x37 / 0.3x39 mm.

#### Application:

The corrugated parallel washers create a time-saving when clamping workpieces for grinding, milling, cutting, boring, etc.

#### Advantage:

- no swarf remains on the mounting surface
- parallelism of the clamped workpiece is not affected
- several flat or single thin workpieces can easily be clamped.

Subject to technical alterations.

## No. 6350

### Parallel stops in pairs

For machine grooves.  
Can also be used as parallel washers.  
Plain parallel in height, fine-ground, in pairs.  
Case-hardened.



Order no.	B	H	H Pair tolerance (tp)	L	Weight [g]
74260	8	25	IT5	100	315
74278	10	32	IT5	100	500
74286	12	40	IT5	100	750
74294	14	50	IT5	100	1100
74302	16	50	IT5	160	2000
74310	18	63	IT5	160	2850
74328	20	63	IT5	160	3170
74336	22	80	IT5	160	4400
74344	24	80	IT5	160	4800
74351	28	100	IT5	160	7000

### Application:

The parallel stops are intended primarily for small to medium-sized machines. Their thickness is matched to the machine groove with a tolerance of H8. A pair of these stops is inserted into a machine groove, allowing the workpieces to be quickly positioned parallel to the table.

### Note:

Rated dimensional tolerance in height according to DIN ISO 2768 - m.  
Rated dimensional tolerance in width according to DIN EN ISO 286: h7.  
Remaining dimensions according to DIN ISO 2768 -m.

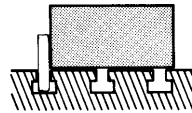
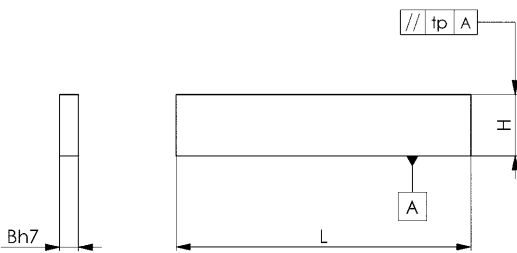

## No. 6328

### Cylindrical stop

case hardened and ground. The short version, ground to  $\pm 0.01$  mm tolerance in height can be used as support.



Order no.	Slot	A h6	B -0.6	D $\pm 0.01$	H1 $\pm 0.01$ short	H1 $\pm 0.2$ long	H2	H3	Screw ISO 4762	Weight [g]
75150	12	0-0,011	12	20	15	-	8	6	M6x25	55
75192	12	0-0,011	12	20	-	25	8	6	M6x35	80
75200	14	0-0,011	14	32	25	-	9	8	M8x35	200
75218	14	0-0,011	14	32	-	50	9	8	M8x60	355
75168	16	0-0,011	16	32	25	-	10	8	M8x45	220
75176	16	0-0,011	16	32	-	50	10	8	M8x70	375
75226	18	0-0,011	18	40	25	-	15	10	M10x50	360
75234	18	0-0,011	18	40	-	50	15	10	M10x75	600
75242	22	0-0,013	20	40	25	-	15	14	M10x55	410
75259	22	0-0,013	20	40	-	50	15	14	M10x80	650
75267	28	0-0,013	22	46	25	-	20	16	M12x60	630
75275	28	0-0,013	22	46	-	50	20	16	M12x90	950

### On request:

Further sizes available.

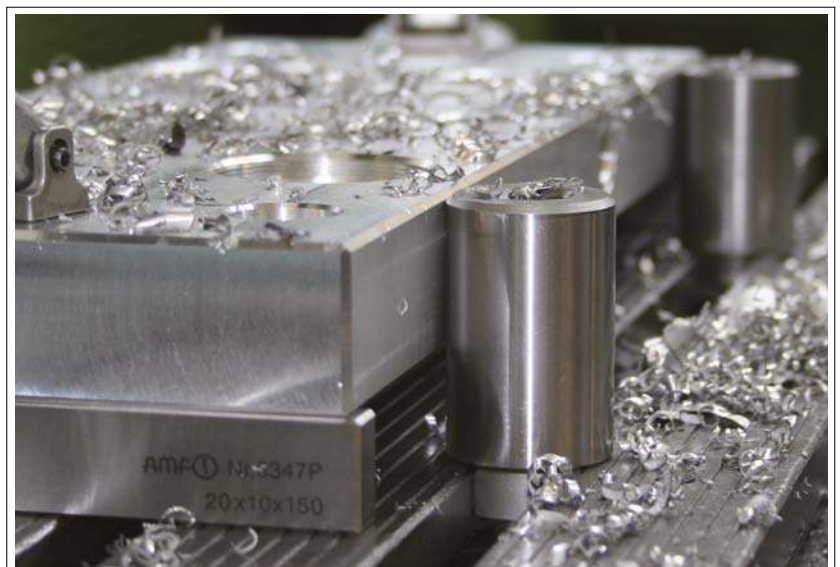
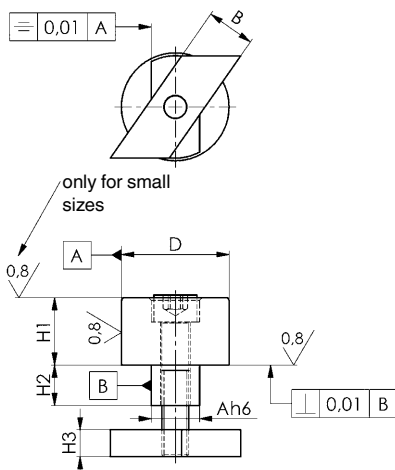

Subject to technical alterations.

## No. 6351

### Parallel stop

case hardened and ground. Parallelism within 0.02 mm. Nominal tolerance DIN 7168 medium.



Order no.	Slot	B	C	H	L	suitable bolt combination: DIN508, ISO4762, DIN6340, DIN787 compl.	Weight [Kg]
74369	10-24	60	40	30	125	M10x10-M20x24	1,6
74377	12-36	80	55	60	160	M12x12-M24x36	5,7
74385	12-36	100	75	100	160	M12x12-M24x36	12,1

### Application:

Parallel stops are the ideal setting elements for medium and large sized machines. Fixed type blocks. 6322 A and sliding blocks DIN 6323 fit the 20H7 slots of the parallel stop. Combinations with the various precision blocks allow use on tables with different slot sizes.

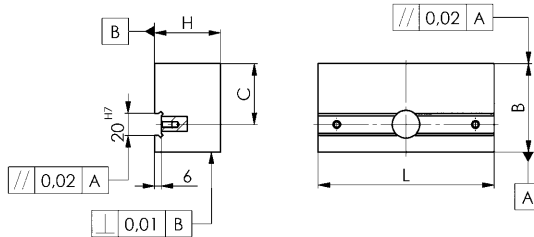

CAD



## No. 6353

### Precision angle stop

case hardened and ground.  
Setting: parallel and at angles of 30, 45, 60 and 90° related to T-slots. Guaranteed precision for all faces according to slots ±30°.



Order no.	Size	Slot	B	D	E	F	H	L	Weight [g]
74450	125	10-20	68	17	66,5	34	15	125	550
74468	200	12-36	98	25	100,0	49	20	200	1900

### Application:

Fixed type tenons no. 6322A and loose type tenons DIN 6323 match with the mentioned table slots. The universal stops can alternatively be fastened complete with T-slots bolts DIN 787 or with T-nuts DIN 508 with screws ISO 4762 and washers DIN 6340. The high precision of the above mentioned universal stops guarantees the positioning accuracy required for almost any machining job. Machining can start straight away. There is no need to meter stop.

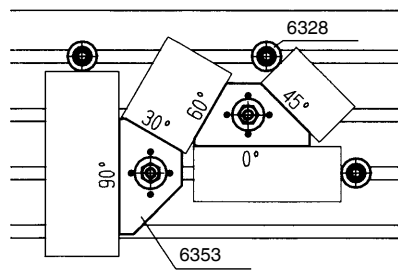
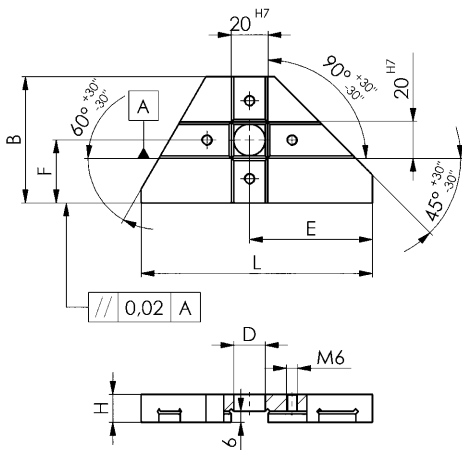

CAD



Subject to technical alterations.

## No. 6355V

### Prismatic clamping block

case hardened and ground

Order no.	Size	B	D	E ±0.01	F	G1	G2	H1 ±0.014	H2	L1	L2	L3	Weight [Kg]
75085	12-65	80	12-65	30,0	15	M 12	M 8	35	60	100	56	27	3,2
75093	20-110	125	20-110	52,5	25	M 16	M 10	55	100	100	53	32	8,1

### Application:

For alignment and clamping of round shafts and workpieces parallel and centric to a table slot. Can be used as parallel stops and supports!

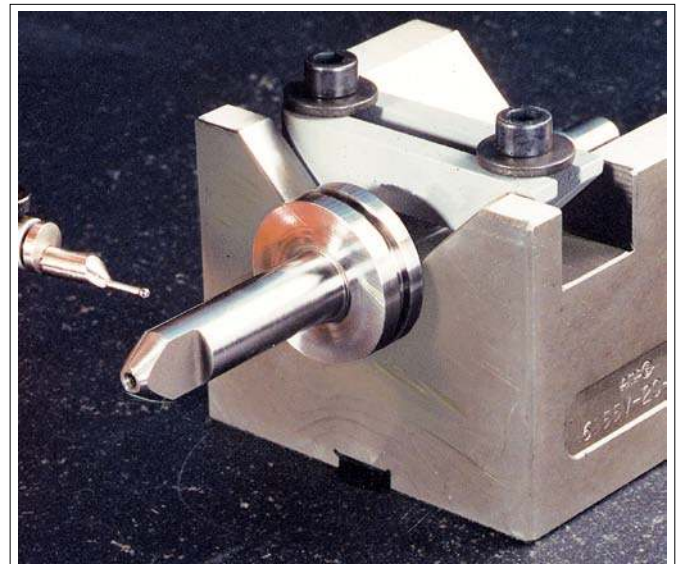
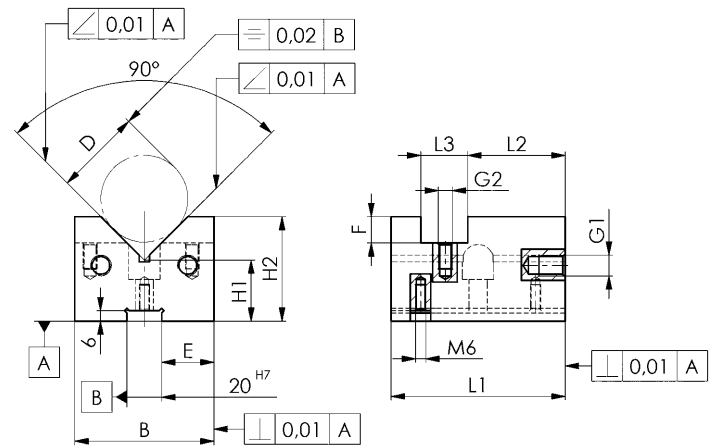

Subject to technical alterations.



## No. 6357

### Stop, adjustable

with hexagon key.  
Tempering steel



Order no.	Size	Slot	B1	B2	C	H	H1	L1	L2	L3	Weight [g]
75655	2	10, 12, 14, 16, 18	11	60	0-110	30-190	200	120	52	30	2450
75663	3	16, 18, 20, 22, 24, 28	17	80	0-110	30-190	200	160	73	40	3250

### Application:

The quickly adjustable stop is suitable for positioning workpieces on various tooling machines and vices. It has a wide range for height and length adjustments. Setting is done with the supplied T-handle hexagon key.

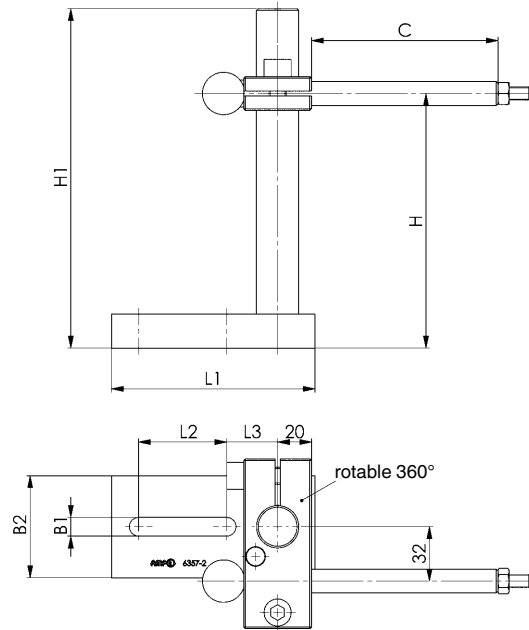

## No. 6358

### Side stop

Tempering steel blued, with 2 threaded holes M16 for 2 positions. Set screw DIN 915 M16x80.



Order no.	Slot	B	C	H1	H2	L	Weight [g]
75879	18	20	20	100	40	50	805
75895	22	25	30	125	40	80	1920
75903	24	32	40	150	65	100	3515
75911	28	32	40	150	65	100	3645

### Application:

The stop is used for safe positioning of long and heavy workpieces on slotted machine tables. It is inserted into the slot - at an inclined position due to its undersize and locks the workpiece against the parallel stop, e.g. no. 6351.

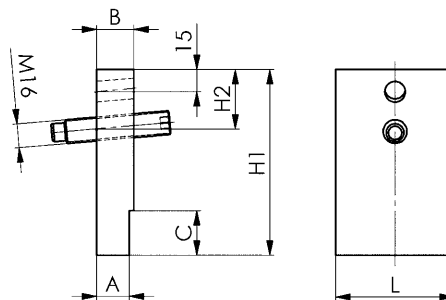

Subject to technical alterations.

## DIN 6323

### Loose type tenons

Steel C15, case hardened and ground.

Order no.	Nominal width of T-slot on fixture B1	Nominal width of T-slot on machine B2	Form	H1	H2	H3	H4	L	Weight [g]
71811	12	10	A	12,0	3,6	-	-	20	20
71829	12	12	B	28,6	-	5,5	9	20	45
71837	20	12	A	14,0	5,5	-	-	32	50
71845	20	14	A	14,0	5,5	-	-	32	55
71852	20	16	A	14,0	5,5	-	-	32	60
71860	20	18	A	14,0	5,5	-	-	32	65
71878	20	20	B	45,5	-	7	16	32	200
71886	20	22	C	50,5	-	7	18	40	290
71894	20	24	C	55,5	-	7	20	40	350
71902	20	28	C	61,5	-	7	24	40	460
71910	20	36	C	76,5	-	7	30	50	940

### Application:

After rough alignment of fixture, the tenons DIN 6323 are pushed into T-slot from the side. No fixed T-nuts can obstruct the transport of fixtures and no damage to machine tables can occur.

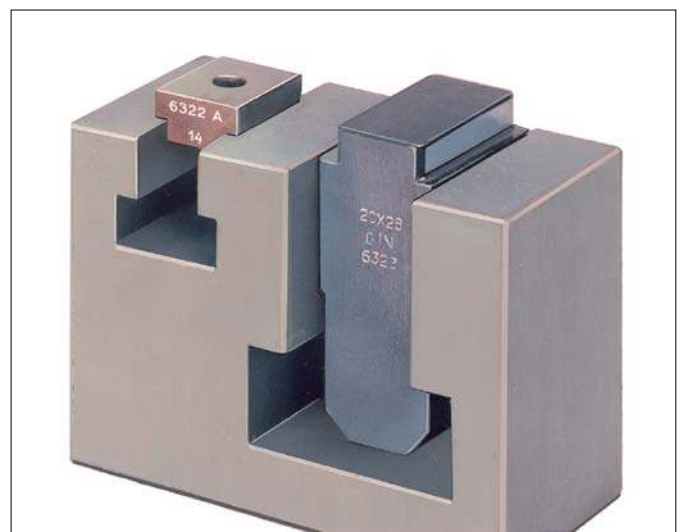
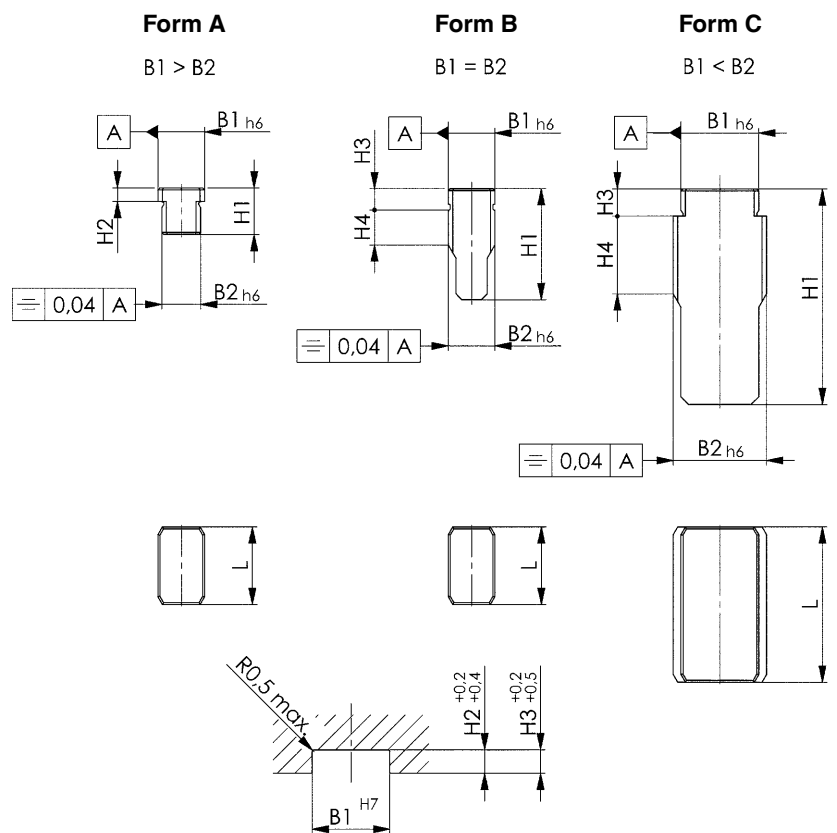

Subject to technical alterations.



## No. 6322A

### Fixed type tenons

Steel C15, case hardened and ground.



Order no.	Nominal width of T-slot on machine B	Nominal width of T-slot on fixture	Form	H	L	Screw DIN84 or ISO4762	Weight [g]
71555	10	20	A	10	22	M6x10	20
71563	12	20	A	10	22	M6x10	25
71571	14	20	A	10	25	M6x16	28
71589	16	20	A	10	25	M6x16	30
71597	18	20	A	10	25	M6x16	30
71613	22	20	C	12	32	M6x16	50
71621	24	20	C	12	32	M6x16	55
71639	28	20	C	12	32	M6x16	60
71647	36	20	C	12	32	M6x16	75

### Application:

These fixed type tenons are screwed in pairs into the standard 20 mm wide set slots of vices or fixtures. By changing the tenons you can work on machines with different slot sizes. For very heavy fixtures we recommend the use of loose type tenons DIN 6323.

"A"

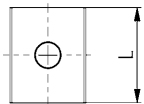
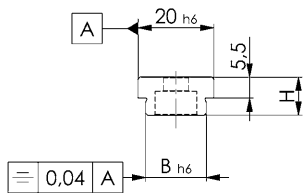

"C"

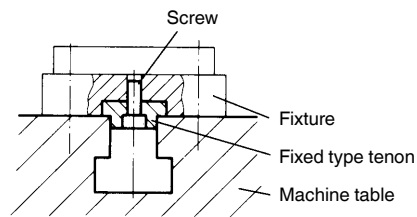
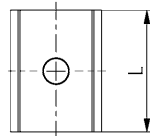
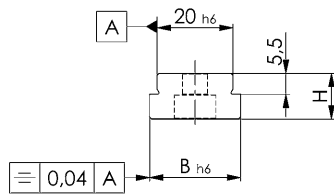

## No. 6322B

### Low type tenons

Steel C15, case hardened and ground.



Order no.	B	H	L	Screw DIN84 or ISO4762	Weight [g]
71696	10	8	20	M4x10	11
71704	12	8	20	M5x12	12
71712	14	10	22	M6x16	18
71720	16	10	22	M6x16	22
71738	18	10	22	M6x16	25
71746	20	10	22	M6x16	30
71753	22	12	32	M6x16	60
71761	24	12	32	M6x16	65

### Application:

Low-type tenons are useful and inexpensive to use, when a fixture is always used on the same machine. For very heavy fixtures we recommend the use of loose type tenons DIN 6323.

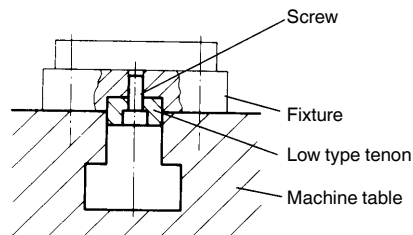
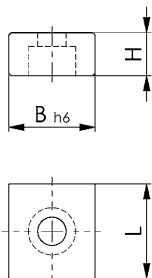

Subject to technical alterations.

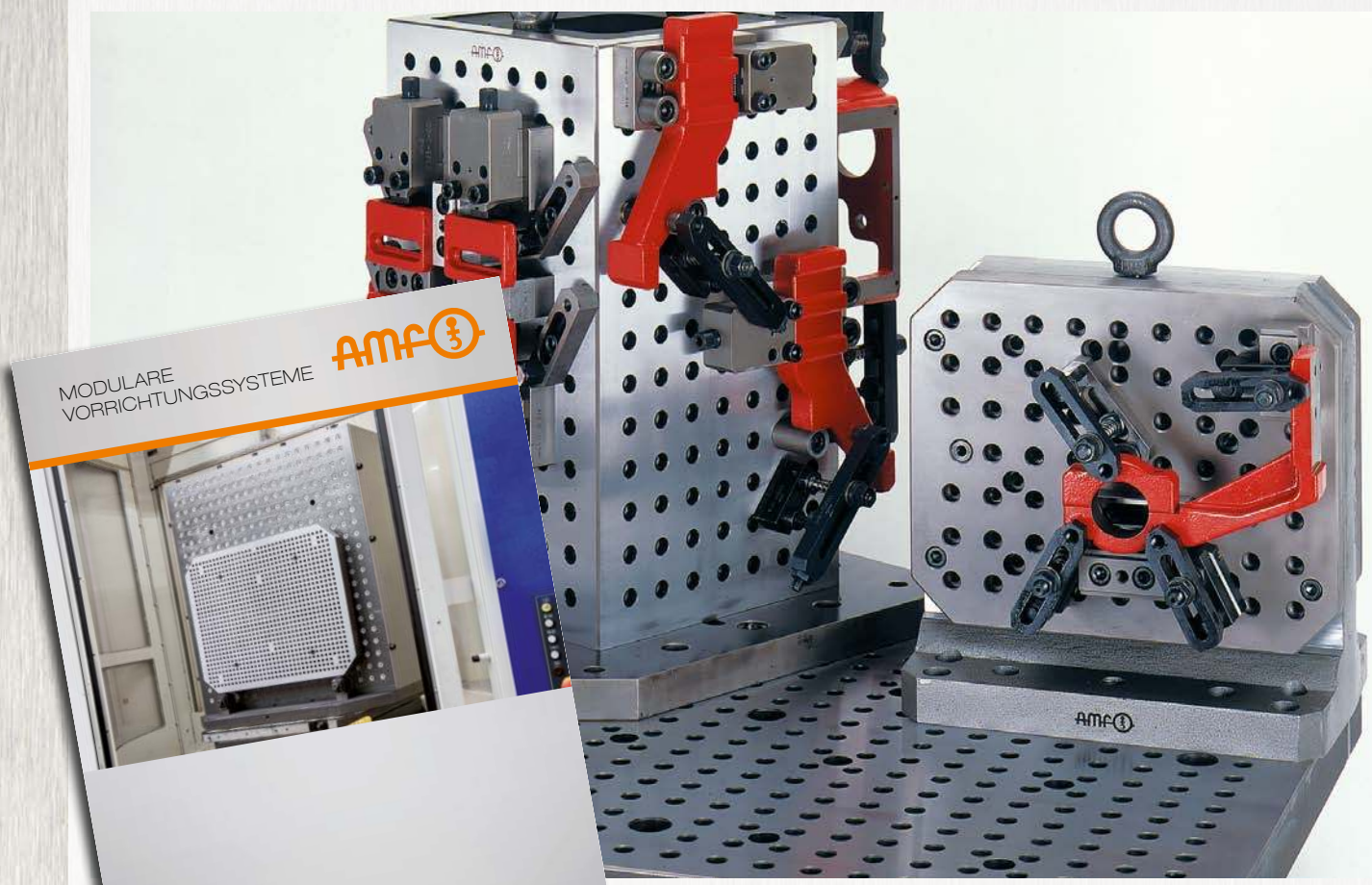
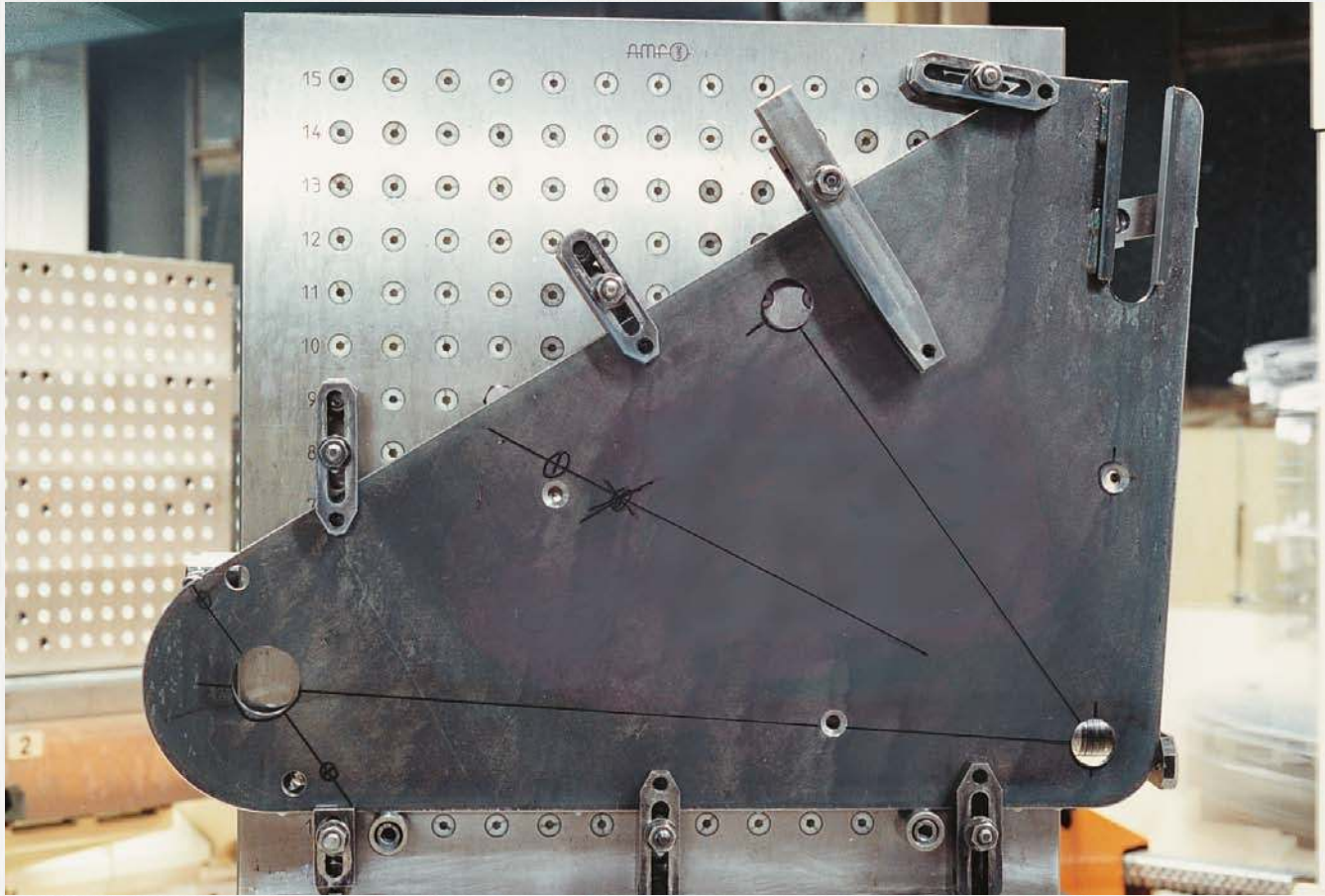

Subject to technical alterations.

## No. 6600

### Eccentric clamp with end clamping

hardened and burnished.



Order no.	Size	H min. [mm]	H max. [mm]	A	B	C	E	L	M	Weight [g]
73502	1	26	35	20	30	37	21-43	100	M12	1000
73510	2	26	35	20	40	45	34-66	125	M16	1400

Eccentric clamps are useful for specialized fixtures.

#### Note:

Actuation by hand - hand force ~ 150 N.

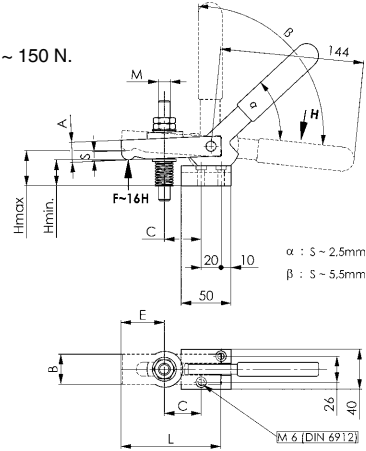

## No. 6601

### Eccentric lever, loose

for end clamping  
(part of 6600)



Order no.	A	B	L	S	Weight [g]
73569	24	14	167	10	300

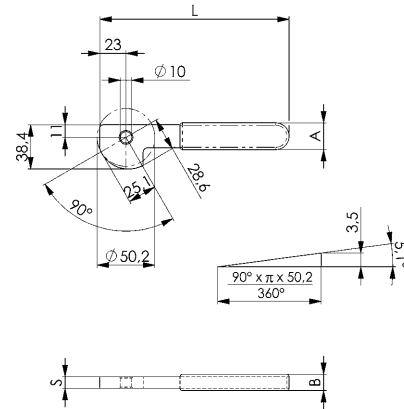

## No. 6610

### Eccentric clamp with middle clamping

hardened and burnished, lever plastic coated.



Order no.	Size	H min. [mm]	H max. [mm]	A	B	C	E	L	M	Weight [g]
73619	1	30	45	20	30	32	21-43	100	M12	1000
73627	2	35	50	20	40	40	34-66	125	M16	1450

#### Note:

Actuation by hand - hand force ~ 150 N.

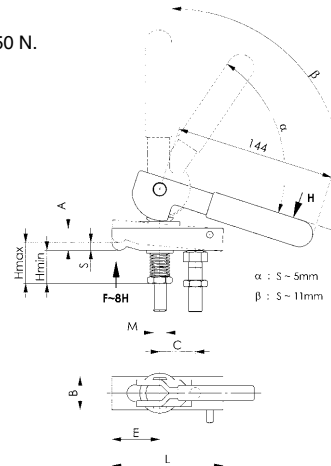

Subject to technical alterations.

## No. 6611

### Eccentric lever, loose

for middle clamping  
(part of 6610)

Order no.	B1	B2	L	Weight [g]
73676	14	14	167	310

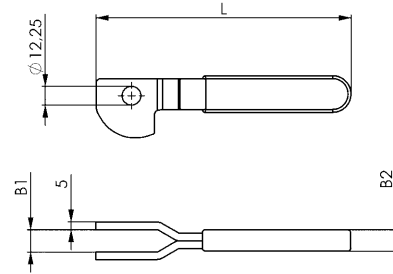

CAD



## No. 6612

### Eccentric lever with eye bolt

(part of 6610)

Order no.	Size	G	H	M	Weight [g]
74500	1	25	110	M12	500
74518	2	30	120	M16	610

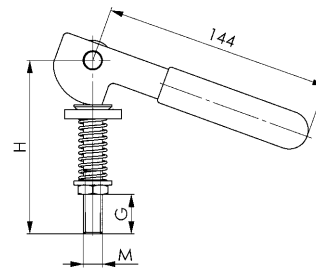

CAD



## No. 6616

### Set screw with nut

(part of 6610)

Order no.	Size	B	L	M	Weight [g]
74542	1	40	58,5	M12	70
74559	2	40	65,0	M16	135

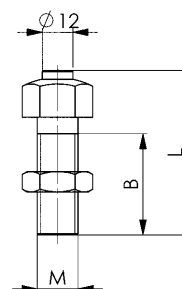

CAD



Subject to technical alterations.

## No. 6383ZEK

### Centring clamp with ball

Can be used from above.  
 Repeatability  $\pm 0.025$  mm  
 Concentricity  $\pm 0.050$  mm



Order no.	D min.	D max.	A min.	A max.	H	P [kN]	Weight [g]
373357	11,7	14,2	3,2	3,9	10,0	0,5	8,2
373365	14,5	18,5	8,6	9,8	14,2	3,5	19
373373	18,5	22,5	10,4	11,6	16,5	4,5	40
373381	22,5	26,5	12,9	14,1	19,6	5,0	73
373399	26,5	30,5	13,0	14,1	19,8	5,0	93
373407	30,5	38,5	11,8	14,1	23,2	5,0	118
373415	38,5	46,5	15,7	18,0	27,2	6,5	249
373423	46,5	54,5	15,7	18,0	27,1	6,5	342
373431	54,5	70,5	19,1	23,7	40,6	8,0	652
373449	70,5	86,5	23,7	28,3	46,1	10,0	1303
373456	86,5	102,5	25,6	30,3	51,2	10,0	1765

### Application:

For centric positioning and clamping in holes, where light ball imprints can be accepted.

### Advantage:

- Low installation height
- Clamping in the zero point
- Pull-down effect
- Distortion-free clamping

### Note:

For deep installation, clearance D max. must be provided.

Installation tool: Retaining pin for determining the precise position of the balls. (supplied without installation tool)

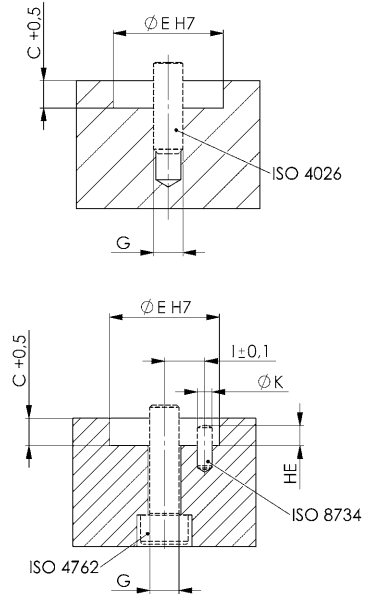
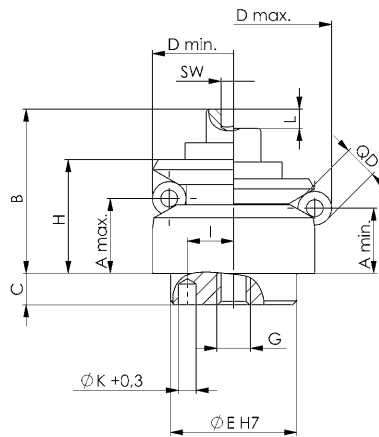

### Dimensions:

Order no.	B	C	E f7	G	HE	I $\pm 0,1$	K	L	Q	QD	SW
373357	14,7	3,5	10	M4	2,0	3,5	1,5	1,3	3	2,5	3
373365	19,2	5,5	12	M4	2,5	4,5	2,0	2,3	3	4,0	3
373373	22,7	7,5	15	M5	3,5	5,5	2,5	2,3	3	4,0	4
373381	28,6	6,0	20	M6	3,5	7,0	3,0	2,3	3	4,0	5
373399	28,8	6,0	20	M6	3,5	7,0	3,0	2,3	3	4,0	5
373407	32,2	7,0	25	M6	3,5	9,0	4,0	4,6	3	8,0	5
373415	39,2	7,5	30	M8	4,5	11,0	4,0	4,6	6	8,0	6
373423	39,2	7,5	30	M8	6,5	11,0	4,0	4,6	6	8,0	6
373431	54,6	9,0	45	M10	6,5	15,0	5,0	9,2	6	16,0	8
373449	63,1	10,0	60	M12	6,5	17,0	5,0	9,2	6	16,0	10
373456	72,2	10,0	60	M16	6,5	25,0	5,0	9,2	6	16,0	14

Q = number of balls

Subject to technical alterations.

## No. 6383ZES

### Centring clamp with protective segments

Can be used from above.  
 Repeatability  $\pm 0.025$  mm  
 Concentricity  $\pm 0.050$  mm



Order no.	D min.	D max.	A min.	A max.	H	P [kN]	Weight [g]
373464	14,5	18,5	8,6	9,8	14,3	3,5	26
373472	18,5	22,5	10,4	11,5	16,6	4,5	45
373480	22,5	26,5	13,0	14,1	19,7	5,0	73
373498	26,5	30,5	13,0	14,2	19,9	5,0	95
373506	30,5	38,5	11,7	14,0	23,2	5,0	131
373514	38,5	46,5	15,5	18,0	27,2	6,5	259
373522	46,5	54,5	15,7	18,0	27,2	6,5	343
373530	54,5	70,5	19,1	23,7	40,7	8,0	675
373548	70,5	86,5	23,6	28,3	46,0	10,0	1347
373555	86,5	102,5	25,6	30,3	51,1	10,0	2099

### Application:

For surface-protecting and centric positioning and clamping in holes.

### Advantage:

- Low installation height
- Clamping in the zero point
- Pull-down effect
- Distortion-free clamping

### Note:

For deep installation, clearance D max. must be provided.

Installation tool: Retaining pin for determining the precise position of the segments. (supplied without installation tool)

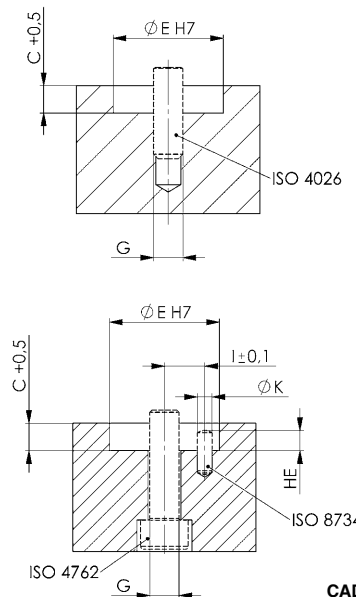
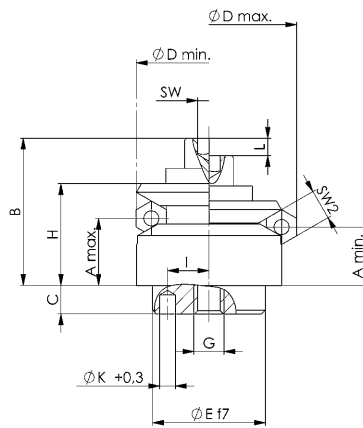

CAD



### Dimensions:

Order no.	B	C	E f7	G	HE	I $\pm 0,1$	K	L	Q	QD	SW	SW2
373464	19,3	5,5	12	M4	2,0	4,5	2,0	2,3	3	4	3	4
373472	22,8	7,5	15	M5	2,5	5,5	2,5	2,3	3	4	4	4
373480	28,7	6,0	20	M6	3,0	7,0	3,0	2,3	3	4	5	4
373498	28,9	6,0	20	M6	3,0	7,0	3,0	2,3	3	4	5	4
373506	32,2	7,0	25	M6	4,0	9,0	4,0	4,6	3	8	5	8
373514	39,2	7,5	30	M8	4,0	11,0	4,0	4,6	6	8	6	8
373522	39,2	7,5	30	M8	4,0	11,0	4,0	4,6	6	8	6	8
373530	54,7	9,0	45	M10	5,0	15,0	5,0	9,2	6	16	8	16
373548	63,0	10,0	60	M12	5,0	17,0	5,0	9,2	6	16	10	16
373555	72,1	10,0	60	M16	5,0	25,0	5,0	9,2	6	16	14	16

Q = number of segments

# THE FIRST STEP FOR USE AND EMPLOYMENT OF SIDE THRUST PIECES:

- > What is being positioned or clamped?
- > Which side thrust pieces will be used?
- > What size corresponds to the workpiece?
- > What tolerance does the workpiece have?
- > How large is the dimension Y? (Workpiece height)
- > How large is the dimension X? (See table)
- > Should the spring deflection be completely used?
- > How is the coordinate dimension determined?

## EXAMPLE: POSITIONING OR CLAMPING A PLATE 100 X 50 X 8 MM

### Should the pin diameter be 5, 6 or 8 mm?

- > If nothing may extend over the plate 5 mm
- > If projection would not be a problem 6 or 8 mm
- > If clamping will be done additionally 6 mm
- > If drilling will be performed without additional clamping 8 mm

### Workpiece height Y?

The tolerance can be ignored

### What force should be selected?

- > For positioning tasks 30 - 60 N
- > For clamping forces 90 - 150 N

### Length / width of the workpiece?

- > Length =  $100 +0/-0.4$  = medium dimension 99,8 mm
- > Width =  $50 +0,2/-0.2$  = medium dimension 50,0 mm

### Dimension X for side thrust pieces with steel spring?

- > See table or formula below

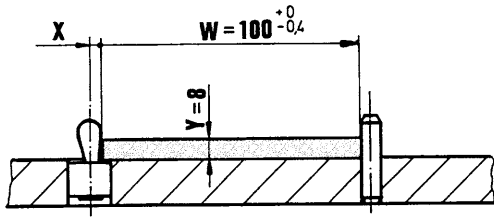

W = workpiece (+/- tolerance)  
- F = pre-tension  
F = (-F) + (+F)

Y = workpiece height  
+ F = clamping force (spring deflection for tolerance)  
T = tolerance

For workpieces that are higher than C minus r, the table values for dimension X or the formula  $X = B/2 - (-F)$  apply.

For workpieces that are smaller than C minus r, the table values for dimension X or the formula  $X = B/2 - (-F) - [(C - r - Y) \times 0,123]$  apply.

Formula for coordinates:

$$K = W - T/2 + x + S/2$$

The table values are standard values that should ideally be checked using a sample clamping.

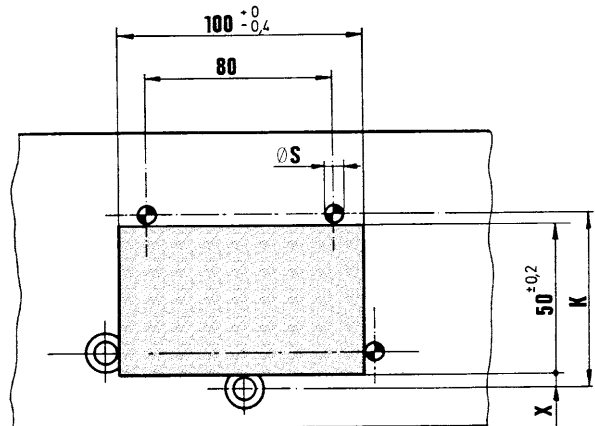
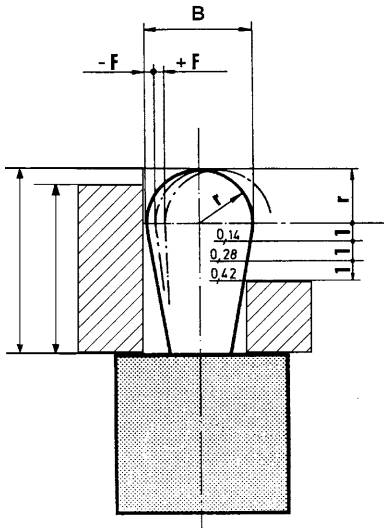

## No. 6380D

### Side thrust piece, with seal

against chips and dirt.

Steel pin for clamping: hardened and galvanised

Sleeve: Aluminium



Order no.	dia. A	B	~P Spring force [N]	C	D-1	ØH H8	F	X	Tool 6380WZ	Weight [g]
373159	6	3	10	4	7	6	±0,5	0,9	03	0,6
373167	6	3	20	4	7	6	±0,5	0,9	03	0,6
373175	6	3	40	4	7	6	±0,5	0,9	03	0,7
373183	10	5	20	6	12	10	±0,8	1,6	05	2,7
373191	10	5	50	6	12	10	±0,8	1,6	05	2,9
373209	10	5	100	6	12	10	±0,8	1,6	05	2,9
373217	10	6	40	10	12	10	±1,0	1,8	06	3,1
373225	10	6	75	10	12	10	±1,0	1,8	06	3,6
373233	10	6	150	10	12	10	±1,0	1,8	06	3,7
373241	12	8	50	13	14	12	±1,3	2,6	08	3,9
373258	12	8	100	13	14	12	±1,3	2,6	08	7,1
373266	12	8	200	13	14	12	±1,3	2,6	08	7,3
373274	16	10	100	16	18	16	±1,6	3,2	10	7,6
373282	16	10	200	16	18	16	±1,6	3,2	10	15
373290	16	10	300	16	18	16	±1,6	3,2	10	15,4

### Note:

With sealing for chip-producing operations with dirt, temperature-resistant up to 150°C.

Sealing: CR, black, 60 Shore. Installation by pressing in.

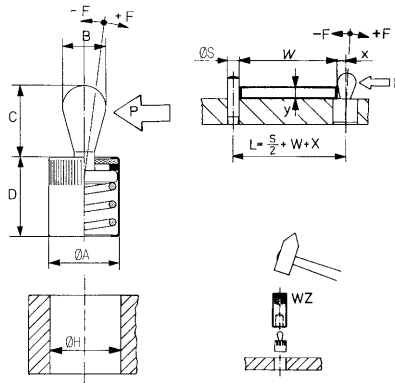

### Recommendations



No. 6380WZ,  
page 166

CAD



Subject to technical alterations.

## No. 6380WZ

### Insertion tool

for pressing in the lateral pressure pad.



Order no.	Size	dia. A	B	Weight [g]
373308	03	8	3,1	16
373316	05/06	12	6,1	19
373332	08	14	8,1	64
373340	10	18	10,2	105

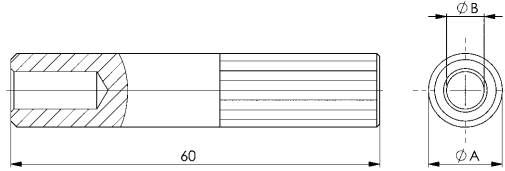

## No. 6387

### Eccentric clamping bolt

clamp in x-y direction with pull down effect.  
Hardened steel 56±1 HRC.



Order no.	dia. A	B	C	D	E	F	G	SW	X	Z	max. holding force [kN]	Md [Nm]	Weight [g]
373779	9,2	M4	3	8	3,0	4,6	4,0	2,5	3,5	4,2	0,09	1,5	2
373787	14,2	M6	5	12	4,5	7,1	6,1	4,0	5,4	6,4	0,3	5,0	6
373795	18,0	M8	6	16	5,5	8,9	7,7	5,0	6,6	8,0	2,7	22,0	9
373803	22,2	M10	7	20	6,5	11,1	9,4	6,0	8,3	9,8	4,0	35,0	16
373811	27,0	M12	9	24	8,0	13,5	11,6	8,0	10,1	12,0	5,4	45,0	31

### Application:

- Clamping above the machining surface
- Clamping below the machining surface
- Clamping in holes.

### Advantage:

- stepless adjustment with eccentric
- high wear resistance.

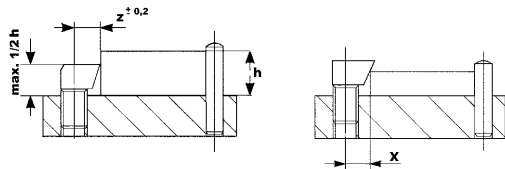
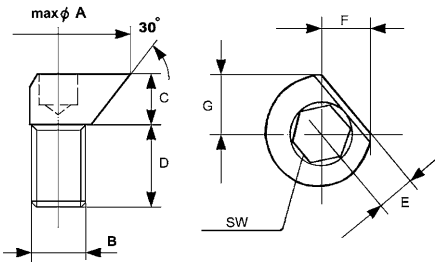

### Clamping above the machining surface

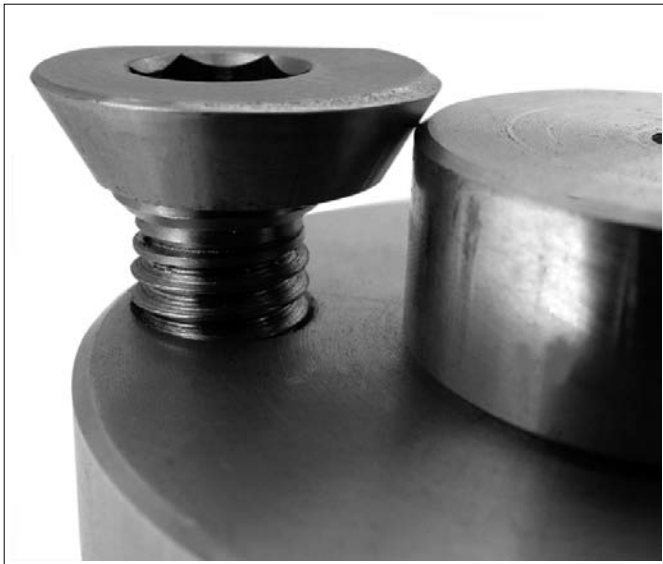

### Clamping below the machining surface



Subject to technical alterations.



## WE DEVELOP THE RIGHT SOLUTION – POTENTIAL SAVINGS BY REDUCING SET-UP TIMES

As a system provider with its own production facility, not only do we have the right product for every need. With many years of experience from all fields of clamping technology we develop the perfect solution for different industries, special projects and for very individual requirements.

With full concentration on a single project, an entire team supports you at AMF, which unites all facets for a successful result.

In close cooperation and with short communication channels, our experienced experts from sales, proposal preparation and purchasing work together with our engineers and designers from the development and production departments.

Thus, we can always ensure that all criteria for a cost-effective production process are met – our specialists look forward to exciting new challenges.

**Just talk to us!**



We will be happy to advise you during your current project .  
**+49 711 5766-2531**



## ... BY ITEM NO.

Article no.	Page	Article no.	Page	Article no.	Page	Article no.	Page	Article no.	Page
DIN 508	104	No. 6321	41	No. 6400M	65	No. 6438S	79	No. 6510	52
DIN 6314	30	No. 6322A	158	No. 6400Z	66	No. 6440	80	No. 6520	115
DIN 6315B	31	No. 6322B	158	No. 6400-285	64	No. 6440G	80	No. 6530	114
DIN 6315C	33	No. 6325	35	No. 6401	69	No. 6440GS	80	No. 6531	114
DIN 6316	33	No. 6328	153	No. 6401AF	71	No. 6441	80	No. 6532	115
DIN 6318	49	No. 6332S	109	No. 6401M	69	No. 6442	81	No. 6535	118
DIN 6319C	112	No. 6333	111	No. 6401MF	71	No. 6442G	82	No. 6600	160
DIN 6319D	112	No. 6333S	110	No. 6401Z	71	No. 6443	81	No. 6601	160
DIN 6319G	113	No. 6333SB	111	No. 6406A-88	70	No. 6444	81	No. 6610	160
DIN 6323	157	No. 6334	107	No. 6406M-88	70	No. 6445	81	No. 6611	161
DIN 6326	52	No. 6339	119	No. 6406-125	72	No. 6460	76	No. 6612	161
DIN 6330B	107	No. 6342	119	No. 6415	74	No. 6465	77	No. 6616	161
DIN 6331	108	No. 6344SP	152	No. 6416	74	No. 6470	116	No. 6621	42
DIN 6340	113	No. 6347	142	No. 6417	84	No. 6470H-1	117	No. 7000	43
DIN 6346	141	No. 6347PP	143	No. 6417Z	85	No. 6470H-2	117	No. 7110DFX-**xM**	47
DIN 6346P	141	No. 6347PS	144	No. 6418	83	No. 6470-Mxx	116	No. 7110DHX-**xM**	47
DIN 6379	100, 101	No. 6347PSP	143	No. 6419	86	No. 6472	135	No. 7110DIX-**xM**	47
DIN 787	94, 95	No. 6348	145	No. 6419B-12-01	87	No. 6472DS	135	No. 7110DKX-**xM**	47
DIN 894	109	No. 6348PP	147, 148	No. 6419B-12-02	87	No. 6485	119	No. 7110DMX-**xM**	45
No. 508F	105	No. 6348PS	149, 150	No. 6419B-12-03	87	No. 6486	122	No. 7110DX-**xM**	45
No. 508L	105	No. 6348PSP	146, 147	No. 6419B-12-04	88	No. 6486AO	121	No. 7110GD-**-1	8
No. 508R	106	No. 6349P	152	No. 6419B-12-05	88	No. 6486AS	121	No. 7110GLX-**-1	45
No. 510	106	No. 6349PP	151	No. 6419B-16-01	88	No. 6490	123	No. 7110GX-**-1	45
No. 6310	28	No. 6350	153	No. 6419B-16-02	89	No. 6491	123	No. 7600	7
No. 6311	29	No. 6351	154	No. 6419B-16-03	89	No. 6492	124	No. 7600BFS	8
No. 6312S	26	No. 6353	154	No. 6419B-16-04	89	No. 6493F	133	No. 7600D	10
No. 6312V	22	No. 6355V	155	No. 6420	75	No. 6493SP	132	No. 7600DGK	10
No. 6312VI	25	No. 6357	156	No. 6425AB	61	No. 6494	127	No. 7600S	9
No. 6312VS	24	No. 6358	156	No. 6425AG	61	No. 6495	138	No. 7600SE	9
No. 6312VT	23	No. 6365	124	No. 6425AGF	61	No. 6495S	138	No. 7600Z	8
No. 6313K	40	No. 6365G	125	No. 6425AP	61	No. 6496	139	No. 7630	12
No. 6314AT	44	No. 6365N	125	No. 6425A-230	60	No. 6496BF	139	No. 7630BFS	13
No. 6314AV	38	No. 6365-**-009	35	No. 6425FB	58	No. 6497	129	No. 7630T	13
No. 6314S	42	No. 6379	102	No. 6425FG	59	No. 6497A	130	No. 7640	14
No. 6314V	36	No. 6379I	102	No. 6425FY	59	No. 6497B	131	No. 7640BFS	20
No. 6314Z	31	No. 6380D	165	No. 6425GA	58	No. 6497F	128	No. 7640D	20
No. 6315GN	32	No. 6380WZ	166	No. 6425MW	62	No. 6498	136	No. 7640Z	15
No. 6315NGG	32	No. 6383ZEK	162	No. 6425S-406	57	No. 6498FR	137	No. 7650	16
No. 6315V	39	No. 6383ZES	163	No. 6425WW	62	No. 6498FT	137	No. 7651	18
No. 6316V	37	No. 6387	166	No. 6425Z	57	No. 6500E	50	No. 787	96-98
No. 6317K	34	No. 6400	65	No. 6425-706	56	No. 6500H	50	No. 797	99
No. 6318B	49	No. 6400FB	67	No. 6430S	78	No. 6501	51		
No. 6319D	112	No. 6400FY	68	No. 6435S	78	No. 6501M	51		

## ... BY ORDER NO.

Order no.	Page	Order no.	Page	Order no.	Page	Order no.	Page	Order no.	Page
120360	125	370049	146	370312	146	370585	147	370858	144
140301	104	370056	146	370320	146	370593	147	370866	144
140327	104	370064	146	370338	146	370601	147	370874	144
153460	104	370072	146	370346	146	370619	147	370882	144
153478	104	370080	146	370353	146	370627	147	370890	144
155630	104	370098	146	370361	146	370635	147	370908	144
158220	106	370106	146	370379	146	370643	147	370916	144
158238	106	370114	146	370387	146	370650	147	370924	144
158246	106	370122	146	370395	146	370668	147	370932	144
158253	106	370130	146	370403	146	370676	147	370940	144
158899	104	370148	146	370411	146	370684	143	370957	144
158907	104	370155	146	370429	146	370692	143	371062	145
159418	104	370163	146	370437	146	370700	143	371070	145
159426	104	370171	146	370445	147	370718	143	371088	145
30064	31	370189	146	370452	147	370726	143	371096	145
3079	31	370197	146	370460	147	370734	143	371104	145
313379	139	370205	146	370478	147	370742	143	371112	145
313395	139	370213	146	370486	147	370759	143	371120	147
313411	139	370221	146	370494	147	370767	143	371138	147
313437	139	370239	146	370502	147	370775	143	371146	147
313452	139	370247	146	370510	147	370783	143	371153	147
313478	139	370254	146	370528	147	370791	143	371161	147
313494	139	370262	146	370536	147	370809	143	371179	147
370007	146	370270	146	370544	147	370817	143	371187	147
370015	146	370288	146	370551	147	370825	144	371195	147
370023	146	370296	146	370569	147	370833	144	371203	147
370031	146	370304	146	370577	147	370841	144	371211	147

**... BY ORDER NO.**

Order no.	Page	Order no.	Page	Order no.	Page	Order no.	Page	Order no.	Page
371229	147	371955	149	372680	151	374181	139	376830	29
371237	147	371963	149	372698	151	374199	139	376863	28
371245	147	371971	149	372706	151	374207	139	376871	28
371252	147	371989	149	372714	151	374215	139	376889	28
371260	147	371997	149	372722	151	374355	136	376897	28
371278	147	<b>372003</b>	149	372730	151	374371	137	376905	28
371286	147	372011	149	372748	151	374397	137	376913	28
371294	147	372029	149	372755	151	374405	36	376921	28
371302	147	372037	149	372763	151	374413	42	376939	28
371310	147	372045	149	372771	151	374439	36	376947	28
371328	148	372052	149	372789	151	374447	47	376962	29
371336	148	372060	149	372797	151	374454	47	<b>377002</b>	29
371344	148	372078	149	372805	151	374462	47	377044	29
371351	148	372086	149	372813	151	374926	23	377069	29
371369	148	372094	149	372821	152	374942	23	<b>381772</b>	110
371377	148	372102	149	372839	152	374967	23	381780	110
371385	148	372110	149	<b>373159</b>	165	374983	23	381798	110
371393	148	372128	149	373167	165	<b>375006</b>	23	381806	110
371401	148	372136	149	373175	165	375501	136	381814	110
371419	148	372144	149	373183	165	375527	137	381822	110
371427	148	372151	149	373191	165	375543	137	381830	110
371435	148	372169	149	373209	165	375592	77	381848	111
371443	148	372177	149	373217	165	375618	77	381855	111
371450	148	372185	149	373225	165	375766	24	381863	111
371468	148	372193	149	373233	165	375782	24	381871	111
371476	148	372201	149	373241	165	375808	24	381889	111
371484	148	372219	149	373258	165	375816	24	381897	111
371492	148	372227	149	373266	165	375824	24	381905	111
371500	148	372235	149	373274	165	375832	24	381913	102
371518	148	372243	148	373282	165	375840	24	381921	111
371526	148	372250	148	373290	165	375857	24	381939	102
371534	148	372268	148	373308	166	375865	24	381954	102
371542	148	372276	148	373316	166	375873	24	381970	102
371559	148	372284	148	373322	166	375881	24	381988	36
371567	150	372292	148	373340	166	375899	24	381996	102
371575	150	372300	148	373357	162	375907	24	<b>382002</b>	36
371583	150	372318	148	373365	162	375915	24	382010	102
371591	150	372326	148	373373	162	375923	24	382028	102
371609	150	372334	148	373381	162	375949	24	382036	102
371617	150	372342	148	373399	162	375956	25	382044	102
371625	150	372359	148	373407	162	375964	24	382051	102
371633	150	372367	148	373415	162	375972	25	382069	102
371641	150	372375	148	373423	162	375980	24	<b>53520</b>	109
371658	150	372383	148	373431	162	375998	25	53579	109
371666	150	372391	148	373449	162	<b>376004</b>	25	53595	109
371674	150	372409	148	373456	162	376012	25	<b>53611</b>	109
371682	150	372417	148	373464	163	376020	25	53629	109
371690	150	372425	148	373472	163	376038	25	53645	109
371708	150	372433	148	373480	163	376046	25	53652	109
371716	150	372441	148	373498	163	376053	25	53660	109
371724	150	372458	148	373506	163	376061	25	53678	109
371732	150	372466	148	373514	163	376079	25	53686	109
371740	150	372474	148	373522	163	376087	25	53694	109
371757	150	372482	152	373530	163	376095	25	<b>53702</b>	109
371765	150	372490	152	373548	163	376103	25	53710	109
371773	150	372508	151	373555	163	376145	32	<b>550509</b>	130
371781	150	372516	151	373779	166	376160	32	550510	130
371799	150	372524	151	373787	166	376186	32	550511	130
371807	149	372532	151	373795	166	376202	32	550512	131
371815	149	372540	151	373803	166	376228	32	550513	131
371823	149	372557	151	373811	166	376244	32	550514	131
371831	149	372565	151	37390	31	376269	32	<b>553351</b>	10
371849	149	372573	151	373928	36	376285	32	553352	10
371856	149	372581	151	373936	36	376301	32	553353	9
371864	149	372599	151	373944	36	376327	32	553441	9
371872	149	372607	151	373951	36	376343	32	553442	10
371880	149	372615	151	373969	51	376475	22	553443	10
371898	149	372623	151	<b>374124</b>	138	376555	28	<b>554198</b>	7
371906	149	372631	151	374132	138	376731	29	554214	9
371914	149	372649	151	374140	138	376756	29	554215	9
371922	149	372656	151	374157	139	376772	29	554216	9
371930	149	372664	151	374165	139	376798	29	554298	8
371948	149	372672	151	374173	139	376814	29	554299	8

**... BY ORDER NO.**

Order no.	Page	Order no.	Page	Order no.	Page	Order no.	Page	Order no.	Page
554300	8	563695	10	70060	30	70847	36	71621	158
554301	10	563697	10	70078	30	70854	36	71639	158
554302	10	563698	10	70086	30	70862	32	71647	158
554821	8	563699	10	70094	30	70870	32	71696	158
554822	8	<b>564074</b>	128	<b>70102</b>	30	70888	32	<b>71704</b>	158
554823	8	564437	122	70110	30	70896	32	71712	158
554824	8	564654	7	70128	30	<b>70904</b>	32	71720	158
554825	8	564665	8	70136	30	70912	32	71738	158
<b>556152</b>	8	564667	10	70151	36	70920	32	71746	158
556153	8	564668	10	70177	36	70938	32	71753	158
556154	8	564669	9	70193	36	70946	32	71761	158
556155	8	564681	8	<b>70201</b>	36	70953	32	71787	122
556156	8	<b>565165</b>	121	70219	36	70961	32	<b>71811</b>	157
556157	8	565320	121	70227	31	70979	32	71829	157
556158	8	565321	121	70235	31	70987	133	71837	157
556159	8	565322	121	70243	31	70995	133	71845	157
556160	8	565323	121	70250	31	<b>71001</b>	133	71852	157
556161	8	565401	121	70268	36	71019	133	71860	157
556162	8	565402	121	70276	36	71027	33	71878	157
556186	7	565403	121	70284	36	71035	33	71886	157
556187	7	565404	121	70292	36	71043	33	71894	157
556188	7	565405	121	<b>70300</b>	36	71050	33	<b>71902</b>	157
556189	7	565580	135	70318	36	71068	33	71910	157
556190	7	565651	135	70326	36	71076	33	71928	122
556406	7	565652	135	70334	31	71084	33	71936	122
556407	8	<b>567981</b>	80	70359	31	71092	33	71944	122
556408	9	567996	14	70367	31	<b>71100</b>	33	71951	122
556409	10	567997	14	70375	31	71118	33	71969	52
556410	10	567998	15	70383	31	71126	33	71977	52
556576	8	567999	20	70391	31	71134	33	71985	52
<b>557186</b>	71	<b>568000</b>	20	<b>70409</b>	31	71159	33	71993	52
<b>558279</b>	142	568020	47	70417	31	71167	39	<b>72009</b>	52
558280	142	568021	47	70425	31	71175	39	72017	52
558281	142	568987	84	70433	31	71183	37	72025	52
558436	71	<b>569378</b>	66	70441	31	71191	39	72033	52
<b>559877</b>	12	569379	66	70458	31	<b>71209</b>	37	72041	52
559879	12	569380	66	70466	31	71217	37	72090	52
559881	12	569381	67	70474	31	71225	37	<b>72108</b>	52
559882	12	569382	67	70482	31	71233	87	72116	52
559909	13	569386	67	70490	31	71258	39	72124	52
559912	13	569387	68	<b>70508</b>	31	71266	37	72132	52
559914	13	569431	64	70516	31	71274	37	72165	141
559915	13	569432	64	70524	31	71282	37	72173	141
559925	13	569433	64	70532	31	71290	37	72181	141
559926	13	569434	61	70540	31	<b>71308</b>	37	72199	141
559930	13	<b>570303</b>	80	70557	31	71316	37	<b>72207</b>	141
559931	13	<b>571087</b>	122	70565	31	71324	37	72215	141
<b>562000</b>	56	571088	9	70573	31	71332	37	72223	141
562001	60	571089	9	70581	31	71340	34	72231	141
562002	57	571090	9	70599	31	71357	34	72249	141
562003	57	571091	9	<b>70607</b>	31	71365	49	72256	141
562004	57	571092	9	70615	31	71373	49	72264	141
562005	58	571093	9	70623	31	71381	49	72272	141
562006	59	571094	9	70631	31	71399	49	72280	141
562007	59	571389	135	70649	31	<b>71407</b>	49	72298	141
562008	58	571391	135	70656	31	71415	49	<b>72306</b>	141
562009	58	571392	135	70672	31	71423	49	72314	141
562010	58	<b>572092</b>	7	70680	132	71449	122	72322	141
562011	61	572093	8	70698	132	71456	122	72330	141
562012	61	572511	16	<b>70706</b>	33	71464	122	72348	141
562013	61	572512	16	70714	33	71472	122	72355	141
562014	62	572513	16	70722	33	71480	49	72363	141
562015	62	572514	16	70730	33	71498	49	72371	72
562016	128	572515	18	70748	33	<b>71506</b>	49	72389	65
562017	128	572516	18	70755	33	71522	41	72397	65
562018	128	572517	18	70763	33	71530	41	<b>72405</b>	65
562125	82	572518	18	70771	33	71555	158	72413	65
562155	57	<b>70003</b>	30	70789	33	71563	158	72421	65
562184	7	70011	30	70797	33	71571	158	72439	65
562185	8	70029	30	<b>70805</b>	33	71589	158	72447	65
562186	8	70037	30	70813	33	71597	158	72454	81
<b>563656</b>	7	70045	30	70821	36	<b>71605</b>	87	72496	65
563658	8	70052	30	70839	36	71613	158	<b>72520</b>	116

**... BY ORDER NO.**

Order no.	Page	Order no.	Page	Order no.	Page	Order no.	Page	Order no.	Page
72546	75	73445	42	74377	154	75473	143	80002	104
72553	78	73452	42	74385	154	75481	143	80010	104
72561	78	73460	42	<b>74450</b>	154	75499	143	80028	104
72579	78	73478	42	74468	154	<b>75507</b>	143	80036	104
72587	78	<b>73502</b>	160	<b>74500</b>	161	75515	143	80044	104
<b>72637</b>	78	73510	160	74518	161	75523	143	80051	104
72645	78	73528	45	74542	161	75531	143	80069	104
72652	78	73536	45	74559	161	75549	143	80077	104
72660	78	73544	45	74567	38	75556	143	80085	104
<b>72710</b>	80	73551	45	74575	38	75564	143	80093	104
72728	80	73569	160	74583	38	75572	143	<b>80101</b>	104
72736	81	73577	45	74591	38	75580	143	80119	104
72744	81	73585	45	<b>74609</b>	42	<b>75606</b>	145	80127	104
72751	81	73593	45	74617	42	75614	145	80135	104
72769	80	<b>73601</b>	45	74625	38	75622	86	80143	104
72777	76	73619	160	74633	38	75630	89	80150	104
72785	76	73627	160	74641	38	75648	145	80168	104
72793	76	73635	45	74658	38	75655	156	80176	104
<b>72801</b>	36	73643	45	74666	38	75663	156	80184	104
72819	81	73650	47	74674	116	<b>75705</b>	79	80192	104
72827	36	73668	47	74682	35	75713	79	<b>80200</b>	104
72850	70	73676	161	74690	35	75721	79	80218	104
72868	70	73684	47	<b>74716</b>	43	75754	86	80226	104
72876	71	73692	47	74724	43	75770	69	80234	104
72884	71	<b>73718</b>	47	74732	43	75788	69	80242	104
72892	119	73726	47	74740	43	75796	69	80259	106
<b>72900</b>	119	73734	47	74765	43	<b>75804</b>	69	80267	106
72918	119	73742	47	74773	43	75812	69	80275	106
72926	71	73759	47	74781	43	75820	69	80283	106
72942	36	73767	47	74799	43	75879	156	80291	106
72959	123	73775	47	<b>74807</b>	43	75895	156	<b>80309</b>	106
72967	123	73783	47	74815	43	<b>75903</b>	156	80317	106
72975	123	<b>73817</b>	123	74831	43	75911	156	80325	106
72983	123	73825	123	74849	43	75952	119	80333	106
72991	123	73833	123	74856	43	75960	119	80341	106
<b>73007</b>	123	73841	123	74880	116	75978	119	80358	104
73015	123	73858	123	<b>74906</b>	41	75986	119	80366	104
73023	123	73866	123	74914	41	75994	119	80374	94
73031	123	73874	123	74922	41	<b>77149</b>	40	80382	94
73056	36	73882	123	74930	41	77156	40	80390	94
73064	36	73890	136	74963	41	77180	40	<b>80408</b>	94
73072	36	<b>73908</b>	137	74971	41	77198	40	80416	94
73080	124	73916	137	74997	43	<b>77206</b>	40	80424	94
73098	124	73932	40	<b>75002</b>	43	<b>77834</b>	138	80432	94
<b>73106</b>	124	73940	40	75010	43	<b>78626</b>	35	80440	94
73114	124	73957	40	75028	43	78667	35	80457	94
73122	124	73965	40	75051	88	<b>78907</b>	138	80465	94
73130	127	73973	40	75085	155	78956	8, 34	80473	94
73148	127	73981	44	75093	155	78972	8, 34	80481	94
73155	127	73999	44	<b>75150</b>	153	<b>79186</b>	138	80499	94
73189	39	<b>74039</b>	42	75168	153	79194	44	<b>80507</b>	94
73197	39	74047	42	75176	153	<b>79210</b>	23	80515	94
<b>73205</b>	39	74054	42	75192	153	79228	23	80523	94
73213	129	74062	42	<b>75200</b>	153	<b>79392</b>	124	80531	94
73221	129	<b>74179</b>	84	75218	153	<b>79749</b>	26	80549	94
73239	129	74187	117	75226	153	79756	22	80556	94
73247	39	74195	85	75234	153	79764	26	80564	94
73254	39	<b>74203</b>	117	75242	153	79772	26	80572	94
73262	39	74211	85	75259	153	79780	23	80580	94
73270	116	74229	87	75267	153	79798	22	80598	94
73288	39	74245	88	75275	153	<b>79806</b>	23	<b>80606</b>	94
73296	50	74252	116	75283	143	79814	26	80614	94
<b>73304</b>	50	74260	153	75291	143	79822	23	80622	94
73312	50	74278	153	<b>75309</b>	141	79830	26	80630	94
73320	65	74286	153	75317	141	79848	23	80648	94
73346	50	74294	153	75325	141	79855	22	80655	94
73353	51	<b>74302</b>	153	75333	141	79863	23	80663	94
73361	65	74310	153	75341	141	79871	26	80671	94
73379	52	74328	153	75382	88	79889	23	80689	94
73387	52	74336	153	<b>75416</b>	83	79897	26	80697	94
73395	52	74344	153	75424	89	<b>79905</b>	23	<b>80705</b>	94
<b>73403</b>	65	74351	153	75432	47	79913	22	80713	94
73437	42	74369	154	75440	89	79921	23	80721	94

## ... BY ORDER NO.

Order no.	Page	Order no.	Page	Order no.	Page	Order no.	Page	Order no.	Page
80739	94	81521	100	<b>82305</b>	107	83063	115	84665	105
80747	94	81539	100	82313	108	83071	118	84673	105
80754	94	81547	96	82321	107	<b>83089</b>	118	84681	105
80770	94	81562	96	82339	107	<b>83105</b>	118	84699	105
80788	94	81570	100	82347	107	<b>83584</b>	114	<b>84707</b>	105
80796	94	81588	96	82354	107	83592	114	84715	105
<b>80804</b>	94	81596	100	82362	107	<b>83600</b>	114	84723	105
80812	96	<b>81604</b>	96	82370	107	83618	114	84731	106
80820	96	81612	100	82388	107	83626	114	84749	105
80838	96	81620	100	82396	107	83642	114	84756	100
80846	96	81638	100	<b>82404</b>	107	83691	114	84764	105
80853	96	81646	100	82412	107	<b>83808</b>	114	84772	100
80861	96	81653	100	82420	107	83816	114	84780	100
80879	96	81661	100	82438	107	83824	114	84798	100
80887	96	81679	100	82446	107	83832	114	<b>84806</b>	100
80895	96	81695	100	82453	107	83840	114	84814	100
<b>80903</b>	96	<b>81703</b>	100	82461	107	83899	115	84822	100
80911	96	81711	100	82479	107	<b>83907</b>	115	84830	100
80929	96	81737	112	82487	107	83915	115	84848	100
80937	96	81745	112	82495	107	83923	98	84855	100
80945	96	81752	112	<b>82503</b>	107	83956	98	84863	100
80952	96	81760	112	82511	108	83972	98	84871	100
80960	96	81778	112	82529	108	83998	98	84889	100
80978	96	81786	112	82537	108	<b>84004</b>	94	84897	100
80986	96	81794	112	82545	108	84012	94	<b>84905</b>	100
80994	96	<b>81802</b>	112	82552	108	84038	94	84913	100
<b>81000</b>	96	81810	112	82560	108	84046	94	84921	100
81018	96	81828	112	82578	108	84053	94	84939	100
81026	96	81836	112	82586	108	84061	94	84947	100
81034	96	81844	112	82594	108	84079	94	84954	100
81042	96	81851	94	<b>82602</b>	108	84087	94	84962	100
81059	96	81869	112	82610	108	<b>84103</b>	94	84970	100
81067	96	81877	112	82628	108	84111	94	84988	100
81075	96	81885	112	82636	108	84129	94	84996	100
81083	96	81893	112	82644	108	84137	94	<b>85001</b>	100
81091	96	<b>81901</b>	112	82651	107	84152	94	85019	100
<b>81109</b>	96	81919	112	82669	107	84160	94	85027	100
81117	96	81927	112	82677	107	84186	96	85035	100
81125	96	81935	112	82685	107	84194	96	85043	100
81133	96	81943	112	82693	107	<b>84202</b>	96	85050	100
81141	96	81950	112	<b>82701</b>	107	84210	96	85068	100
81158	96	81968	112	82719	107	84236	96	85076	100
81166	96	81976	112	82727	107	84244	96	85084	100
81174	96	81984	113	82735	107	<b>84301</b>	96	85092	100
81182	96	81992	113	82743	107	84319	96	<b>85472</b>	100
81190	96	<b>82008</b>	113	82750	107	84327	96	85480	100
<b>81216</b>	96	82016	113	82768	107	84335	96	85498	100
81224	96	82024	113	82776	107	84376	96	<b>85506</b>	100
81232	96	82032	113	82784	107	84384	94	85514	100
81240	96	82040	113	82792	107	84392	96	85522	100
81257	100	82057	113	<b>82800</b>	108	<b>84400</b>	94	85548	100
81265	104	82065	113	82818	113	84418	96	85555	100
81273	100	82073	113	82826	113	84426	94	85563	100
81281	98	82081	113	82834	113	84434	94	85571	102
81299	100	82099	113	82842	113	84442	96	85589	100
<b>81315</b>	100	<b>82107</b>	108	82859	113	84459	96	<b>85605</b>	94
81323	94	82115	108	82867	113	84467	100	85613	94
81331	100	82123	102	82875	113	84475	100	85621	94
81349	100	82149	108	82883	113	84483	106	85639	94
81356	96	82156	108	82891	113	84491	106	85647	94
81364	98	82164	108	<b>82909</b>	113	<b>84509</b>	106	85654	94
81372	100	82172	108	82917	113	84517	106	85662	94
81380	100	82180	102	82925	113	84525	106	85670	94
81398	100	82198	108	82933	113	84533	106	85688	94
<b>81406</b>	94	<b>82206</b>	108	82941	113	84541	106	85696	94
81414	100	82214	108	82958	113	84558	106	<b>85704</b>	94
81422	100	82222	108	82966	94	84566	106	85712	94
81448	96	82230	108	82974	96	84574	106	85720	94
81463	98	82248	108	82982	115	84582	106	85738	94
81471	100	82255	108	82990	115	84590	106	85746	96
81489	100	82263	102	<b>83006</b>	115	<b>84608</b>	106	85753	96
81497	94	82271	107	83014	115	84632	106	85761	96
<b>81505</b>	96	82289	107	83030	115	84640	105	85779	96
81513	100	82297	107	83055	115	84657	105	85787	96

**... BY ORDER NO.**

Order no.	Page	Order no.	Page	Order no.	Page	Order no.	Page	Order no.	Page
85795	96	86231	98	86512	74	87338	99	88286	102
85803	96	86256	98	86520	74	87346	98	88492	124
85811	96	86264	98	86538	74	87353	99	88500	125
85829	94	86272	98	86546	100	87361	98	88526	125
85837	96	86280	98	86553	100	87379	99	88534	109
85845	94	86298	98	86561	100	87395	99	88542	125
85852	96	86306	98	86579	100	87403	98	88559	109
85860	96	86314	98	86587	100	87411	106	88567	109
85878	96	86322	98	86595	100	87429	98	88575	109
85886	96	86330	98	86611	98	87437	98	88583	109
85894	96	86348	98	86629	98	87445	98	88930	102
85902	96	86355	98	86645	98	87510	98	89094	102
85910	96	86363	98	86678	98	87577	98	89136	102
85928	100	86371	98	86686	119	87585	98	89151	102
85977	100	86389	98	86793	99	87643	94	89177	102
85993	106	86397	98	86801	99	87668	102	89193	102
86009	100	86405	98	86819	99	87684	102	89250	102
86025	100	86413	98	86959	99	87692	102	89276	102
86041	100	86421	98	87114	99	87700	102	89730	105
86140	98	86439	98	87171	112	87734	102	89748	105
86157	98	86447	98	87197	112	87742	102	89763	105
86165	98	86454	98	87239	112	87759	102	89771	105
86173	98	86462	98	87254	112	87783	94	89839	105
86181	98	86470	98	87296	99	87791	102	89904	105
86199	98	86488	98	87304	98	87833	102		
86207	98	86496	98	87312	99	88146	109		
86215	98	86504	74	87320	98	88153	106		

**... IN ALPHABETICAL ORDER**

Description	Page	Description	Page
<b>A</b>		Clamp „light design“, with adjustable support screw, complete	29
Aluminium base for screw jacks	71	Clamp, short, with U-piece	40
Aluminium screw jack	69	Clamp, short, with U-piece, complete	40
Aluminium screw jack with chip guard plate and aluminium base	70	Clamp, straight	45
Aluminium screw jack with chip guard plate and magnetic base	70	Clamp, straight (long)	45
Aluminium screw jack with magnetic base	69	Clamp with nose, closed	32
Aluminium screw jack with swarf protection	72	Clamp with plastic cap	28
Aluminium spacer element	71	Clamp with plastic cap, complete	28
AMF-TWINNUT nut - with collar	111	Clamping element, horizontal	132
AMF-TWINNUT nut - without collar	110	Clamping jaw	87, 88, 89, 131
Atlas screw jack with counter nut	78	Clamping Jaws, serrated	125
<b>B</b>		Clamping Jaws, with ridge	125
Ball pressure screw	9	Clamping unit to clamp outside of the tool table	44
Ball pressure screw with hexagon head for power clamp	9	Clamps for machine vices	35
Ball-pad	80	Compact clamp	14
Base element	58, 59, 67	Conical sockets, tempered	112
Base element slot	68	Cranked clamp with adjusting support screw	37
Base plate, round	137	Cranked clamp with adjusting support screw, complete	37
Base plate with groove	137	„	
Basic sortiment	115	„Crocodile“ clamp	22
Bearing, point	61	„Crocodile“ clamp, complete with DIN 6379	24
Bearing, smooth	61	„Crocodile“ clamp, complete with DIN 787	23
Bearing, smooth, fixed	61	„Crocodile“ clamp, complete with no. 6379I	25
Bearing, spherical	61	<b>C</b>	
Blanks for T-nuts	106	Cylindrical stop	153
Bolts for T-slots	94, 95	<b>D</b>	
Bolts for T-slots, complete	96, 97	Detent clamp lever	42
Boxed set of assorted clamping elements	114	Dished washer	112, 113
<b>C</b>		<b>E</b>	
Carrier element 3-step	13	Eccentric clamp with end clamping	160
Centering-pad	81	Eccentric clamp with middle clamping	160
Centring clamp with ball	162	Eccentric clamping bolt	166
Centring clamp with protective segments	163	Eccentric lever, loose	160, 161
Centring plate with thread	82	Eccentric lever with eye bolt	161
Clamp, continuously adjustable	41	Edge Clamp	136
Clamp, continuously adjustable, complete	41	Elongation nuts (3.0 d high)	107
Clamp, cranked	33	Extra strong clamping jaw	129
Clamp, double	35	<b>F</b>	
Clamp, double (short)	8, 34	Fastening bolt for T-slot clamp	138
Clamp, flat	30	Fastening kit for carrier element 3-step	13
Clamp, „light design“	29		

**... IN ALPHABETICAL ORDER**

Description	Page
Fixed type tenons	158
Flat clamp	139
Flat clamp, model „Mini-Bulle“	124
Floating clamp	86
Forked clamp tapered	31
Forked clamp with pin end	33
Forked clamp with shoe	32
<b>H</b>	
Heavy duty thread paste	119
Heavy screw jack	78
Height adjustment jack with fine thread and base element 6425FB	60
Height setting screw jack	74
Height setting screw jack with magnetic base	74
Height setting screw jack with pivotable ball	75
Hexagon nuts (1.5 d high)	107
Hexagonal nuts with collar (1.5 d high)	108
Holder for clamping bolts	117
Holder for clamps	117
<b>I</b>	
Insertion tool	62, 166
<b>L</b>	
Locating-pad	81
Loose type tenons	157
Low height clamping jaws, model „Bulle“	123
Low height clamping jaws, model „Maxi-Bulle“	127
Low type tenons	158
<b>M</b>	
Magnetic base for screw jacks	71
Mandrel	84
Mounting key	111
Mounting kit	8, 20
Mounting kit for flat clamp	139
<b>N</b>	
Nuts for T-slots, extended	105
Nuts for T-slots „Rhombus“	106
Nuts for T-slots (T-nuts)	104
<b>O</b>	
Open-ended spanner, single-ended	109
<b>P</b>	
Parallel stop	154
Parallel stops in pairs	153
Parallel support set in wooden box	142
Parallel support set in wooden stand	145
Parallel supports-pairs	141
Parallel supports-pairs, precision	143, 151, 152
Parallel supports-pairs, precision, 100 mm long	147
Parallel supports-pairs, precision, 125 mm long	148
Parallel supports-pairs, precision, 150 mm long	148
Parallel supports-pairs, standard	144
Parallel supports-pairs, standard, 100 mm long	149
Parallel supports-pairs, standard, 125 mm long	149
Parallel supports-pairs, standard, 150 mm long	150
Parallel supports-pairs, super-precision	143
Parallel supports-pairs, super-precision, 100 mm long	146
Parallel supports-pairs, super-precision, 125 mm long	146
Parallel supports-pairs, super-precision, 150 mm long	147
Parallel supports-set	141
Parallel supports-set, corrugated	152
Power clamp	7
Power clamp 3-step	12
Precision angle stop	154
Precision wedge block	77
Pressure pad	10
Prismatic clamping block	155
Pull-Down Clamp	124
<b>Q</b>	
Quick-action clamping nut without collar	109
<b>R</b>	
Rhombus-head screws for T-slots	99
<b>S</b>	
Screw jack element with acme thread and base element 6425FB	57
Screw jack, modular	56
Screw jack, quick-action	79

Description	Page
Screw jack set	64
Screw jack with flat support	65
Screw jack with flat support and magnetic base	65
Screws for T-slot, strength class 12.9	98
Serrated heel block	52
Set of assorted plastic clamping elements	118
Set screw	45
Set screw, brass	45
Set screw with ball	47
Set screw with ball, plain	47
Set screw with clamping point for side clamp	135
Set screw with flat-faced ball, ribbed	47
Set screw with nut	161
Side clamp with clamping point	135
Side stop	156
Side thrust piece, with seal	165
Slot stop	123
Solid clamping jaws, flat design	128
Spacer element	8, 57, 66, 85
Spacer element with quick-action clip	15
Spherical attachment with thread	80
Spherical seat washer	112
Spring type clamp support	119
Step block	51
Step blocks	49
Step blocks, wide	49
Step clamp	31, 43
Stepped clamp with adjusting support screw	38, 39
Stepped clamp with adjusting support screw, complete	38, 39
Stop, adjustable	156
Stop, fixed	130, 133
Studs for nuts and T-slots	100, 101
Studs for nuts and T-slots, strength class 12.9	102
Studs with hexagon socket, strength class 12.9	102
Support block with magnet	51
Support blocks for continuous adjustment, combination	52
Support blocks for continuous adjustment, single	52
Support element, mechanical	83
Support extension	26
Support screw	42
Support with pivotable ball	81
Swing clamp, mechanical	16
Swing clamp, mechanical, modular	18
Swivelling attachment smooth with +/- 3° angle function	80
<b>T</b>	
Tapered clamp with adjusting support screw	36
Tapered clamp with adjusting support screw, complete	36
T-bolt set	115
Thread adapter	58
Thrust piece plastic (plain)	10
Thrust piece set	20
T-nuts with spring	105
Tool cart	62
Trolley for clamping equipment	116
Trolley for clamping equipment with basic set of clamping equipment	116
T-slot clamp	138
T-slot cover	122
T-slot scraper	119
T-slot side cover	121
<b>U</b>	
Universal step block set	50
Universal step blocks	50
<b>V</b>	
Vee-pad	80
<b>W</b>	
Washers for clamping tools	113
Wedge block „Herkules“ height wedge	76

These Terms of Payment apply for companies, legal entities governed by public law and public law special funds. Our goods and services are supplied exclusively on the basis of the following conditions. Any deviating purchasing conditions of the customer not expressly recognised by us will not become part of the contract through acceptance of the order. By placing the order and accepting the goods we deliver, the customer confirms its consent to our terms and conditions.

## 1. Offer and contractual conclusion

All our offers are always subject to change without notice unless otherwise explicitly agreed. Our delivery contracts are based on the latest version of our catalogue. Dimension and weight values, as well as illustrations, drawings and data, are non-binding and can be changed by us at any time. Therefore, deviations cannot be ruled out and do not justify any compensation claims against us.

Orders are considered accepted only when confirmed by us in writing. If, for organisational reasons, the customer does not receive a separate confirmation upon the delivery of goods, the invoice shall also be deemed the order confirmation.

## 2. Prices

The prices are in EURO, ex-works, excluding VAT, packing, freight, postage and insurance. Unless otherwise agreed, our list prices valid on the day of delivery shall apply. For orders below 50 EUR goods net, we must make a minimum quantity surcharge of a 20 EURO for cost reasons.

## 3. Tool costs

Unless any other agreements have been reached, the tools fabricated for the purpose of executing the order shall remain our property in all cases, even if we have invoiced a tool cost component separately.

## 4. Payment

Unless otherwise stated on the invoice, the purchase price falls due for net payment within 30 days of the invoice date (without deduction of discount). Invoice amounts of below 50 EURO are due for payment immediately.

In case of payment default, we shall be entitled to charge default interest. The amount corresponds to our interest rate for current account credits at our main bank; the minimum however being 8 percentage points above the relevant base interest rate applied by the European Central Bank. Moreover, in case of default following written notice to the customer, we shall be entitled to cease to fulfil our obligations until payments are received.

## 5. No set-off

The customer can set-off only with legally confirmed or undisputed counterclaims.

## 6. Right of withdrawal in case of delayed acceptance or payment and insolvency

If the customer fails to accept the goods in due time, we shall be entitled to set a reasonable period of grace, after which we can dispose of the goods elsewhere and supply the customer on a reasonably longer term. Our rights to withdraw from the contract under the provisions of Section 326 BGB and demand damages for non-performance shall not be affected. If the customer fails to pay for the goods once payment is due, we shall be entitled, at the end of a reasonable period of grace we have set, to withdraw from the contract and demand the return of any goods already supplied. Section 323 BGB remains unaffected in all other cases.

If the customer applies for the opening of insolvency proceedings, we shall be entitled, prior to the ordering of security measures by the insolvency court, to withdraw from the contract and demand the immediate return of the goods.

## 7. Customer-specific fabrications/project fabrications (custom fabrications)

Customer-specific fabrications require binding information on design, quantity etc. in written form at the time of ordering. For manufacturing reasons, we reserve the right to supply up to 10% above or below the order quantity. Technical modifications or cancellations are subject to any costs incurred. The return of customer-specific fabrications is impossible.

## 8. Delivery and packaging, transfer of risk

The delivery date is non-binding; although stated to the best of our knowledge. It is subject to us receiving correct, defect-free and complete deliveries. The stated delivery dates relate to completion in the factory, starting on the day the order is accepted by us. Delivery is EXW (ex-works) in accordance with Incoterms 2020. Therefore, the costs are borne by the customer. The risk is transferred to the customer when the goods are passed to the person, company or facility nominated to execute the shipment. This applies also for partial deliveries, or if we have assumed responsibility for delivery and installation. The risk shall be transferred to the customer even in the case of delayed acceptance.

In the absence of specific shipping instructions, we shall proceed as we deem fit and without any obligation to the cheapest or most expedient method. The customer agrees that the order can also be delivered in parts, insofar as this is reasonable for the customer. We shall charge a 10 EURO processing fee for shipping to third parties that we supply on behalf of the customer.

The packaging complies with the packaging ordinance. Disposable packaging shall be charged at cost price. The packaging cannot be taken back.

## 9. Performance impediment and/or impossibility

If we are hindered in the fulfilment of our obligation due to the onset of unforeseeable circumstances, which we are unable to avoid despite reasonable effort in relation to the nature of the circumstances (e.g. operational interruption, delay in the delivery of important raw materials, defects in the delivery), the delivery time shall be extended by a reasonable period, insofar as the supply of goods or services is not rendered unreasonably difficult or impossible.

If we have to accept that these circumstances are not only temporary, we shall be entitled to withdraw from the contract either in whole or in part.

If the supply of goods or services becomes impossible, the customer shall not be obliged to furnish its own contractual service. Section 275 BGB applies mutatis mutandis. If, however, the customer is solely or predominantly responsible for the

circumstances that led to impossibility, it shall remain under an obligation to render the return service. The same applies if this circumstance occurs at a time when the customer is behind schedule with acceptance.

## 10. Samples/returns

Samples shall be provided only against payment. If samples or models are provided, a credit note shall be issued with the subsequent order if the order value is 125 EURO net or more. Goods can be returned only by agreement, although custom fabrications are excluded from such return.

In the case of returns for which we are not responsible (e.g. incorrect order), we shall charge a processing fee of 10%, the minimum value, however, being 7.50 EURO.

## 11. Retention of title

The goods shall remain our property unless full payment of all claims and/or until the cheques provided for this purpose are honoured. The itemisation of claims in an ongoing invoice, as well as balancing the account and the recognition thereof does not affect the retention of title. The customer is entitled to sell on the retained goods during the ordinary course of business. However, the customer is not permitted to pledge the goods or transfer them by way of security. It shall assign its claim ensuing from the selling on of the retained goods to us in advance. The customer shall be entitled to collect the claim to the extent that it has fulfilled its obligations towards us. At our request, the customer shall be obliged to state third-party debtors and we shall be entitled to report this and the assignment.

## 12. Property rights

We reserve property rights and copyrights to all contractual documents such as drafts, drawings, calculations and cost estimates. Such documents must not be reproduced or disclosed to third parties without our consent. Any rights to patents, utility models etc. reside solely with us, insofar as such patents have not yet been filed. Our products are allowed to be replicated only with our written consent.

If objects are fabricated according to drawings or samples, the customer shall warrant that any third party property rights are not infringed by manufacture or delivery. If a third party forbids manufacture and delivery on account of property rights, we shall be entitled to stop manufacture and delivery immediately. The customer shall be obliged to reimburse us with all costs incurred and indemnify us from third party compensation claims. Compensation claims by the customer are impossible.

## 13. Warranty

If the customer agrees with us a particular quality of the goods, we shall base this agreement on our technical delivery specifications. If we have to deliver according to customer drawings, specifications, samples etc., the customer shall assume the risk for suitability for the intended purpose. If, after the contract is concluded, the scope of goods or services is changed at the customer's request and this impairs the quality or suitability of the goods, claims for defects on the part of the customer shall be ruled out, insofar as such impairments are caused by the customer's requests for change. The time at which the risk is transferred is decisive for the contractual state of the goods. Wear and tear of wearing parts caused by ordinary use does not constitute a defect. Claims for defects are ruled out in the following cases in particular: Unsuitable or improper use, incorrect installation and/or commissioning by the customer or third party, normal wear and tear, incorrect or negligent handling - in particular excessive use -, unsuitable equipment, replacement materials, chemical, electrochemical or electrical influences, unless such defects are caused by ourselves.

If the goods contain a defects, we shall provide, following a reasonable period of grace set by the customer, either a replacement or a repair as we deem fit. If such subsequent performance fails, the customer shall be entitled to either reduce the purchase price or withdraw from the contract. Any further warranty claims are ruled out. In case of negligible deviations from the agreed quality, no claims for defects shall be recognised.

The discovery of defects must be communicated to us immediately in writing. In the case of recognisable defects, however, within 10 days of acceptance, in the case of non-recognisable defects immediately after they become evident. The warranty is 12 months, starting with delivery of the goods ex-works.

## 14. Liability

With the exception of harm to life, body or health on account of a breach of duty by ourselves, our liability shall be limited to intent or gross negligence.

## 15. Place of fulfilment, place of jurisdiction and governing law

The place of fulfilment for all obligations ensuing from this contractual relationship is D-70734 Fellbach.

The place of jurisdiction for all legal disputes ensuing from the contractual relationship is the court responsible for the headquarters of Andreas Maier GmbH & Co. KG.

All disputes ensuing from the contract or regarding the validity thereof shall be finally decided by a court of arbitration in accordance with the Court of Arbitration Ordinance of the German Committee for Arbitration Court Procedures or the Conciliation and Arbitration Arrangement of the International Chamber of Commerce, recourse to ordinary courts of law being excluded. The legal dunning process, however, remains permissible.

German law shall govern (BGB and HGB). The applicability of the UN Convention on Contracts for the International Sale of Goods (CISG) is ruled out.

## 16. Severability clause

If individual provisions become legally invalid, the remaining provisions shall not be affected. The legally invalid provision shall be replaced by regulations that most closely reflect the economic purpose of the contract with reasonable consideration for the mutual interests. The publication of these Terms of Sale, Delivery and Payment renders all previous versions invalid. This does not apply for any contracts concluded prior to announcement.

# STANDARD CLAMPING ELEMENTS **CATALOGUE 2026**

Request additional catalogues from [www.amf.de](http://www.amf.de)



ZERO-POINT-SYSTEMS



HYDRAULIC CLAMPING SYSTEMS



VACUUM CLAMPING SYSTEMS

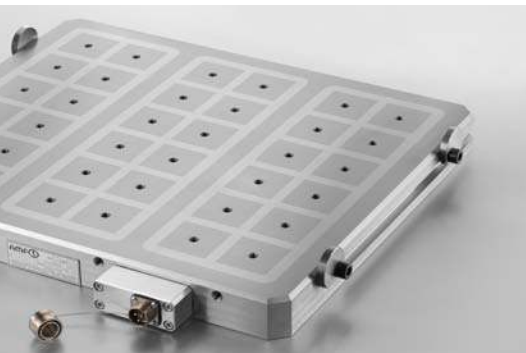

MAGNETIC CLAMPING SYSTEMS



WIRELESS SENSING SYSTEMS



TOGGLE CLAMPS



SINGLE AND MULTIPLE CLAMPING SYSTEMS



STANDARD CLAMPING ELEMENTS



MARKING AND CLEANING TOOLS



**ANDREAS MAIER GmbH & Co. KG**

Waiblinger Straße 116 · D-70734 Fellbach

Phone: +49 711 5766-0

Fax: +49 711 575725

E-mail: [amf@amf.de](mailto:amf@amf.de)

Web: [www.amf.de](http://www.amf.de)

**Order no. 460592 · € 3,60**