

HOME OF CLAMPING



CATALOGUE 2026



2026
TOGGLE CLAMPS,
MANUAL AND PNEUMATIC

WE GENERATE EXCITEMENT.

Since the foundation of the company in 1890 until today the goal has remained the same: the highest quality in products and services. Nevertheless, the circumstances, tasks and challenges have changed, of course. By focussing on our core areas of expertise, we have long set new standards for innovative clamping technology - driven by our own development, the greatest possible flexibility and passion for individual solutions.

All this is only possible with committed and contented employees. Respectful interaction with others, personal development and measures for the wellbeing of each individual are therefore values that matter to us.



Company Management:
Wolfgang Balle, Johannes Maier (CEO), Jürgen Förster

OUR COMPANY HISTORY

- 1890 Company founded as a lock manufacturer by Andreas Maier.
- 1920 Product range extended to include spanners.
- 1928 Production line assembly of FELLBACH LOCKS.
- 1951 Introduces clamping elements and diversifies into workpiece and tool clamping technology.
- 1965 Toggle clamps extend the AMF product range, AMF catalogues are now printed in ten languages.
- 1975 Further specialisation into hydraulic clamping technology.
- 1982 Clamping and fixture systems round off AMF's clamping expertise.
- 1996 AMF team organisation in all sectors of the business, Quality management with certification to ISO 9001.
- 2001 AMF Service Guarantee for all products.
- 2004 Introduction of the ZPS zero-point clamping system.
- 2007 The magnetic clamping technology extends the AMF product range.
- 2009 Development and marketing of AMF Vacuum clamping technology.
- 2012 LOW-COST AUTOMATION gripping, clamping, marking and cleaning.
- 2014 AMF presents the most extensive product range of automation solution in zero-point clamping technology.
- 2017 Wireless sensing systems extend the expertise into Industry 4.0 and blends seamlessly into the AMF product range.

PLEDGES THAT COUNT IN EVERYDAY LIFE

For this reason, we have a few principles that we follow by conviction and which always apply.

INDIVIDUAL DEVELOPMENT

Even if the product you need does not even exist yet, we will find the right solution with you: from special designs to new developments, everything is possible.

WARRANTY

If, despite our high quality standard, there is a complaint, this is dealt with quickly and unbureaucratically, even beyond the warranty period.

HIGHEST QUALITY STANDARDS

Careful manufacturing based on tradition since 1890, and naturally with a modern quality management system according to ISO 9001 for many years.

SHORT DELIVERY TIME

With over 5,000 articles in our warehouse, you can expect your order to be dispatched on the same day.

COMPETENT SERVICE FROM EXPERTS

Your local retail partner or the specialists in our team will find the right solution for every task.

MADE IN GERMANY

Our entire product range is developed and manufactured exclusively by our employees in Germany.

VERTICAL TOGGLE CLAMPS		12 - 31
HORIZONTAL TOGGLE CLAMPS		32 - 43
PUSH-PULL TYPE TOGGLE CLAMPS		44 - 57
HOOK TYPE TOGGLE CLAMPS		58 - 65
TOGGLE CLAMPS WITH SAFETY LATCH		66 - 83
STAINLESS STEEL TOGGLE CLAMPS		84 - 103
AUTO-ADJUST TOGGLE CLAMPS		104 - 110
ESD TOGGLE CLAMPS		111 - 116
BLACK TOGGLE CLAMPS FOR OPTICAL MEASUREMENT TECHNOLOGY		117 - 130
PNEUMATIC TOGGLE CLAMPS, AUTOMATION CLAMPS PNEUMATIC SWING CLAMPS		131 - 153 154 - 161
ACCESSORIES		162 - 179



ESD TOGGLE CLAMPS
from page 111



PNEUMATIC TOGGLE CLAMP
6828M, page 148



LINK CLAMP, PNEUMATIC, FLANGE VERSION
6829LA, page 147



HEAVY PNEUMATIC TOGGLE CLAMP
6828U, page 152



VERTICALE TOGGLE CLAMP COMFORTLINE
6800C, page 15



HORIZONTAL TOGGLE CLAMP WITH OPEN-HOLDER, BLACK
6835BO, page 129

**AVAILABLE IN 6
DIFFERENT COLOURS!**



> ADVANTAGES OF „TOGGLE“ PRINCIPLE

- > Large and quick opening.
- > Clearing the workpieces completely for unimpeded handling of work.
- > Large power transmission. Minimum operating effort giving maximum clamping force.
- > The clamps are self-arresting, they remain locked, resisting the force produced when machining components.

> APPLICATIONS

A wide range of uses can be found for these AMF toggle clamps owing to their favourable power to movement ratio, and their easy action. These versatile clamps can be used in the metal working industry when drilling, welding, bending, grinding, testing and fitting, as well as in the wood and plastic industry in glueing, drilling, cutting and milling jigs.

> QUALITY FEATURES

To rationalize effectively, a design should be selected which will function for many years. AMF toggle clamps are equipped with ample dimensioned rivets which are moving in case-hardened bushes (with exception of size 0 and 1 for space reasons). All parts are galvanized prior to assembly. The tempered and galvanized clamping screw (strength class 8.8) is quickly adjustable by the T-slot nut or the special nut. Certain toggle clamps are also available in STAINLESS STEEL versions. Please see pages 84 to 103.

AMF toggle clamps are designed for ambient temperatures from -10°C to +80°C and are free of paint-wetting impairment substances.

> DESIGN AND SERVICE LIFE

Due to the different applications the design is of importance. Besides our high quality standard types extra heavy duty toggle clamps no. 6811P and no. 6812P are available.

> FORCES WITH HAND- AND PNEUMATIC TOGGLE CLAMPS

The selection of the correct toggle clamp size depends on the required clamping forces (refer to specification tables). The forces are shown in kN and one should distinguish between:

- Holding force F1 or F2
- Clamping force F3 or F4
- Piston force F5 (6 bar air pressure)

> THE CLAMPING FORCE

is the force applied when closing the clamp, measured between the arms and the component. As opposed to the pneumatic toggle clamps the clamping forces of manual clamps can not be correctly formulated as it is dependent on the operator.

> THE HOLDING FORCE

is the force the closed arm transmits to the workpiece, without itself being deformed when machine forces apply. When maximum force is reached, the hinged point goes over the dead centre, thereby insuring, that the action is locked and cannot be released until such time as the handle is returned to its original position.

> MOUNTING POSSIBILITIES

The base are offered in three versions: toggle clamps with horizontal base, vertical base (preferably used on welded construction and on webs) and toggle clamps with angle base for front mounting. With all toggle clamps the clamping screws are included in the price. Large quantities can be supplied without clamping screw if required.

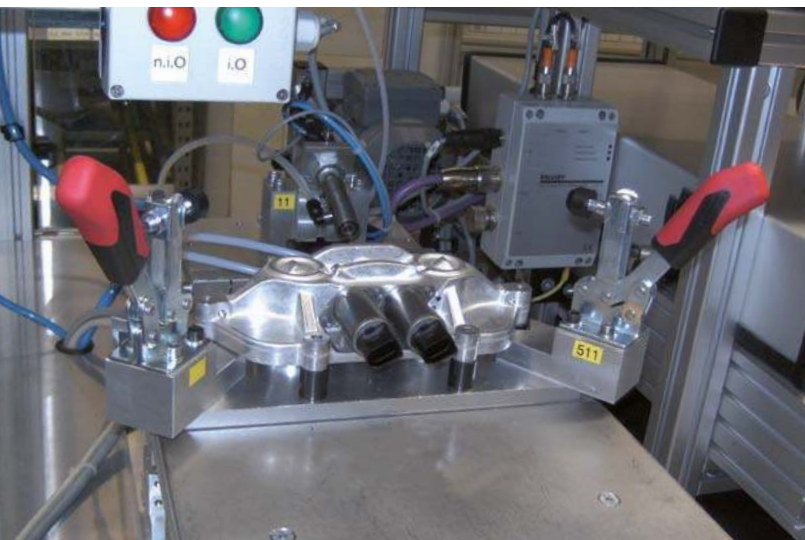

THE FEATURES OF OUR TOGGLE CLAMPS AT A GLANCE

- > Ergonomic two-component handle
- > Safety clamping piece with finger protection
- > Retainer for clamping screws.
- > Stainless steel rivets
- > Removable rubber cap

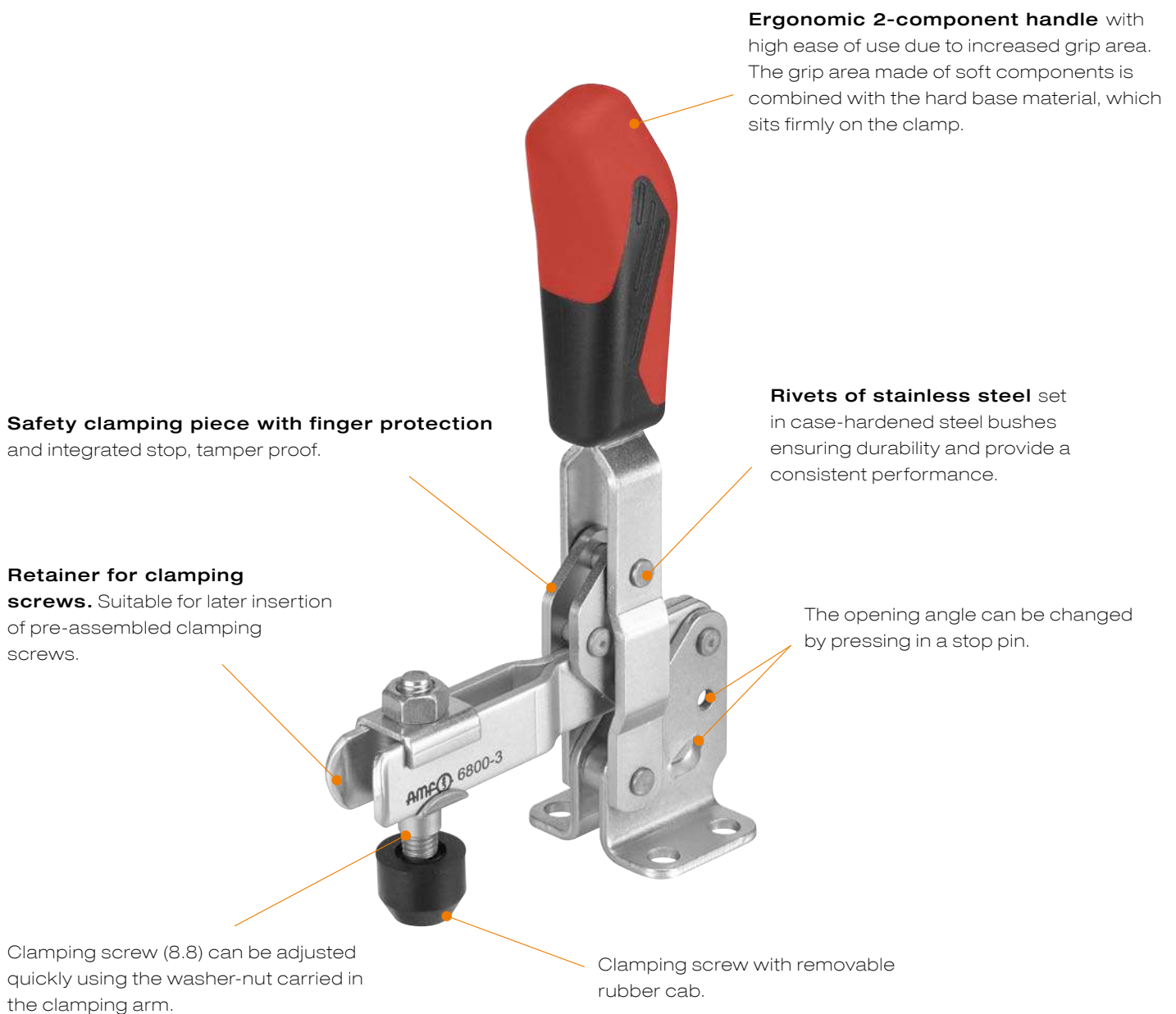

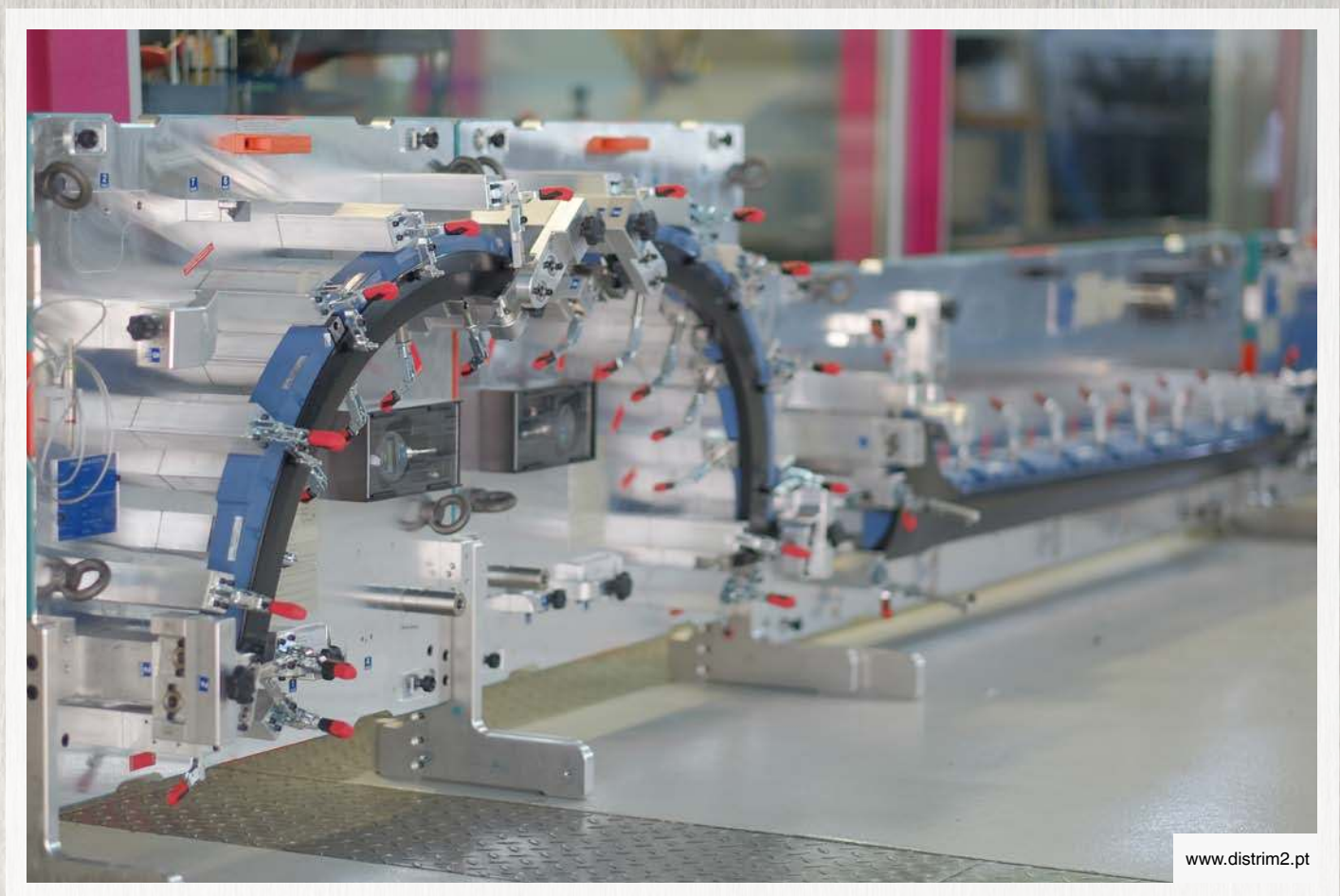
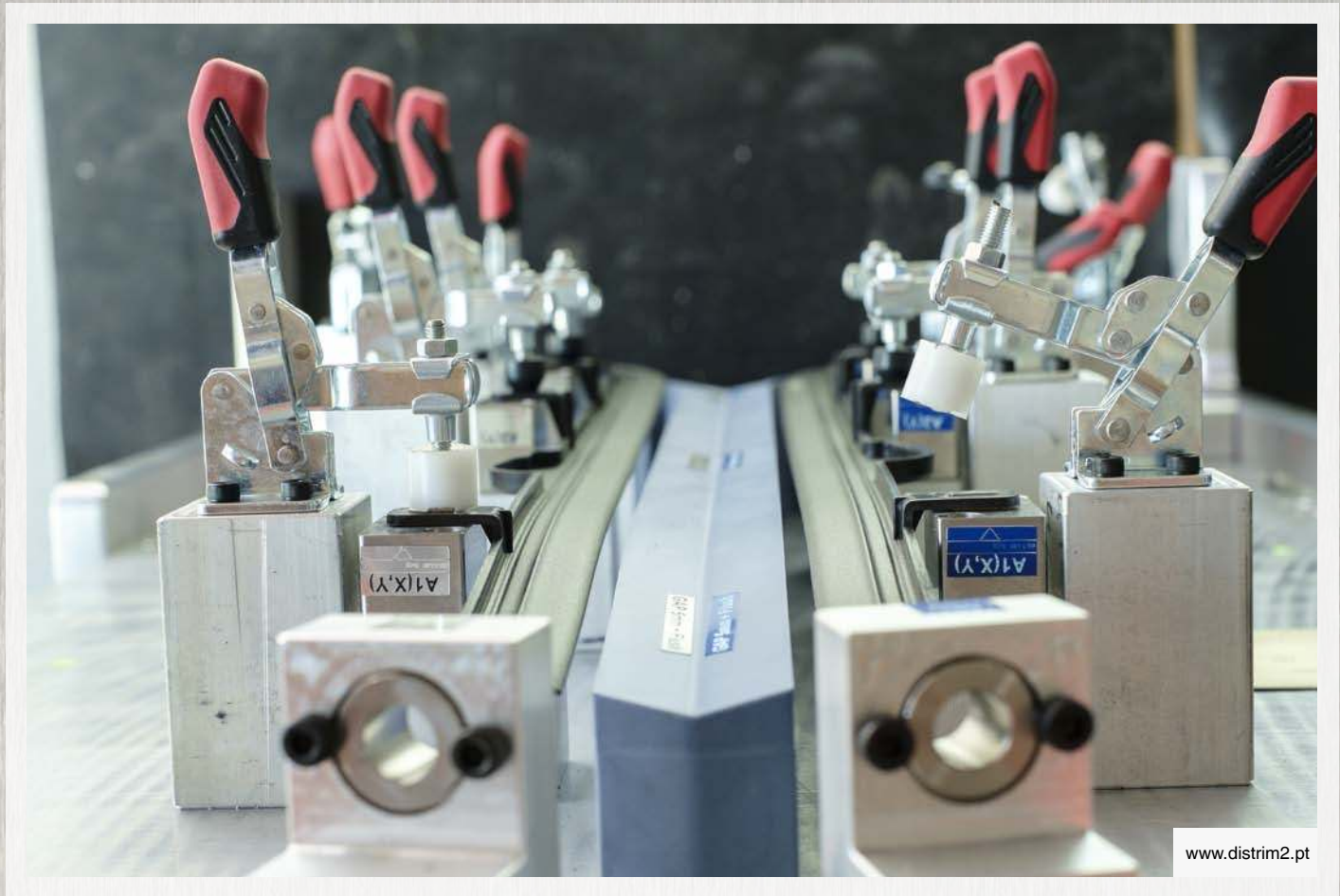

Subject to technical alterations.



Subject to technical alterations.

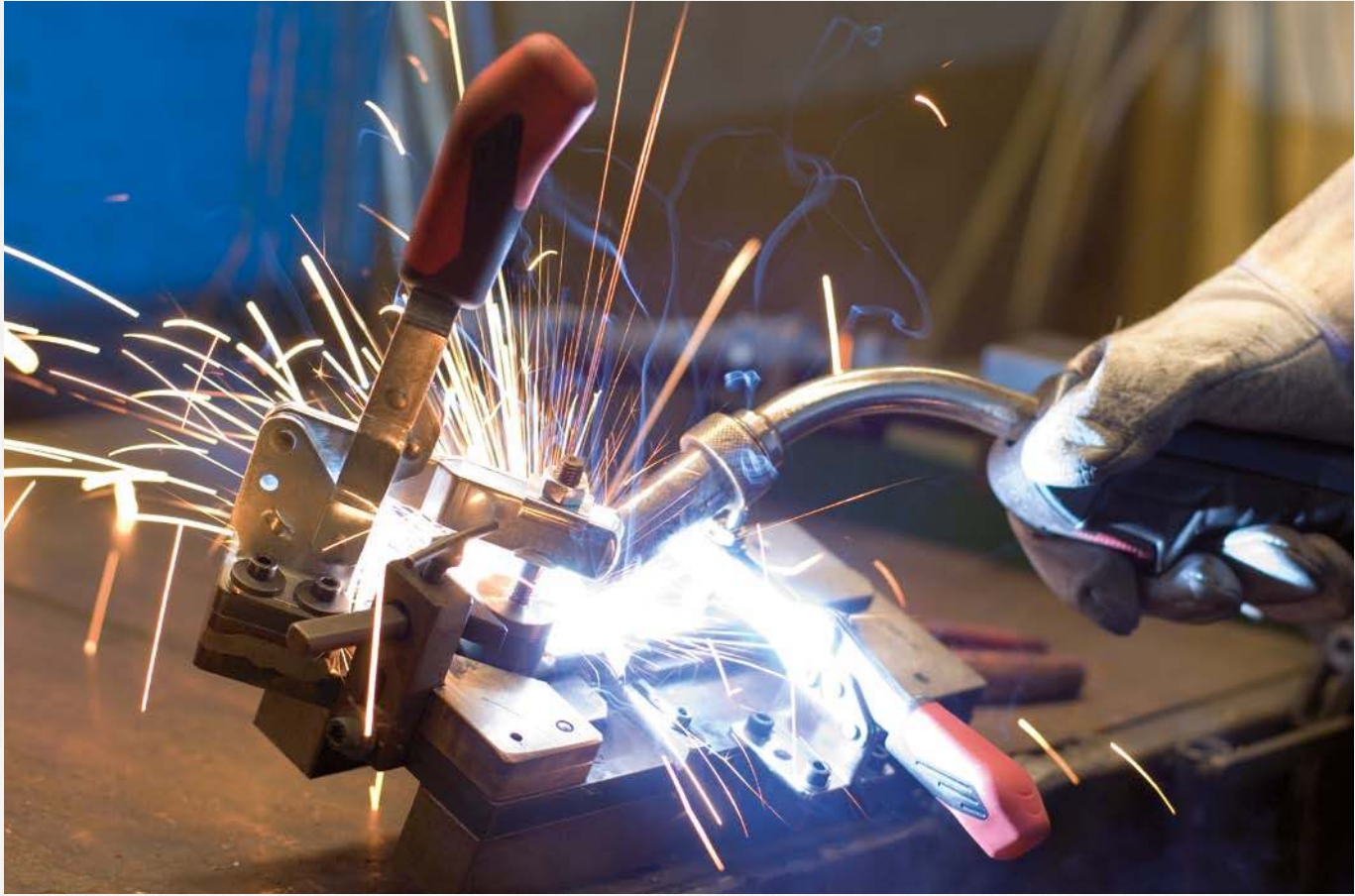

Subject to technical alterations.

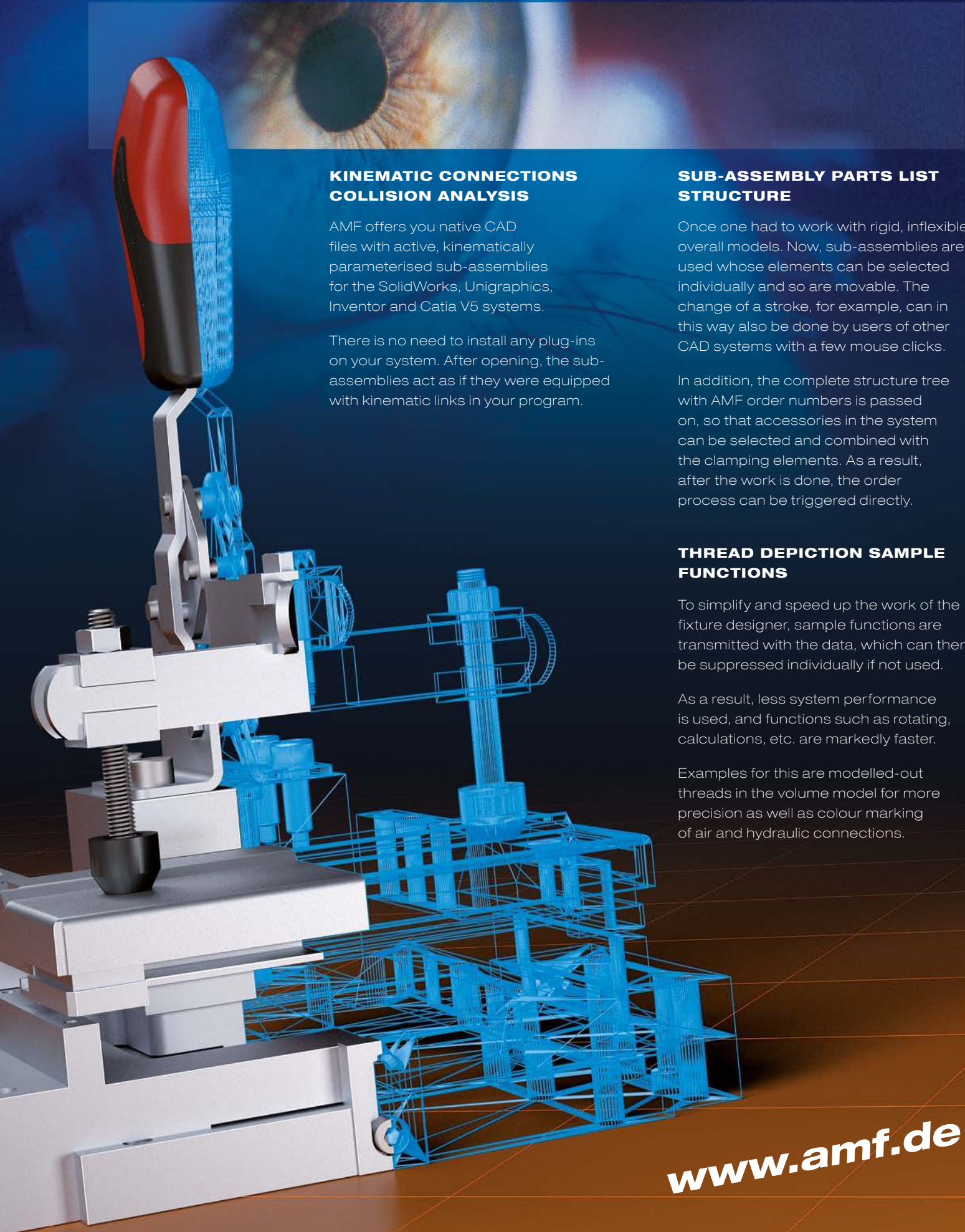

KINEMATIC CONNECTIONS COLLISION ANALYSIS

AMF offers you native CAD files with active, kinematically parameterised sub-assemblies for the SolidWorks, Unigraphics, Inventor and Catia V5 systems.

There is no need to install any plug-ins on your system. After opening, the sub-assemblies act as if they were equipped with kinematic links in your program.

SUB-ASSEMBLY PARTS LIST STRUCTURE

Once one had to work with rigid, inflexible overall models. Now, sub-assemblies are used whose elements can be selected individually and so are movable. The change of a stroke, for example, can in this way also be done by users of other CAD systems with a few mouse clicks.

In addition, the complete structure tree with AMF order numbers is passed on, so that accessories in the system can be selected and combined with the clamping elements. As a result, after the work is done, the order process can be triggered directly.

THREAD DEPICTION SAMPLE FUNCTIONS

To simplify and speed up the work of the fixture designer, sample functions are transmitted with the data, which can then be suppressed individually if not used.

As a result, less system performance is used, and functions such as rotating, calculations, etc. are markedly faster.

Examples for this are modelled-out threads in the volume model for more precision as well as colour marking of air and hydraulic connections.

No. 6800

Vertical toggle clamp with red handle

with open clamping arm and horizontal base.

Galvanized and passivated. Rivets made of stainless steel, which, for sizes 2 to 6, run in hardened bushings. Bearings are pre-lubricated.

Ergonomic, oil-resistant handle with large grip surface and soft components. Safety clamping piece with finger protection, lock washer for the thrust bolt at the end of the clamping arm.

Complete with tempered, galvanized clamping screw no. 6890.



Order no.	Size	F1 [kN]	F2 [kN]	Clamping screw	Weight [g]
90001	0	0,5	0,7	M 4x 25	60
90019	1	0,6	1,1	M 5x 30	105
90027	2	0,8	1,2	M 6x 35	175
90035	3	1,2	2,5	M 8x 45	410
90043	4	1,7	3,0	M 8x 65	630
90050	5	3,0	5,0	M12x 80	1480
90068	6	3,4	5,5	M12x110	2200

Also available in „STAINLESS STEEL“ version (no. 6800NI) and in matte-black version (no. 6800B)!

No. 6800Y

Vertical toggle clamp with yellow handle



Order no.	Size	F1 [kN]	F2 [kN]	Clamping screw	Weight [g]
557009	0	0,5	0,7	M 4x 25	60
557010	1	0,6	1,1	M 5x 30	105
557011	2	0,8	1,2	M 6x 35	175
557012	3	1,2	2,5	M 8x 45	410
557013	4	1,7	3,0	M 8x 65	630
557014	5	3,0	5,0	M12x 80	1480
557015	6	3,4	5,5	M12x110	2200

Also available in „STAINLESS STEEL“ version (no. 6800NIY).

No. 6800J

Vertical toggle clamp with orange handle



Order no.	Size	F1 [kN]	F2 [kN]	Clamping screw	Weight [g]
557301	0	0,5	0,7	M 4x 25	60
557302	1	0,6	1,1	M 5x 30	105
557303	2	0,8	1,2	M 6x 35	175
557304	3	1,2	2,5	M 8x 45	410
557305	4	1,7	3,0	M 8x 65	630
557306	5	3,0	5,0	M12x 80	1480
557307	6	3,4	5,5	M12x110	2200

Also available in „STAINLESS STEEL“ version (no. 6800NIJ).

No. 6800E

Vertical toggle clamp with blue handle



Order no.	Size	F1 [kN]	F2 [kN]	Clamping screw	Weight [g]
557615	0	0,5	0,7	M 4x 25	60
557616	1	0,6	1,1	M 5x 30	105
557617	2	0,8	1,2	M 6x 35	175
557618	3	1,2	2,5	M 8x 45	410
557619	4	1,7	3,0	M 8x 65	630
557620	5	3,0	5,0	M12x 80	1480
557621	6	3,4	5,5	M12x110	2200

Also available in „STAINLESS STEEL“ version (no. 6800NIE).

Subject to technical alterations.

No. 6800G

Vertical toggle clamp with green handle



Order no.	Size	F1 [kN]	F2 [kN]	Clamping screw	Weight [g]
557465	0	0,5	0,7	M 4x 25	60
557466	1	0,6	1,1	M 5x 30	105
557467	2	0,8	1,2	M 6x 35	175
557468	3	1,2	2,5	M 8x 45	410
557469	4	1,7	3,0	M 8x 65	630
557470	5	3,0	5,0	M12x 80	1480
557471	6	3,4	5,5	M12x110	2200

Also available in „STAINLESS STEEL“ version (no. 6800NIG).

No. 6800T

Vertical toggle clamp with black handle



Order no.	Size	F1 [kN]	F2 [kN]	Clamping screw	Weight [g]
557963	0	0,5	0,7	M 4x 25	60
557964	1	0,6	1,1	M 5x 30	105
557965	2	0,8	1,2	M 6x 35	175
557966	3	1,2	2,5	M 8x 45	410
557967	4	1,7	3,0	M 8x 65	630
557968	5	3,0	5,0	M12x 80	1480
557969	6	3,4	5,5	M12x110	2200

Also available in „STAINLESS STEEL“ version (no. 6800NIT).

Recommendations



No. 6895,
page 178



No. 6892,
page 170



No. 6800S,
page 66

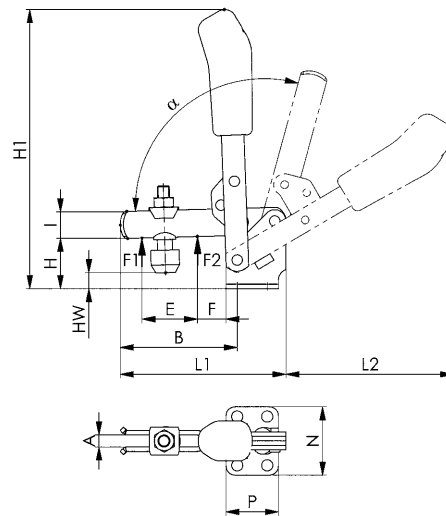

CAD

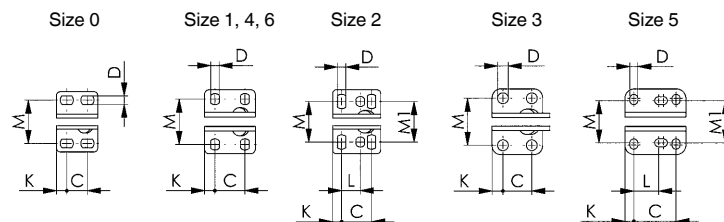

Dimensions:

Size	A	B	C	D	E	F	H	H1	HW min.	HW max.	I	K	L	L1	L2	M	M1	N	P	α	α^*
0	4	31,0	8,5-13,5	4,5	14	5,5	18,0	81,0	-1,5	3,5	8	5,5	-	49	50	23,0	-	32	22	95°	-
1	5	39,0	16,0	4,5	18	6,0	19,0	98,0	-4,0	2,0	10	5,5	-	61	58	22,5-26,0	-	34	27	95°	-
2	6	52,0	20,0	5,5	25	11,0	23,0	140,0	-3,0	4,5	12	6,0	12,5	78	89	23,0-31,0	27	43	32	105°	60°
3	8	79,0	20,0	7,5	37	19,0	33,0	186,0	2,0	11,0	18	7,5	-	112	112	32,5	-	46	35	105°	60°
4	10	101,0	32,0	8,6	54	16,0	42,5	221,0	-6,0	22,5	20	13,0	-	141	130	43,0-46,5	-	64	53	105°	60°
5	14	140,0	45,0	8,5	73	34,0	55,8	281,0	-3,0	27,5	25	9,5	26,5-31,5	195	185	45,0-50,0	45	70	65	115°	60°
6	14	165,5	50,5	13,0	89	28,0	81,0	333,0	-2,5	55,0	30	24,5	-	231	206	67,5-72,5	-	100	90	140°	60°

* The opening angle can be changed by pressing in a stop pin.

Subject to technical alterations.

TOGGLE CLAMP COMFORTLINE

The advantages at a glance:

- > Ergonomic hand positioning without bending of joints and nerve paths
- > Force distribution over the entire hand surface through ergonomic grip size
- > Low hand force required
- > Higher productivity from healthy and motivated employees
- > Cost savings through less loss of work hours
- > Replaceable with 6800 in the same size
- > Clamping screw does not need to be shortened
- > Workpiece can be removed vertically

The comfortline toggle clamp from AMF was developed especially for ergonomic work.

In industrial workplaces, activities with many repetitive movements and high force levels as well as work requiring extreme joint and body positions create a risk of musculoskeletal disorders.

Working with the Human Movement and Training Science Department of the University of Hamburg as well as with professional users, we have developed a toggle clamp that prevents exactly these physical loads. The ergonomic product design of the toggle clamps lets the user maintain a natural wrist positioning and movement, which results in constant blood flow and relief of muscle strain. In addition, the straight-line design of the clamp prevents excessive strain and pain in shoulders and wrists.

The required hand force is markedly reduced through the changed kinematics. This ensures an ideal force flow and reduces the risk of injury for users. The relief of strain on joints and muscles allows a relaxed and fatigue-free positioning of the hand and increases work comfort and safety.

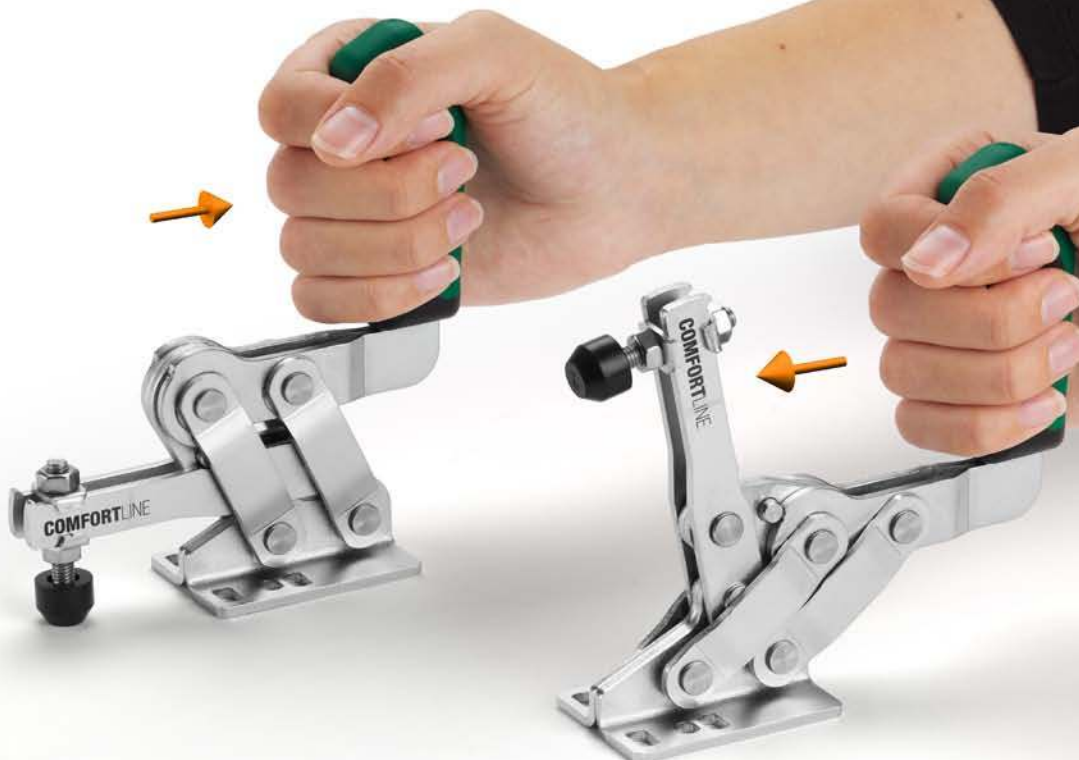

Subject to technical alterations.

No. 6800C

Vertical toggle clamp comfortline

Ergonomically optimised vertical toggle clamp for increased work economics.

Improved protection of muscles and joints thanks to a natural wrist position and movement. Oil-resistant 2-component grip with soft components and ergonomic grip size.

With open clamping arm and horizontal foot. Galvanised and passivated. Stainless steel rivets which, for sizes 2 to 3, run in hardened bearing bushes. Bearing positions are greased. Safety clamping piece with finger protection, retainer for the clamping screw at the end of the clamping arm.

Complete with tempered galvanised clamping screw no. 6890C.

Order no.	Size	F1 [kN]	F2 [kN]	Clamping screw	Weight [g]
564132	1	0,6	1,1	M5 x 30	409
564133	2	0,8	1,2	M6 x 35	486
564134	3	1,2	2,5	M8 x 45	784

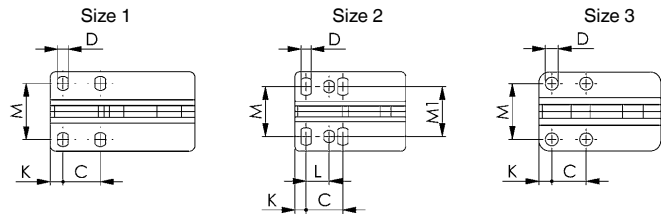
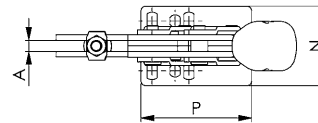
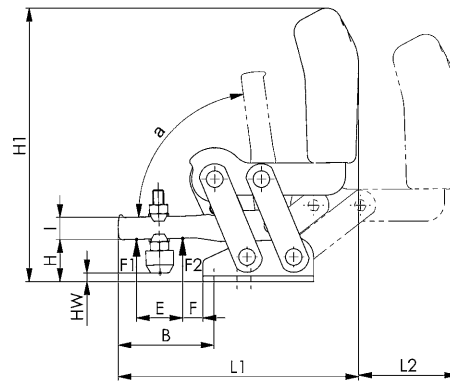

Recommendations



No. 6800,
page 12



No. 6890C,
page 164

Dimensions:

Order no.	Size	A	B	C	D	E	F	H	H1	HW min.	HW max.	I	K	L	L1	L2	M	M1	N	P	α
564132	1	5	38,5	16	4,5	17	7	18,5	142	-4,5	3,7	10	5,5	-	108,0	56	24,0 - 25,5	-	34	62	59°
564133	2	6	52,0	20	5,5	25	11	22,8	148	-3,0	5,0	12	6,0	12,5	129,0	56	27,0 - 31,0	27	43	60	55°
564134	3	8	78,8	20	7,5	37	19	33,3	168	2,4	11,0	18	7,5	-	155,5	66	32,5	-	46	71	60°

No. 6802

Vertical toggle clamp with red handle

with open clamping arm and vertical base.

Galvanized and passivated. Rivets made of stainless steel, which, for sizes 2 to 6, run in hardened bushings. Bearings are pre-lubricated.

Ergonomic, oil-resistant handle with large grip surface and soft components. Safety clamping piece with finger protection. Lock washer for the thrust bolt at the end of the clamping arm.

Complete with tempered, galvanized clamping screw no. 6890.



Order no.	Size	F1 [kN]	F2 [kN]	Clamping screw	Weight [g]
90217	1	0,6	1,1	M 5x 30	105
90225	2	0,8	1,2	M 6x 35	175
90233	3	1,2	2,5	M 8x 45	410
90241	4	1,7	3,0	M 8x 65	630
90258	5	3,0	5,0	M12x 80	1480
90266	6	3,4	5,5	M12x110	2200

Also available in matte-black version (no. 6802B)!

No. 6802Y

Vertical toggle clamp with yellow handle



Order no.	Size	F1 [kN]	F2 [kN]	Clamping screw	Weight [g]
557018	1	0,6	1,1	M 5x 30	105
557019	2	0,8	1,2	M 6x 35	175
557020	3	1,2	2,5	M 8x 45	410
557021	4	1,7	3,0	M 8x 65	630
557022	5	3,0	5,0	M12x 80	1480
557023	6	3,4	5,5	M12x110	2200

No. 6802J

Vertical toggle clamp with orange handle



Order no.	Size	F1 [kN]	F2 [kN]	Clamping screw	Weight [g]
557310	1	0,6	1,1	M 5x 30	105
557311	2	0,8	1,2	M 6x 35	175
557312	3	1,2	2,5	M 8x 45	410
557313	4	1,7	3,0	M 8x 65	630
557314	5	3,0	5,0	M12x 80	1480
557315	6	3,4	5,5	M12x110	2200

No. 6802E

Vertical toggle clamp with blue handle



Order no.	Size	F1 [kN]	F2 [kN]	Clamping screw	Weight [g]
557622	1	0,6	1,1	M 5x 30	105
557623	2	0,8	1,2	M 6x 35	175
557624	3	1,2	2,5	M 8x 45	410
557625	4	1,7	3,0	M 8x 65	630
557626	5	3,0	5,0	M12x 80	1480
557627	6	3,4	5,5	M12x110	2200

Subject to technical alterations.

No. 6802G

Vertical toggle clamp with green handle



Order no.	Size	F1 [kN]	F2 [kN]	Clamping screw	Weight [g]
557472	1	0,6	1,1	M 5x 30	105
557473	2	0,8	1,2	M 6x 35	175
557474	3	1,2	2,5	M 8x 45	410
557475	4	1,7	3,0	M 8x 65	630
557476	5	3,0	5,0	M12x 80	1480
557477	6	3,4	5,5	M12x110	2200

No. 6802T

Vertical toggle clamp with black handle



Order no.	Size	F1 [kN]	F2 [kN]	Clamping screw	Weight [g]
557970	1	0,6	1,1	M 5x 30	105
557971	2	0,8	1,2	M 6x 35	175
557972	3	1,2	2,5	M 8x 45	410
557973	4	1,7	3,0	M 8x 65	630
557974	5	3,0	5,0	M12x 80	1480
557975	6	3,4	5,5	M12x110	2200



CAD

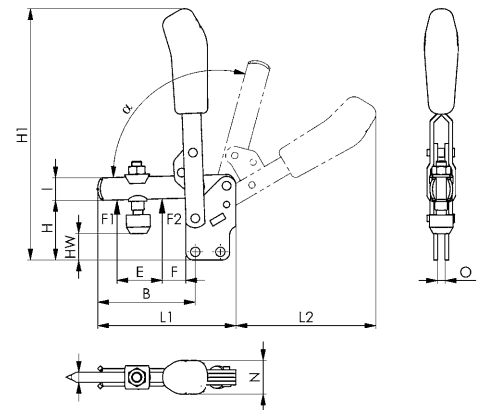

Size 1

Size 2

Size 3, 4

Size 5

Size 6

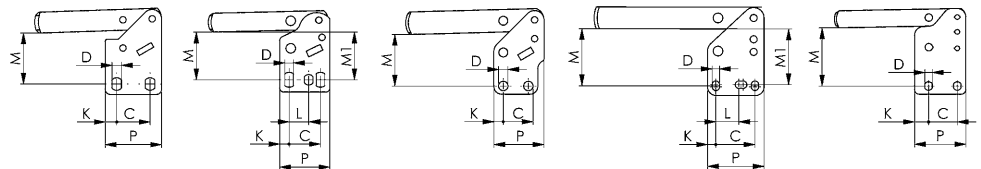

Recommendations



No. 6891, page 168



No. 6802S, page 68

Dimensions:

Size	A	B	C	D	E	F	H	H1	HW min.	HW max.	I	K	L	L1	L2	M	M1	N	O	P	α	α*
1	5	39,0	16,0	4,5	18	6	29	109	6,0	12,5	10	5,5	-	61	59	23,5-25,0	-	19	5	27	95°	-
2	6	52,0	20,0	5,5	25	11	38	154	11,5	19,5	12	6,0	12,5	78	80	28,5-32,5	30-31	21	5	32	105°	60°
3	8	79,0	20,0	7,5	36	19	48	200	16,5	25,0	18	7,5	-	112	114	41,0	-	27	6	40	105°	60°
4	10	101,0	32,0	8,6	54	16	65	244	16,5	45,5	20	13,0	-	141	130	55,5	-	35	8	53	105°	60°
5	14	140,0	45,0	8,5	72	35	77	301	18,0	49,0	25	9,5	26,5-31,5	195	183	64,5-67,0	64,0	45	10	65	115°	60°
6	14	165,5	50,5	13,0	89	28	117	369	33,0	90,5	30	24,5	-	231	206	101,0-103,5	-	45	10	90	140°	60°

* The opening angle can be changed by pressing in a stop pin.

Subject to technical alterations.

No. 6803

Vertical toggle clamp with red handle

with open clamping arm and angle base.

Galvanized and passivated. Rivets made of stainless steel, which, for sizes 2 and 3, run in hardened bushings. Bearings are pre-lubricated.

Ergonomic, oil-resistant handle with large grip surface and soft components. Safety clamping piece with finger protection. Lock washer for the thrust bolt at the end of the clamping arm.

Complete with tempered, galvanized clamping screw no. 6890.



Order no.	Size	F1 [kN]	F2 [kN]	Clamping screw	Weight [g]
90316	1	0,6	1,1	M5x30	125
90324	2	0,8	1,2	M6x35	220
90332	3	1,2	2,5	M8x45	400
90340	4	1,7	3,0	M8x65	650

Also available in „STAINLESS STEEL“ version (no. 6803NI).

No. 6803Y

Vertical toggle clamp with yellow handle



Order no.	Size	F1 [kN]	F2 [kN]	Clamping screw	Weight [g]
557024	1	0,6	1,1	M5x30	125
557025	2	0,8	1,2	M6x35	220
557026	3	1,2	2,5	M8x45	400
557027	4	1,7	3,0	M8x65	650

Also available in „STAINLESS STEEL“ version (no. 6803NIY).

No. 6803J

Vertical toggle clamp with orange handle



Order no.	Size	F1 [kN]	F2 [kN]	Clamping screw	Weight [g]
557318	1	0,6	1,1	M5x30	125
557319	2	0,8	1,2	M6x35	220
557320	3	1,2	2,5	M8x45	400
557321	4	1,7	3,0	M8x65	650

Also available in „STAINLESS STEEL“ version (no. 6803NIJ).

No. 6803E

Vertical toggle clamp with blue handle



Order no.	Size	F1 [kN]	F2 [kN]	Clamping screw	Weight [g]
557630	1	0,6	1,1	M5x30	125
557631	2	0,8	1,2	M6x35	220
557632	3	1,2	2,5	M8x45	400
557633	4	1,7	3,0	M8x65	650

Also available in „STAINLESS STEEL“ version (no. 6803NIE).

Subject to technical alterations.

No. 6803G

Vertical toggle clamp with green handle



Order no.	Size	F1 [kN]	F2 [kN]	Clamping screw	Weight [g]
557479	1	0,6	1,1	M5x30	125
557480	2	0,8	1,2	M6x35	220
557481	3	1,2	2,5	M8x45	400
557482	4	1,7	3,0	M8x65	650

Also available in „STAINLESS STEEL“ version (no. 6803NIG).

No. 6803T

Vertical toggle clamp with black handle



Order no.	Size	F1 [kN]	F2 [kN]	Clamping screw	Weight [g]
557977	1	0,6	1,1	M5x30	125
557978	2	0,8	1,2	M6x35	220
557979	3	1,2	2,5	M8x45	400
557980	4	1,7	3,0	M8x65	650

Also available in „STAINLESS STEEL“ version (no. 6803NIT).

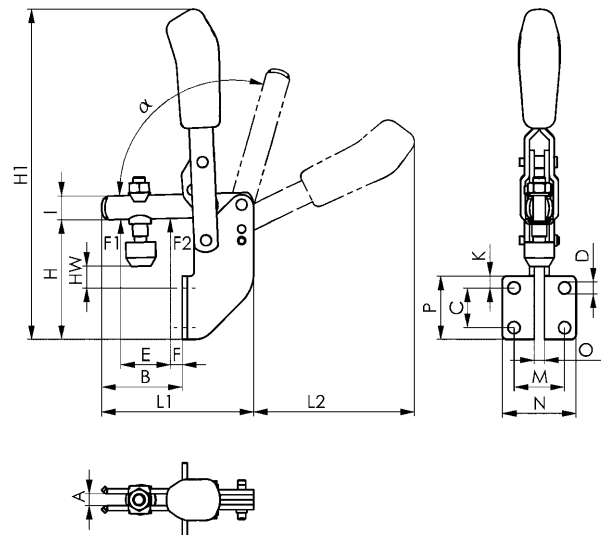

CAD

Recommendations



No. 6895,
page 178



No. 6896,
page 171



No. 6803S,
page 70

Dimensions:

Size	A	B	C	D	E	F	H	H1	HW min.	HW max.	I	K	L1	L2	M	N	O	P	α	α^*
1	5	34,5	14	4,5	18	7	45,0	125,0	2,5	9,0	10	10	61	58	20,0	30,0	5	30	98°	-
2	6	41,0	20	6,1	25	6	60,0	176,5	8,0	15,5	12	6	77	90	25,5	37,0	5	32	105°	60°
3	8	62,0	24	6,5	37	11	71,0	223,0	9,0	17,5	18	7	110	112	28,5	42,5	6	38	105°	60°
4	10	83,0	32	8,5	54	11	101,5	280,0	11,0	39,5	20	54	141	129	32,0	52,0	8	96	105°	60°

* The opening angle can be changed by pressing in a stop pin.

Subject to technical alterations.

No. 6804

Vertical toggle clamp with red handle with solid arm and horizontal base.

Galvanized and passivated.

Stainless steel rivets, which run in hardened bushes. Bearings are pre-lubricated.

Ergonomic, oil-resistant handle with large grip surface and soft components. Safety clamping piece with finger protection.

Complete with tempered, galvanized clamping screw no. 6885 and sleeve to weld on.



Order no.	Size	F1 [kN]	F2 [kN]	Clamping screw	Weight [g]
90431	3	1,4	2,5	M8x45	340
90449	4	2,0	3,0	M8x65	585
90456	5	3,0	5,0	M12x80	1480
90464	6	3,5	5,5	M12x110	2200

No. 6804Y

Vertical toggle clamp with yellow handle



Order no.	Size	F1 [kN]	F2 [kN]	Clamping screw	Weight [g]
557028	3	1,4	2,5	M8x45	340
557029	4	2,0	3,0	M8x65	585
557030	5	3,0	5,0	M12x80	1480
557031	6	3,5	5,5	M12x110	2200

No. 6804J

Vertical toggle clamp with orange handle



Order no.	Size	F1 [kN]	F2 [kN]	Clamping screw	Weight [g]
557322	3	1,4	2,5	M8x45	340
557323	4	2,0	3,0	M8x65	585
557324	5	3,0	5,0	M12x80	1480
557325	6	3,5	5,5	M12x110	2200

No. 6804E

Vertical toggle clamp with blue handle



Order no.	Size	F1 [kN]	F2 [kN]	Clamping screw	Weight [g]
557635	3	1,4	2,5	M8x45	340
557636	4	2,0	3,0	M8x65	585
557637	5	3,0	5,0	M12x80	1480
557638	6	3,5	5,5	M12x110	2200

Subject to technical alterations.

No. 6804G

Vertical toggle clamp with green handle



Order no.	Size	F1 [kN]	F2 [kN]	Clamping screw	Weight [g]
557483	3	1,4	2,5	M8x45	340
557484	4	2,0	3,0	M8x65	585
557485	5	3,0	5,0	M12x80	1480
557486	6	3,5	5,5	M12x110	2200

No. 6804T

Vertical toggle clamp with black handle



Order no.	Size	F1 [kN]	F2 [kN]	Clamping screw	Weight [g]
557981	3	1,4	2,5	M8x45	340
557982	4	2,0	3,0	M8x65	585
557983	5	3,0	5,0	M12x80	1480
557984	6	3,5	5,5	M12x110	2200

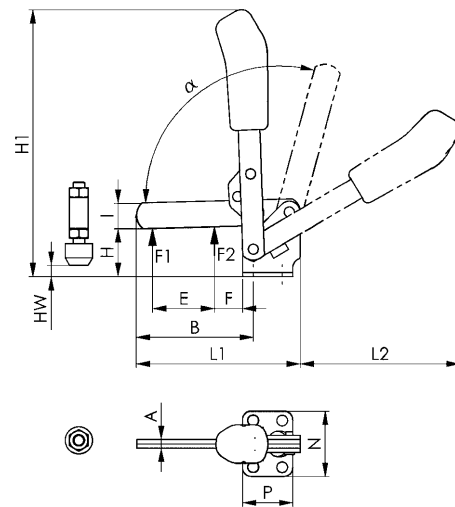

Recommendations



No. 6886,
page 168



No. 6805,
page 24



No. 6804S,
page 72

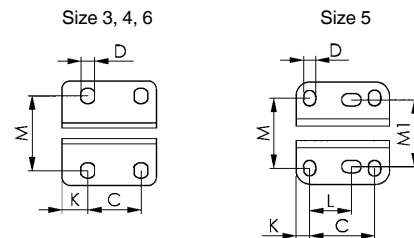

Dimensions:

Size	A	B	C	D	E	F	H	H1	HW min.	HW max.	I	K	L	L1	L2	M	M1	N	P	α	α^*
3	6	81,0	20,0	7,5	43	19,5	33,5	186	0	12,0	18	7,5	-	108,5	116,5	32,5	-	46	35	105°	60°
4	8	101,0	32,0	8,6	61	17,0	42,5	221	-8	21,0	20	13,0	-	141,5	129,5	45,0	-	64	53	105°	60°
5	10	141,0	45,0	8,5	88	30,5	55,5	281	-6	25,5	25	9,5	26,5-31,5	196,5	184,0	45-50	45	70	65	115°	60°
6	10	166,5	50,5	13,0	90	20,5	81,0	331	-5	51,0	30	24,5	-	232,0	206,0	68-72	-	100	90	140°	60°

* The opening angle can be changed by pressing in a stop pin.

Subject to technical alterations.

No. 6806

Vertical toggle clamp with red handle

with solid arm and vertical base.

Galvanized and passivated.

Stainless steel rivets, which run in hardened bushes. Bearings are pre-lubricated.

Ergonomic, oil-resistant handle with large grip surface and soft components. Safety clamping piece with finger protection.

Complete with tempered, galvanized clamping screw no. 6885 and sleeve to weld on.



Order no.	Size	F1 [kN]	F2 [kN]	Clamping screw	Weight [g]
90555	3	1,4	2,5	M 8x 45	400
90563	4	2,0	3,0	M 8x 65	585
90571	5	3,0	5,0	M12x 80	1480
90589	6	3,5	5,5	M12x110	2200

No. 6806Y

Vertical toggle clamp with yellow handle



Order no.	Size	F1 [kN]	F2 [kN]	Clamping screw	Weight [g]
557032	3	1,4	2,5	M 8x 45	400
557033	4	2,0	3,0	M 8x 65	585
557034	5	3,0	5,0	M12x 80	1480
557035	6	3,5	5,5	M12x110	2200

No. 6806J

Vertical toggle clamp with orange handle



Order no.	Size	F1 [kN]	F2 [kN]	Clamping screw	Weight [g]
557326	3	1,4	2,5	M 8x 45	400
557327	4	2,0	3,0	M 8x 65	585
557328	5	3,0	5,0	M12x 80	1480
557329	6	3,5	5,5	M12x110	2200

No. 6806E

Vertical toggle clamp with blue handle



Order no.	Size	F1 [kN]	F2 [kN]	Clamping screw	Weight [g]
557650	3	1,4	2,5	M 8x 45	400
557651	4	2,0	3,0	M 8x 65	585
557652	5	3,0	5,0	M12x 80	1480
557653	6	3,5	5,5	M12x110	2200

Subject to technical alterations.

No. 6806G

Vertical toggle clamp with green handle



Order no.	Size	F1 [kN]	F2 [kN]	Clamping screw	Weight [g]
557487	3	1,4	2,5	M 8x 45	400
557488	4	2,0	3,0	M 8x 65	585
557489	5	3,0	5,0	M12x 80	1480
557490	6	3,5	5,5	M12x110	2200

No. 6806T

Vertical toggle clamp with black handle



Order no.	Size	F1 [kN]	F2 [kN]	Clamping screw	Weight [g]
557985	3	1,4	2,5	M 8x 45	400
557986	4	2,0	3,0	M 8x 65	585
557987	5	3,0	5,0	M12x 80	1480
557988	6	3,5	5,5	M12x110	2200

Recommendations



No. 6886,
page 168



No. 6802,
page 16



No. 6804,
page 20

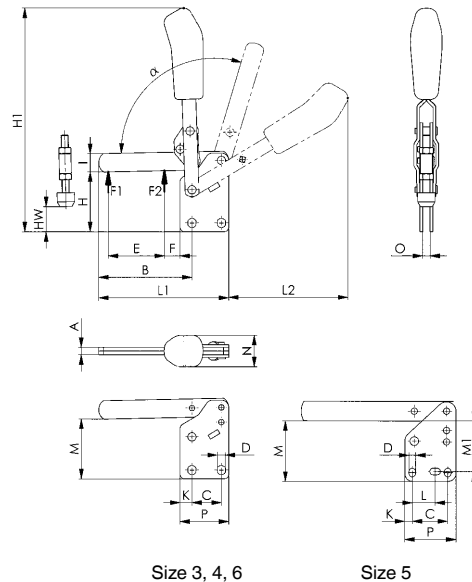

CAD

Size 3, 4, 6

Size 5

Dimensions:

Size	A	B	C	D	E	F	H	H1	HW min.	HW max.	I	K	L	L1	L2	M	M1	N	O	P	α	α*
3	6	81,0	20,0	7,5	43	19,5	48	200	14,5	26,0	18	7,5	-	108,5	111,0	41,0	-	27	6	35	105°	60°
4	8	101,0	32,0	8,6	61	17,0	65	244	13,0	44,0	20	13,0	-	141,5	129,5	55,5	-	34	8	53	105°	60°
5	10	141,0	45,0	8,5	88	30,5	77	302	15,0	47,0	25	9,5	26,5-31,5	196,5	184,0	66,0	64	36	10	65	115°	60°
6	10	166,5	50,5	13,0	90	20,5	117	369	28,5	86,5	30	24,5	-	232,0	206,0	102,0	-	39	10	90	140°	60°

* The opening angle can be changed by pressing in a stop pin.

Subject to technical alterations.

No. 6805

Vertical toggle clamp with red handle clamping arm with fixed distance of clamping screw and horizontal base.

Galvanized and passivated. Stainless steel rivets. Bearings are pre-lubricated.
Ergonomic, oil-resistant handle with large grip surface and soft components. Safety clamping piece with finger protection.
Complete with tempered, galvanized clamping screw no. 6885.



Order no.	Size	F1 [kN]	Clamping screw	Weight [g]
90514	1	1	M5x30	100

No. 6805Y

Vertical toggle clamp with yellow handle



Order no.	Size	F1 [kN]	Clamping screw	Weight [g]
557037	1	1	M5x30	100

No. 6805J

Vertical toggle clamp with orange handle



Order no.	Size	F1 [kN]	Clamping screw	Weight [g]
557330	1	1	M5x30	100

No. 6805E

Vertical toggle clamp with blue handle



Order no.	Size	F1 [kN]	Clamping screw	Weight [g]
557654	1	1	M5x30	100

Subject to technical alterations.

No. 6805G

Vertical toggle clamp with green handle



Order no.	Size	F1 [kN]	Clamping screw	Weight [g]
557491	1	1	M5x30	100

No. 6805T

Vertical toggle clamp with black handle



Order no.	Size	F1 [kN]	Clamping screw	Weight [g]
557989	1	1	M5x30	100

Recommendations



No. 6886,
page 168



No. 6804,
page 20

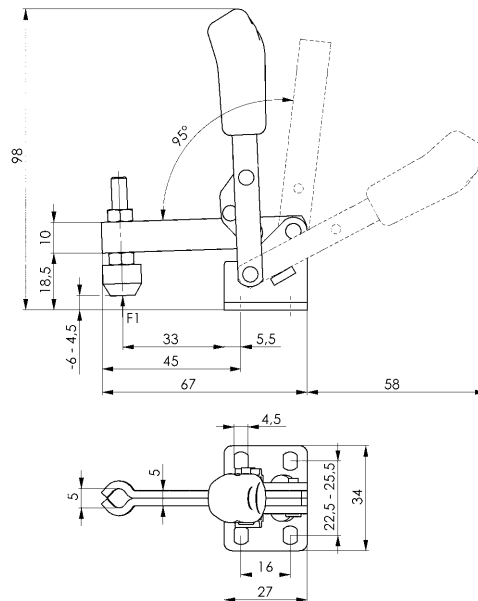

CAD

No. 6811P

Heavy vertical toggle clamp

with horizontal base.

Reamed and case-hardened bearing bushes.

Hardened, ground and permanently-lubricated pins. Clamp nuts

on lever arm to vary friction in movement. Material: steel, blued.

Lever arm made of cast steel, blued. Handle of red, oil-resistant

plastic.

Complete with tempered, galvanized clamping screw

no. 6885.



CAD

Order no.	Size	F1 [kN]	Clamping screw	Weight [g]
91314	2	2,5	M 6x 50	320
90878	4	5,0	M12x 80	1250
90886	6	6,0	M12x110	2130
90894	8	12,0	M12x110	4050

Note:

These heavy vertical toggle clamps are especially suitable for production equipment and fixtures.

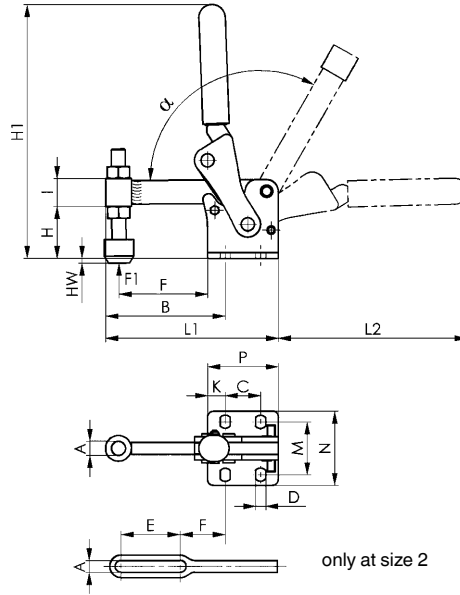

Recommendations



No. 6805,
page 24



No. 6812P,
page 27

Dimensions:

Order no.	Size	A	B	C	D	E	F	H	H1	HW min.	HW max.	I	K	L1	L2	M	N	P	α
91314	2	6,1	57	20	7,1	30	21	25	127	-13,5	6	15	8,5	85	94	32	47	37	120°
90878	4	12,2	100	30	8,5	-	75	44	216	-19,0	14	24	15,0	146	160	45	65	60	120°
90886	6	12,2	121	45	10,5	-	95	65	263	-22,0	35	30	15,0	181	185	52	78	75	120°
90894	8	12,2	151	55	12,5	-	120	71	303	-10,0	41	36	20,0	226	203	75	108	95	120°



Subject to technical alterations.

No. 6812P

Heavy vertical toggle clamp

with vertical base and mounting holes.

Reamed and case-hardened bearing bushes.

Hardened, ground and permanently-lubricated pins. Clamp nuts on lever arm to vary friction in movement. Material: steel, blued.

Lever arm made of cast steel, blued. Handle of red, oil-resistant plastic.

Complete with tempered, galvanized clamping screw no. 6885.



CAD

Order no.	Size	F1 [kN]	Clamping screw	Weight [g]
91330	2	2,5	M 6x 50	320
90902	4	10,0	M12x 80	1320
90910	6	12,0	M12x110	2120
90928	8	20,0	M12x110	4060

Note:

These heavy vertical toggle clamps are especially suitable for production equipment and fixtures.

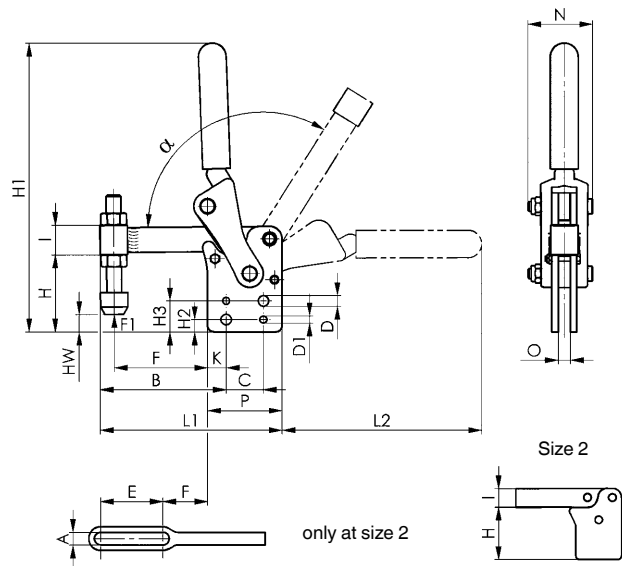

Recommendations



No. 6802,
page 16



No. 6806,
page 22



No. 6811P,
page 26

Dimensions:

Order no.	Size	A	B	C	D	D1	E	F	H	H1	H2	H3	HW min.	HW max.	I	K	L1	L2	N	O	P	α
91330	2	6,2	48	-	-	-	30	12	42,0	144	-	-	3,5	22,8	15	-	85	94	31	6	37	120°
90902	4	12,2	101	30	8,5	5,7	-	75	62,0	233	10	25	-1,0	35,0	24	15	146	161	52	10	60	120°
90910	6	12,2	121	45	10,5	7,7	-	95	87,5	289	15	35	0,0	58,0	30	15	181	189	60	12	75	120°
90928	8	12,2	151	55	12,5	9,7	-	120	106,0	338	15	40	25,0	76,0	36	20	226	219	76	16	95	120°

No. 6809P

Modular clamp

with swivelling foot, welding version.

Mechanism can be welded at an angle to its support.

Reamed and case-hardened bearing bushes.

Hardened, ground and permanently-lubricated pins.

Clamp nuts on lever arm to vary friction in movement.

Materials: steel, blued. Lever arm made of cast steel, blued.



CAD

Order no.	Size	F1		Weight [g]
		[kN]		
90738	2	2,5		205
90746	4	7,0		855
90753	6	11,0		1600
90761	8	22,5		3100
90779	10	34,0		5560

Note:

These modular clamps can be supplemented with accessories just as you need to meet the requirements of your production equipment and fixtures.

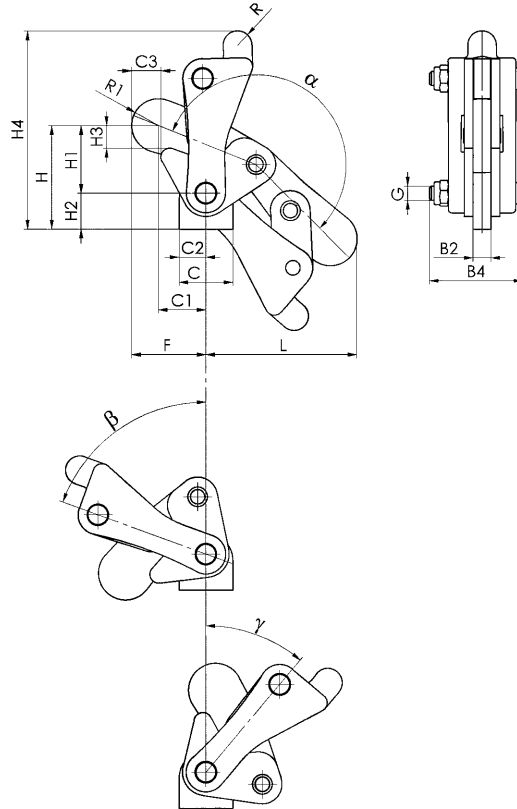

Installation instruction:

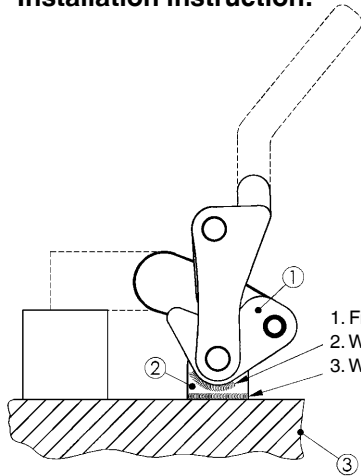

1. Fix modular clamp in clamping position
2. Weld part ① to part ②
3. Weld part ② to part ③

Recommendations



No. 6809H,
page 30

No. 6809RK,
page 30

No. 6809RL,
page 30

Dimensions:

Order no.	Size	B2	B4	C	C1	C2	C3	F	G	H	H1	H2	H3	H4	L	R	R1	α	β	γ
90738	2	6	31	22	22	11	12	32	M 6	38	18	20,0	5	76	58	5	10,0	200°	70°	40°
90746	4	10	52	30	26	15	16	41	M 8	58	38	20,0	12	112	82	8	15,0	200°	70°	40°
90753	6	12	60	36	36	18	20	55	M10	78	50	28,0	16	145	105	11	18,0	200°	70°	40°
90761	8	16	76	50	50	25	27	72	M12	98	65	33,0	19	172	135	14	22,5	200°	70°	40°
90779	10	20	90	70	52	35	22	77	M16	117	83	33,5	25	210	155	14	25,0	200°	60°	28°

Subject to technical alterations.

No. 6810P

Modular clamp

with vertical foot, welding version.

Reamed and case-hardened bearing bushes.

Hardened, ground and permanently-lubricated pins.

Clamp nuts on lever arm to vary friction in movement.

Materials: steel, blued. Lever arm made of cast steel, blued.



CAD

Order no.	Size	F1 [kN]	Weight [g]
90803	2	2,5	245
90811	4	7,0	970
90829	6	11,0	1750
90837	8	22,5	3310
90845	10	34,0	5970

Note:

These modular clamps can be supplemented with accessories just as you need to meet the requirements of your production equipment and fixtures.

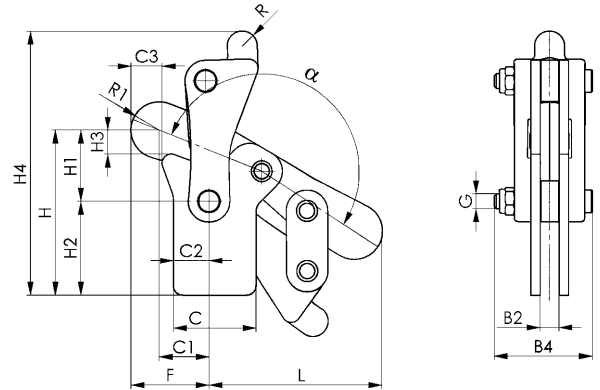

Recommendations



No. 6809G,
page 31



No. 6809S,
page 31



No. 6809V,
page 31

Dimensions:

Order no.	Size	B2	B4	C	C1	C2	C3	F	G	H	H1	H2	H3	H4	L	R	R1	α
90803	2	6	31	30	22	14	12	32	M 6	52	18	34	5	90	58	5	10,0	190°
90811	4	10	52	44	26	19	16	41	M 8	88	38	50	12	142	82	8	15,0	190°
90829	6	12	60	55	36	28	20	55	M10	114	50	64	16	182	106	11	18,0	190°
90837	8	16	76	66	50	37	27	72	M12	140	64	76	19	218	135	14	22,5	190°
90845	10	20	90	80	52	40	22	77	M16	173	83	90	25	266	155	14	25,0	190°

Subject to technical alterations.

No. 6809H

Hand grip

Red, oil-resistant plastic.



CAD

Order no.	Size	ØD x H	Weight [g]
91355	2	13 x 50	7
91363	4	18 x 90	21
91371	6	22 x 100	28
91389	8+10	28 x 110	39

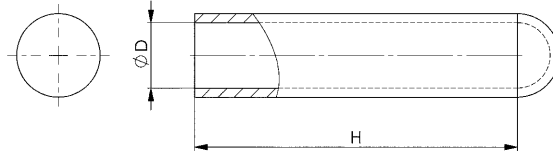

No. 6809RK

Lever arm tube, short

For welding, chamfered to protect operator's hands.
Steel, blued.



CAD

Order no.	Size	ØD x H	Weight [g]
91033	2	13 x 55	37
91041	4	18 x 95	104
91058	6	22 x 105	148
91066	8+10	28 x 115	148

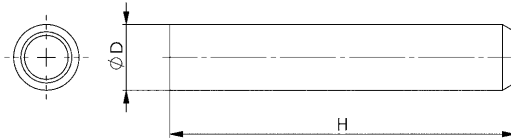

No. 6809RL

Lever arm tube, long

For welding, chamfered to protect operator's hands.
Steel, blued.



CAD

Order no.	Size	ØD x H	Weight [g]
91074	2	13 x 95	60
91082	4	18 x 120	132
91090	6	22 x 150	211
91108	8+10	28 x 180	333

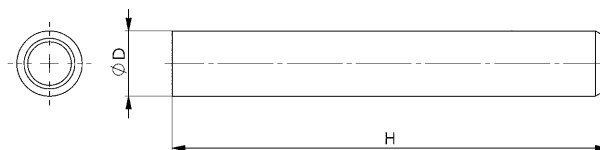

Subject to technical alterations.

No. 6809G

Base plate

For welding, with mounting holes. Steel, blued.



CAD

Order no.	Size	C	dia. D	M	N	P	S	Weight [g]
90944	2+4	25	6,5	35	50	40	8	86
90951	6	40	8,5	30	50	60	8	211
90969	8	50	8,5	45	65	70	8	333
90977	10	60	10,5	50	70	80	10	406

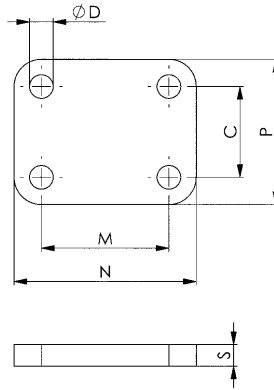

No. 6809S

Clamping screw holder

For welding, thick-walled. Steel, blued.



CAD

Order no.	Size	ØD x H	Weight [g]
91116	2	6,5 x 20	26
91124	4	12,1 x 24	50
91132	6	12,1 x 30	63
91173	8+10	12,1 x 36	75

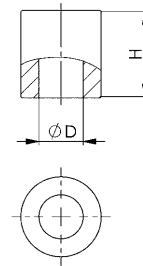

No. 6809V

Clamping arm extension

For welding, slotted. Steel, blued.



CAD

Order no.	Size	L x H x W	Weight [g]
90985	2	40 x 15 x 15	81
90993	4	48 x 25 x 20	208
91009	6	60 x 30 x 25	390
91017	8	75 x 35 x 30	676
91025	10	94 x 35 x 35	970

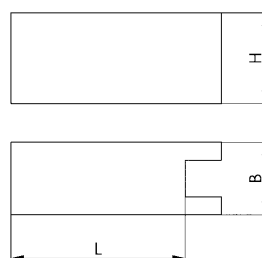

No. 6830

Horizontal toggle clamp with red handle with open clamping arm and horizontal base.

Galvanized and passivated. Rivets made of stainless steel, which, for sizes 2 to 6, run in hardened bushings. Bearings are pre-lubricated.

Ergonomic, oil-resistant handle with large grip surface and soft components. Lock washer for the thrust bolt at the end of the clamping arm.

Complete with tempered, galvanized clamping screw no. 6890.



Order no.	Size	F1 [kN]	F2 [kN]	Clamping screw	Weight [g]
93005	0	0,25	0,4	M4x25	35
93013	1	0,8	1,1	M5x30	105
93021	2	1,0	1,2	M6x35	185
93039	3	1,8	2,5	M8x45	320
93047	4	2,0	3,0	M8x65	700
93054	5	3,0	5,0	M8x65	1080
561275	6	4,00	7,0	M10x116	1925

Also available in „STAINLESS STEEL“ version (no. 6830NI) and in matte-black version (no. 6830B)!

Note:

For suitable sensor monitor for size 3 see no. 6897S.

No. 6830Y

Horizontal toggle clamp with yellow handle



Order no.	Size	F1 [kN]	F2 [kN]	Clamping screw	Weight [g]
557038	0	0,25	0,4	M4x25	35
557039	1	0,8	1,1	M5x30	105
557040	2	1,0	1,2	M6x35	185
557041	3	1,8	2,5	M8x45	320
557042	4	2,0	3,0	M8x65	700
557043	5	3,0	5,0	M8x65	1080
561276	6	4,0	7,0	M10x116	1925

Also available in „STAINLESS STEEL“ version (no. 6830NIY).

No. 6830J

Horizontal toggle clamp with orange handle



Order no.	Size	F1 [kN]	F2 [kN]	Clamping screw	Weight [g]
557331	0	0,25	0,4	M4x25	35
557332	1	0,8	1,1	M5x30	105
557333	2	1,0	1,2	M6x35	185
557334	3	1,8	2,5	M8x45	320
557335	4	2,0	3,0	M8x65	700
557336	5	3,0	5,0	M8x65	1080
561277	6	4,0	7,0	M10x116	1925

Also available in „STAINLESS STEEL“ version (no. 6830NIJ).

No. 6830E

Horizontal toggle clamp with blue handle



Order no.	Size	F1 [kN]	F2 [kN]	Clamping screw	Weight [g]
557655	0	0,25	0,4	M4x25	35
557656	1	0,8	1,1	M5x30	105
557657	2	1,0	1,2	M6x35	185
557658	3	1,8	2,5	M8x45	320
557659	4	2,0	3,0	M8x65	700
557660	5	3,0	5,0	M8x65	1080
561278	6	4,0	7,0	M10x116	1925

Also available in „STAINLESS STEEL“ version (no. 6830NIE).

No. 6830G

Horizontal toggle clamp with green handle



Order no.	Size	F1 [kN]	F2 [kN]	Clamping screw	Weight [g]
557492	0	0,25	0,4	M4x25	35
557493	1	0,8	1,1	M5x30	105
557494	2	1,0	1,2	M6x35	185
557495	3	1,8	2,5	M8x45	320
557496	4	2,0	3,0	M8x65	700
557497	5	3,0	5,0	M8x65	1080
561279	6	4,0	7,0	M10x116	1925

Also available in „STAINLESS STEEL“ version (no. 6830NIG).

No. 6830T

Horizontal toggle clamp with black handle



Order no.	Size	F1 [kN]	F2 [kN]	Clamping screw	Weight [g]
557991	0	0,25	0,4	M4x25	35
557992	1	0,8	1,1	M5x30	105
557993	2	1,0	1,2	M6x35	185
557994	3	1,8	2,5	M8x45	320
557995	4	2,0	3,0	M8x65	700
557996	5	3,0	5,0	M8x65	1080
561280	6	4,0	7,0	M10x116	1925

Also available in „STAINLESS STEEL“ version (no. 6830NIT).

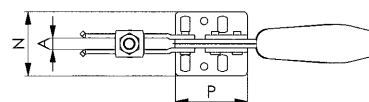
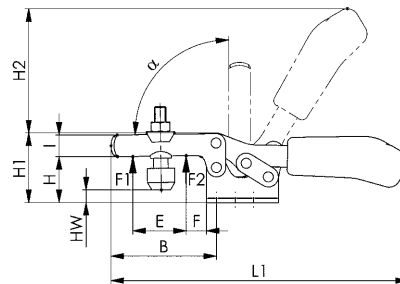
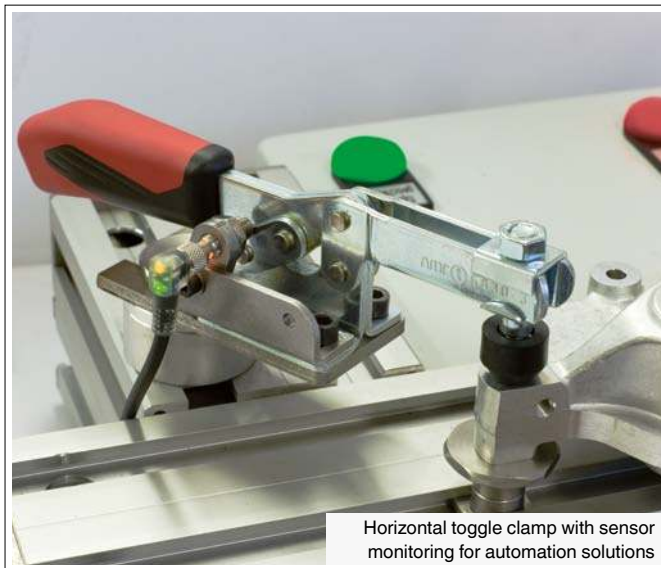

Size 0

Size 1

Size 2, 3, 4

Size 5

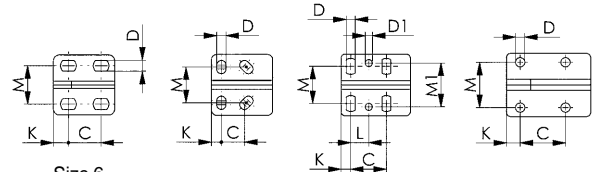

Size 6

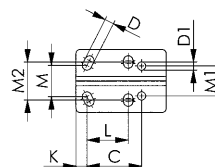

Recommendations



No. 6860,
page 44



No. 6897S,
page 162



No. 6830S,
page 74

Dimensions:

Size	A	B	C	D	D1	E	F	H	H1	H2	HW min.	HW max.	I	K	L	L1	M	M1	M2	N	P	α
0	4	28	11,5-15,5	4,6	-	9,0	5,5	14,5	23,0	34	-5,5	0,0	7,5	6,3	-	79	16,0	-	-	25,0	25,5	90°
1	5	42	13,0-14,5	5,2	-	18,7	8,0	19,0	30,0	49	-3,0	2,5	10,0	5,5	-	120	18,0-21,5	-	-	34,0	34,0	90°
2	6	64	26,0	5,6	5,6	32,0	16,0	24,0	45,0	68	-1,5	5,0	13,2	6,0	12,7	162	19,5-29,5	28,5	-	42,0	38,0	90°
3	8	73	25,7	6,5	5,1	38,0	14,0	32,0	48,5	86	-2,0	9,0	15,0	7,0	13,0	206	22,0-31,8	31,6	-	45,5	50,0	90°
4	10	113	41,0	8,5	8,5	63,0	27,0	45,0	75,0	126	-4,0	24,0	20,0	8,0	20,5	287	29,0-43,0	43,0	-	58,0	57,0	90°
5	10	123	41,5	8,5	-	78,0	16,0	46,0	73,0	128	+1,7	25,0	25,0	12,5	-	321	41,5	-	-	58,0	77,0	90°
6	10	110	57,7	9,8	8,7	59,3	20,6	71,5	114,5	181	-6,0	44,0	30,0	11,5	43,6	354	32,1-43,8	31,6	-	66,5	95,0	83°

Subject to technical alterations.

No. 68300

Horizontal toggle clamp plus with red handle

With increased clamping force, open clamping arm and horizontal base.

Galvanised and passivated. Stainless steel rivets. The bearings are pre-lubricated. Ergonomic, oil-resistant handle with large grip surface and soft components. Safety clamping piece with lock washer for the clamping screw at the end of the clamping arm.

Complete with tempered, galvanised clamping screw no. 68301.



Order no.	Size	F1 [kN]	F2 [kN]	Clamping screw	Weight [g]
552552	1	1,1	1,7	M5 x 35	114
551715	2	1,6	3,0	M6 x 50	450
551716	3	2,5	4,0	M8 x 58	560
551717	4	3,5	8,0	M10 x 76	1250

Also available in „STAINLESS STEEL“ version (no. 68300NI).

No. 68300Y

Horizontal toggle clamp plus with yellow handle



Order no.	Size	F1 [kN]	F2 [kN]	Clamping screw	Weight [g]
557046	1	1,1	1,7	M5 x 35	114
557930	2	1,6	3,0	M6 x 50	450
557047	3	2,5	4,0	M8 x 58	560
557048	4	3,5	8,0	M10 x 76	1250

Also available in „STAINLESS STEEL“ version (no. 68300NIY).

No. 68300J

Horizontal toggle clamp plus with orange handle



Order no.	Size	F1 [kN]	F2 [kN]	Clamping screw	Weight [g]
557337	1	1,1	1,7	M5 x 35	114
557935	2	1,6	3,0	M6 x 50	450
557338	3	2,5	4,0	M8 x 58	560
557339	4	3,5	8,0	M10 x 76	1250

Also available in „STAINLESS STEEL“ version (no. 68300NIJ).

No. 68300E

Horizontal toggle clamp plus with blue handle

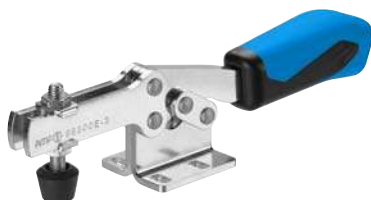

Order no.	Size	F1 [kN]	F2 [kN]	Clamping screw	Weight [g]
557668	1	1,1	1,7	M5 x 35	114
557937	2	1,6	3,0	M6 x 50	450
557669	3	2,5	4,0	M8 x 58	560
557670	4	3,5	8,0	M10 x 76	1250

Also available in „STAINLESS STEEL“ version (no. 68300NIE).

No. 68300G

Horizontal toggle clamp plus with green handle



Order no.	Size	F1 [kN]	F2 [kN]	Clamping screw	Weight [g]
557498	1	1,1	1,7	M5 x 35	114
557936	2	1,6	3,0	M6 x 50	450
557499	3	2,5	4,0	M8 x 58	560
557500	4	3,5	8,0	M10 x 76	1250

Also available in „STAINLESS STEEL“ version (no. 68300NIG).

No. 68300T

Horizontal toggle clamp plus with black handle



Order no.	Size	F1 [kN]	F2 [kN]	Clamping screw	Weight [g]
557997	1	1,1	1,7	M5 x 35	114
557998	2	1,6	3,0	M6 x 50	450
557999	3	2,5	4,0	M8 x 58	560
558000	4	3,5	8,0	M10 x 76	1250

Also available in „STAINLESS STEEL“ version (no. 68300NIT).

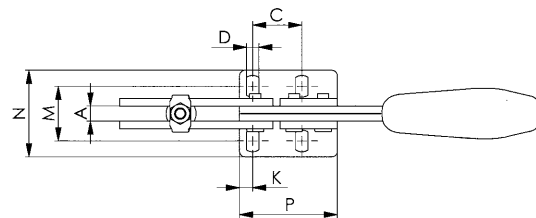
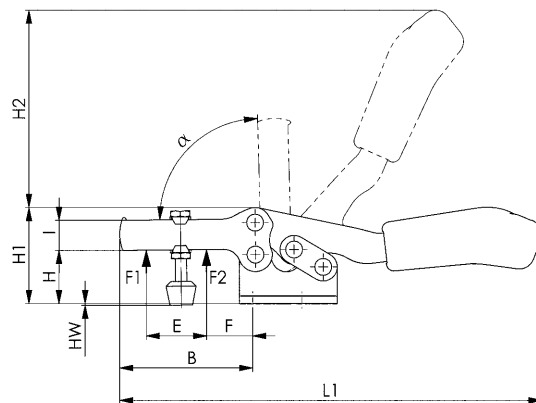

Recommendations



No. 68301,
page 165



No. 6830S,
page 74



No. 6800,
page 12

Dimensions:

Size	A	B	C	D	E	F	H	H1	H2	HW min.	HW max.	I	K	L1	M	N	P	α
1	5	46	13,5	4,3	20	16,5	19,0	35	46	0	10,0	12	6,0	126	15,0 - 19,5	27,5	34,0	90°
2	8	71	26,0	6,5	39	14,0	28,0	51	108	-1	12,0	16	7,0	224	23,5 - 34,0	46,0	52,0	90°
3	8	78	26,0	6,5	43	22,0	33,5	58	112	-1	13,0	18	6,5	242	25,5 - 36,0	47,0	52,5	90°
4	10	120	41,5	8,6	69	23,0	41,0	77	135	-2	16,5	24	10,5	329	34,5 - 45,0	60,0	76,0	90°

Subject to technical alterations.

No. 6832

Horizontal toggle clamp with red handle

with open clamping arm and vertical base.

Galvanized and passivated. Rivets made of stainless steel, which, for sizes 2 to 5, run in hardened bushings. Bearings are pre-lubricated.

Ergonomic, oil-resistant handle with large grip surface and soft components. Lock washer for the thrust bolt at the end of the clamping arm.

Complete with tempered, galvanized clamping screw no. 6890.



Order no.	Size	F1 [kN]	F2 [kN]	Clamping screw	Weight [g]
93203	0	0,25	0,4	M4x25	35
93211	1	0,8	1,1	M5x30	105
93229	2	1,0	1,2	M6x35	185
93237	3	1,8	2,5	M8x45	320
93245	4	2,0	3,0	M8x65	700
93252	5	3,0	5,0	M8x65	1080

Also available in matte-black version (no. 6832B)!

No. 6832Y

Horizontal toggle clamp with yellow handle



Order no.	Size	F1 [kN]	F2 [kN]	Clamping screw	Weight [g]
557097	0	0,25	0,4	M4x25	35
557098	1	0,8	1,1	M5x30	105
557099	2	1,0	1,2	M6x35	185
557100	3	1,8	2,5	M8x45	320
557101	4	2,0	3,0	M8x65	700
557102	5	3,0	5,0	M8x65	1080

No. 6832J

Horizontal toggle clamp with orange handle



Order no.	Size	F1 [kN]	F2 [kN]	Clamping screw	Weight [g]
557340	0	0,25	0,4	M4x25	35
557341	1	0,8	1,1	M5x30	105
557342	2	1,0	1,2	M6x35	185
557343	3	1,8	2,5	M8x45	320
557344	4	2,0	3,0	M8x65	700
557345	5	3,0	5,0	M8x65	1080

No. 6832E

Horizontal toggle clamp with blue handle



Order no.	Size	F1 [kN]	F2 [kN]	Clamping screw	Weight [g]
557671	0	0,25	0,4	M4x25	35
557672	1	0,8	1,1	M5x30	105
557673	2	1,0	1,2	M6x35	185
557674	3	1,8	2,5	M8x45	320
557675	4	2,0	3,0	M8x65	700
557676	5	3,0	5,0	M8x65	1080

No. 6832G

Horizontal toggle clamp with green handle



Order no.	Size	F1 [kN]	F2 [kN]	Clamping screw	Weight [g]
557501	0	0,25	0,4	M4x25	35
557502	1	0,8	1,1	M5x30	105
557503	2	1,0	1,2	M6x35	185
557504	3	1,8	2,5	M8x45	320
557505	4	2,0	3,0	M8x65	700
557506	5	3,0	5,0	M8x65	1080

No. 6832T

Horizontal toggle clamp with black handle



Order no.	Size	F1 [kN]	F2 [kN]	Clamping screw	Weight [g]
558010	0	0,25	0,4	M4x25	35
558011	1	0,8	1,1	M5x30	105
558012	2	1,0	1,2	M6x35	185
558013	3	1,8	2,5	M8x45	320
558014	4	2,0	3,0	M8x65	700
558015	5	3,0	5,0	M8x65	1080

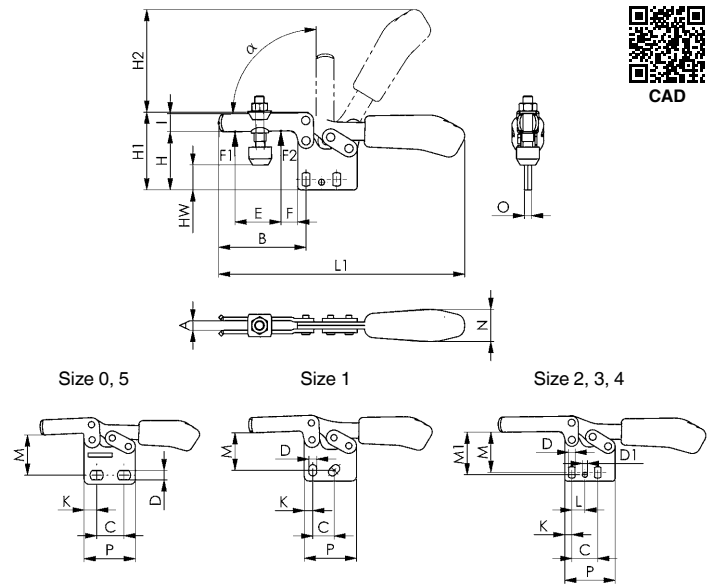

Recommendations



Dimensions:

Size	A	B	C	D	D1	E	F	H	H1	H2	HW min.	HW max.	I	K	L	L1	M	M1	N	O	P	α
0	4	28	11,5-15,5	4,6	-	9,0	5	24,5	33,0	34	4,7	10,7	7,5	6,3	-	79	20,0	-	12	3	25,5	90°
1	5	42	13,0-14,5	5,2	-	18,5	8	31,5	43,0	49	8,0	15,0	10,0	5,5	-	120	23,5-25,5	-	18	5	34,0	90°
2	6	64	26,0	5,6	5,6	32,0	16	40,0	61,0	68	15,0	22,0	13,2	6,0	12,7	164	29,5-34,0	34,0	21	5	38,0	90°
3	8	73	25,7	6,5	5,1	38,5	14	49,0	65,0	86	14,5	26,0	15,0	7,0	13,0	206	37,5-42,5	42,0	27	6	50,0	90°
4	10	113	41,0	8,5	8,5	63,0	27	66,5	97,0	115	17,5	46,0	20,0	8,0	20,5	287	52,0-59,0	59,0	34	8	57,0	90°
5	10	123	41,5	8,5	-	78,0	16	65,0	92,5	128	21,5	45,0	25,0	12,5	-	321	57,0	-	36	10	77,0	90°

Subject to technical alterations.

No. 6833

Horizontal toggle clamp with red handle with open clamping arm and angle base.

Galvanized and passivated. Rivets made of stainless steel, which, for sizes 2 and 3, run in hardened bushings. Bearings are pre-lubricated.

Ergonomic, oil-resistant handle with large grip surface and soft components. Lock washer for the thrust bolt at the end of the clamping arm.

Complete with tempered, galvanized clamping screw no. 6890.

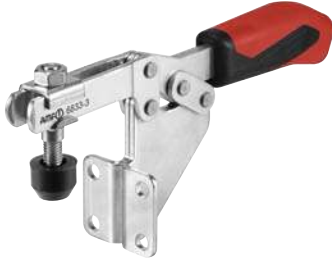

Order no.	Size	F1 [kN]	F2 [kN]	Clamping screw	Weight [g]
93179	1	0,8	1,1	M5x30	170
93328	2	1,0	1,2	M6x35	245
93336	3	1,8	2,5	M8x45	390
93542	4	2,0	3,0	M8x65	730

No. 6833Y

Horizontal toggle clamp with yellow handle



Order no.	Size	F1 [kN]	F2 [kN]	Clamping screw	Weight [g]
557118	1	0,8	1,1	M5x30	170
557119	2	1,0	1,2	M6x35	245
557120	3	1,8	2,5	M8x45	390
557121	4	2,0	3,0	M8x65	730

No. 6833J

Horizontal toggle clamp with orange handle



Order no.	Size	F1 [kN]	F2 [kN]	Clamping screw	Weight [g]
557350	1	0,8	1,1	M5x30	170
557351	2	1,0	1,2	M6x35	245
557352	3	1,8	2,5	M8x45	390
557353	4	2,0	3,0	M8x65	730

No. 6833E

Horizontal toggle clamp with blue handle



Order no.	Size	F1 [kN]	F2 [kN]	Clamping screw	Weight [g]
557682	1	0,8	1,1	M5x30	170
557683	2	1,0	1,2	M6x35	245
557684	3	1,8	2,5	M8x45	390
557685	4	2,0	3,0	M8x65	730

Subject to technical alterations.

No. 6833G

Horizontal toggle clamp with green handle

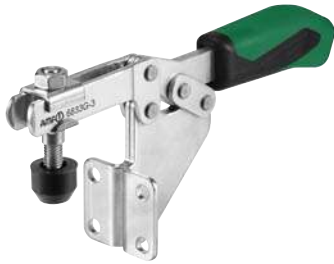

Order no.	Size	F1 [kN]	F2 [kN]	Clamping screw	Weight [g]
557511	1	0,8	1,1	M5x30	170
557512	2	1,0	1,2	M6x35	245
557513	3	1,8	2,5	M8x45	390
557514	4	2,0	3,0	M8x65	730

No. 6833T

Horizontal toggle clamp with black handle

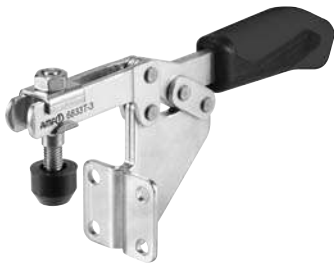

Order no.	Size	F1 [kN]	F2 [kN]	Clamping screw	Weight [g]
558021	1	0,8	1,1	M5x30	170
558022	2	1,0	1,2	M6x35	245
558023	3	1,8	2,5	M8x45	390
558024	4	2,0	3,0	M8x65	730



CAD

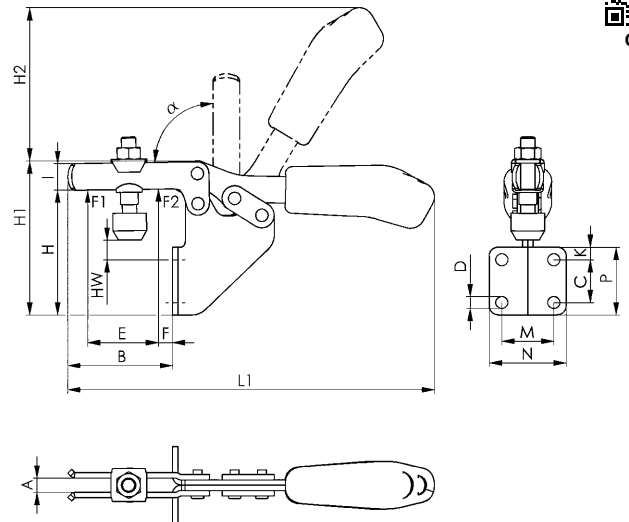

Recommendations



No. 6896,
page 171



No. 6895,
page 178



No. 6830,
page 32

Dimensions:

Size	A	B	C	D	E	F	H	H1	H2	HW min.	HW max.	I	K	L1	M	N	P	α
1	5,0	32	13,5	5,2	18,5	4,0	57	68,0	49	14	20,0	10,0	8	120	19,0	31,0	28	90°
2	6,2	52	20,0	5,6	32,0	10,5	73	94,0	68	22	29,5	13,2	6	162	25,5	37,0	32	90°
3	8,0	59	24,0	6,8	37,0	6,5	70	86,5	86	5	16,0	15,0	7	206	28,5	42,5	38	90°
4	10,0	93	32,0	8,5	63,0	15,0	102	133,0	120	11	40,0	20,0	40	282	32,0	52,0	82	90°

Subject to technical alterations.

No. 6834

Horizontal toggle clamp with red handle

with solid arm and horizontal base.

Galvanized and passivated.

Stainless steel rivets, which run in hardened bushes.

Bearings are pre-lubricated.

Ergonomic, oil-resistant handle with large grip surface and soft components.

Complete with tempered, galvanized clamping screw no. 6885 and sleeve to weld on.



Order no.	Size	F1 [kN]	F2 [kN]	Clamping screw	Weight [g]
93427	2	1,0	1,2	M 6x35	185
93435	3	1,8	2,5	M 8x45	320
93443	4	2,0	3,0	M 8x65	700
93450	5	3,0	5,0	M12x80	1080

Note:

For suitable sensor monitor for size 3 see no. 6897S.

No. 6834Y

Horizontal toggle clamp with yellow handle



Order no.	Size	F1 [kN]	F2 [kN]	Clamping screw	Weight [g]
557106	2	1,0	1,2	M 6x35	185
557108	3	1,8	2,5	M 8x45	320
557109	4	2,0	3,0	M 8x65	700
557110	5	3,0	5,0	M12x80	1080

No. 6834J

Horizontal toggle clamp with orange handle



Order no.	Size	F1 [kN]	F2 [kN]	Clamping screw	Weight [g]
557346	2	1,0	1,2	M 6x35	185
557347	3	1,8	2,5	M 8x45	320
557348	4	2,0	3,0	M 8x65	700
557349	5	3,0	5,0	M12x80	1080

No. 6834E

Horizontal toggle clamp with blue handle



Order no.	Size	F1 [kN]	F2 [kN]	Clamping screw	Weight [g]
557678	2	1,0	1,2	M 6x35	185
557679	3	1,8	2,5	M 8x45	320
557680	4	2,0	3,0	M 8x65	700
557681	5	3,0	5,0	M12x80	1080

No. 6834G

Horizontal toggle clamp with green handle



Order no.	Size	F1 [kN]	F2 [kN]	Clamping screw	Weight [g]
557507	2	1,0	1,2	M 6x35	185
557508	3	1,8	2,5	M 8x45	320
557509	4	2,0	3,0	M 8x65	700
557510	5	3,0	5,0	M12x80	1080

No. 6834T

Horizontal toggle clamp with black handle



Order no.	Size	F1 [kN]	F2 [kN]	Clamping screw	Weight [g]
558017	2	1,0	1,2	M 6x35	185
558018	3	1,8	2,5	M 8x45	320
558019	4	2,0	3,0	M 8x65	700
558020	5	3,0	5,0	M12x80	1080

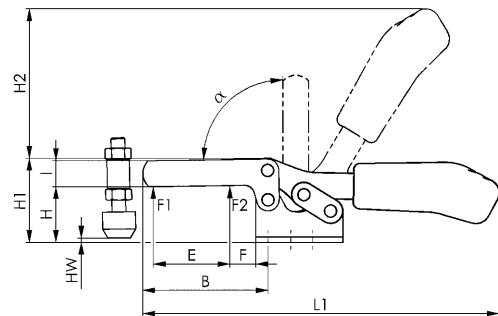

CAD

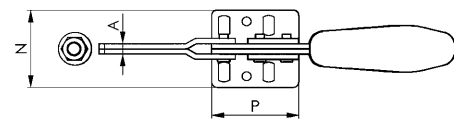

Size 2, 3, 4

Size 5

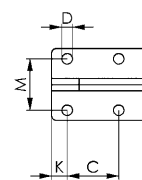
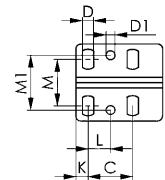

Recommendations



No. 6886,
page 168



No. 6804,
page 20



No. 6834S,
page 78

Dimensions:

Size	A	B	C	D	D1	E	F	H	H1	H2	HW min.	HW max.	I	K	L	L1	M	M1	N	P	α
2	5	63	26,0	5,6	5,6	35	16,0	24	45,0	66	-2,0	7,5	13	6,0	12,7	161	19,5-29,5	28,5	42	38	90°
3	6	72	26,0	6,5	5,1	44	15,0	32	48,5	86	-3,5	11,0	15	7,0	13,0	205	22,0-31,8	32,0	45,5	50	90°
4	8	111	41,0	8,5	8,5	66	26,0	45	75,0	114	-6,0	22,0	20	8,0	20,5	280	29,0-43,0	43,0	58	57	90°
5	10	121	41,5	8,5	-	78	17,5	46	73,0	128	-13,0	12,5	25	12,5	-	320	41,5	-	58	77	90°

Subject to technical alterations.

No. 6837M

Horizontal acting toggle clamp

For removable handle.

To prevent interference during use, the handle can be removed after opening or closing this horizontal acting toggle clamp.

With open clamping arm and horizontal base. Galvanized and passivated. Stainless steel rivets. The bearings are pre-lubricated.

Handle 6837H is not included in delivery and needs to be ordered separately.

Complete with tempered, galvanised clamping screw no. 6890.



Order no.	Size	F1 [kN]	F2 [kN]	Clamping screw	Weight [g]
93948	2	1,0	1,2	M6 x 35	160
94201	3	1,8	2,5	M8 x 45	269
94268	4	2,0	3,0	M8 x 65	608

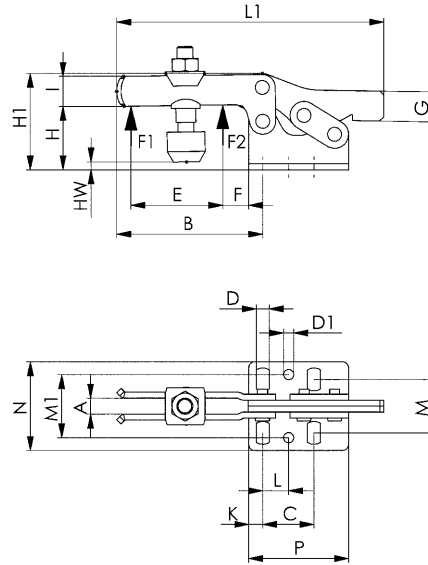

Recommendations



No. 6830S,
page 74



No. 6896,
page 171



No. 6895,
page 178

Dimensions:

Order no.	Size	A	B	C	D	D1	E	F	G	H	H1	HW min.	HW max.	I	K	L	L1	M	M1	N	P	α
93948	2	6	64	26,0	5,6	5,6	32	16	12	24	45,0	-1,5	5	13,2	6	12,7	113	19,5 - 29,5	28,5	42,0	38	90°
94201	3	8	73	25,7	6,5	5,1	38	14	15	32	48,5	-2,0	9	15,0	7	13,0	134	22,0 - 31,8	31,6	45,5	50	90°
94268	4	10	113	41,5	8,5	8,5	63	27	15	45	75,0	-4,0	24	20,0	8	20,5	191	29,0 - 43,0	43,0	58,0	57	90°

No. 6837H

Red handle, removable

For horizontal acting toggle clamp no. 6837M.



Order no.	Size	H	L	N	Weight [g]
94144	2	26	93,0	21,0	70
94284	3	35	118,5	27,0	122
94292	4	42	134,5	34,5	195

No. 6837HY

Yellow handle, removable



Order no.	Size	H	L	N	Weight [g]
557125	2	26	93,0	21,0	70
557126	3	35	118,5	27,0	122
557127	4	42	134,5	34,5	195

No. 6837HJ

Orange handle, removable



Order no.	Size	H	L	N	Weight [g]
557357	2	26	93,0	21,0	70
557358	3	35	118,5	27,0	122
557359	4	42	134,5	34,5	195

No. 6837HE

Blue handle, removable



Order no.	Size	H	L	N	Weight [g]
557686	2	26	93,0	21,0	70
557687	3	35	118,5	27,0	122
557688	4	42	134,5	34,5	195

No. 6837HG

Green handle, removable



Order no.	Size	H	L	N	Weight [g]
557525	2	26	93,0	21,0	70
557526	3	35	118,5	27,0	122
557527	4	42	134,5	34,5	195

No. 6837HT

Black handle, removable



Order no.	Size	H	L	N	Weight [g]
558025	2	26	93,0	21,0	70
558026	3	35	118,5	27,0	122
558027	4	42	134,5	34,5	195

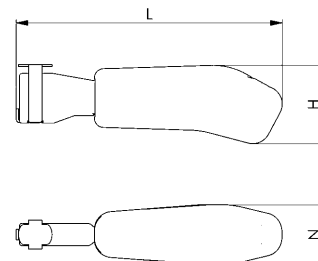

CAD

POSITIONING AND CLAMPING AT THE SAME TIME AND IN ONE OPERATION

The benefits at a glance:

- > Positioning and clamping in one operation
- > Robust and stable design
- > Workpiece easy to remove thanks to the fully retracted clamping arm
- > Optimised quality consistent with the AMF quality standard

Precise positioning and reliable clamping of individual components are of paramount importance when welding fixtures. In practice, this is guaranteed through the simultaneous use of rods and vertical toggle clamps, or by one's own complex design. The AMF Combiclamp accomplishes these two tasks in one operation, eliminating the need to use different toggle clamps. The sliding block guide on the Combiclamp converts the motion of the lever arm into a horizontal and vertical clamping movement, through which the workpiece is positioned and clamped at the same time.

See for yourself the saving potential of using the new AMF Combiclamp!

PRESENT FIXTURE:



SET-UP WITH AMF-COMBICLAMP:



No. 6860

Combination clamp with red handle

Galvanized and passivated.
Rivets made of stainless steel which run in hardened bushings.
Bearings are pre-lubricated.
Ergonomic, oil-resistant handle with large grip surface and soft components.



Order no.	Size	F1 [kN]	F2 [kN]	Weight [g]
93831	1	1,0	1,0	340
93880	2	2,0	2,0	700
93864	3	3,0	3,0	1620

No. 6860Y

Combination clamp with yellow handle



Order no.	Size	F1 [kN]	F2 [kN]	Weight [g]
557143	1	1,0	1,0	340
557144	2	2,0	2,0	700
557145	3	3,0	3,0	1620

No. 6860J

Combination clamp with orange handle



Order no.	Size	F1 [kN]	F2 [kN]	Weight [g]
557360	1	1,0	1,0	340
557361	2	2,0	2,0	700
557362	3	3,0	3,0	1620

Subject to technical alterations.

No. 6860E

Combination clamp with blue handle



Order no.	Size	F1 [kN]	F2 [kN]	Weight [g]
557689	1	1,0	1,0	340
557690	2	2,0	2,0	700
557691	3	3,0	3,0	1620

No. 6860G

Combination clamp with green handle



Order no.	Size	F1 [kN]	F2 [kN]	Weight [g]
557528	1	1,0	1,0	340
557529	2	2,0	2,0	700
557530	3	3,0	3,0	1620

No. 6860T

Combination clamp with black handle



Order no.	Size	F1 [kN]	F2 [kN]	Weight [g]
558028	1	1,0	1,0	340
558029	2	2,0	2,0	700
558030	3	3,0	3,0	1620

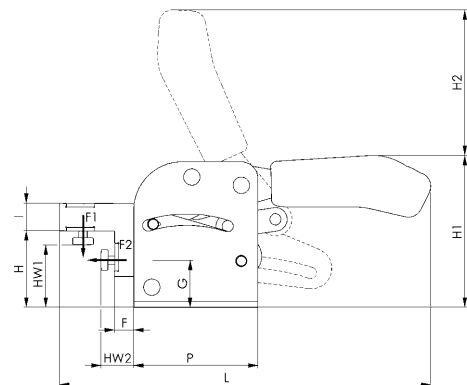

Recommendations



No. 6841,
page 46

No. 6830,
page 32

No. 6860P,
page 135

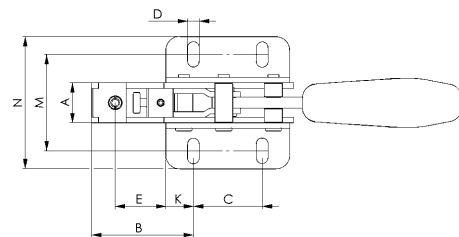

Dimensions:

Size	A	B	C	D	E	F	G	H	H1	H2	HW1 min.	HW1 max.	HW2 min.	HW2 max.	I	K	L	M	N	P
1	17,0	33	40	5,5	15	0,5	22	36,0	74	62	25	32	5	10	12	7,5	150	34,5-39,5	53	55
2	19,5	56	50	6,5	32	9,0	28	46,0	94	87	30	40	14	24	16	12,5	219	48,5-61,5	75	75
3	29,0	74	50	8,5	37	14,0	34	55,5	110	106	40	50	20	30	20	20,0	270	60,0-80,0	96	90

No. 6841

Push-pull type toggle clamp with red handle

with small angle base. For push- and pull-clamping. (Equal operation of rod and lever). Long rod-guide with attaching thread and nut. Galvanized and passivated. Rivets made of stainless steel, which, for sizes 2 and 3, run in hardened bushings. Lever-parts and rod of tempered steel. Bearings are pre-lubricated. Lever can be set to any angle relative to base. Ergonomic, oil-resistant handle with large grip surface and soft components. Complete with tempered, galvanized clamping screw no. 6880.



Order no.	Size	F1 [kN]	F2 [kN]	Clamping screw	Weight [g]
94094	0	0,8	0,8	M 4x20	65
94110	1	1,0	1,0	M 4x20	125
94128	2	2,0	2,0	M 6x25	245
94136	3	2,5	2,5	M 8x35	445
94151	5	4,5	4,5	M12x50	880
94367	5-M27	4,5	4,5	M12x50	900

Also available in „STAINLESS STEEL“ version (no. 6841NI) and in matte-black version (no. 6841B)!

No. 6841Y

Push-pull type toggle clamp with yellow handle



Order no.	Size	F1 [kN]	F2 [kN]	Clamping screw	Weight [g]
557147	0	0,8	0,8	M 4x20	65
557148	1	1,0	1,0	M 4x20	125
557149	2	2,0	2,0	M 6x25	245
557150	3	2,5	2,5	M 8x35	445
557151	5	4,5	4,5	M12x50	880
557152	5-M27	4,5	4,5	M12x50	900

Also available in „STAINLESS STEEL“ version (no. 6841NIY).

No. 6841J

Push-pull type toggle clamp with orange handle



Order no.	Size	F1 [kN]	F2 [kN]	Clamping screw	Weight [g]
557373	0	0,8	0,8	M 4x20	65
557374	1	1,0	1,0	M 4x20	125
557375	2	2,0	2,0	M 6x25	245
557376	3	2,5	2,5	M 8x35	445
557377	5	4,5	4,5	M12x50	880
557378	5-M27	4,5	4,5	M12x50	900

Also available in „STAINLESS STEEL“ version (no. 6841NIJ).

No. 6841E

Push-pull type toggle clamp with blue handle



Order no.	Size	F1 [kN]	F2 [kN]	Clamping screw	Weight [g]
557692	0	0,8	0,8	M 4x20	65
557693	1	1,0	1,0	M 4x20	125
557694	2	2,0	2,0	M 6x25	245
557695	3	2,5	2,5	M 8x35	445
557696	5	4,5	4,5	M12x50	880
557697	5-M27	4,5	4,5	M12x50	900

Also available in „STAINLESS STEEL“ version (no. 6841NIE).

No. 6841G

Push-pull type toggle clamp with green handle



Order no.	Size	F1 [kN]	F2 [kN]	Clamping screw	Weight [g]
557531	0	0,8	0,8	M 4x20	65
557532	1	1,0	1,0	M 4x20	125
557533	2	2,0	2,0	M 6x25	245
557534	3	2,5	2,5	M 8x35	445
557535	5	4,5	4,5	M12x50	880
557536	5-M27	4,5	4,5	M12x50	900

Also available in „STAINLESS STEEL“ version (no. 6841NIG).

No. 6841T

Push-pull type toggle clamp with black handle



Order no.	Size	F1 [kN]	F2 [kN]	Clamping screw	Weight [g]
558031	0	0,8	0,8	M 4x20	65
558032	1	1,0	1,0	M 4x20	125
558033	2	2,0	2,0	M 6x25	245
558034	3	2,5	2,5	M 8x35	445
558035	5	4,5	4,5	M12x50	880
558036	5-M27	4,5	4,5	M12x50	900

Also available in „STAINLESS STEEL“ version (no. 6841NIT).

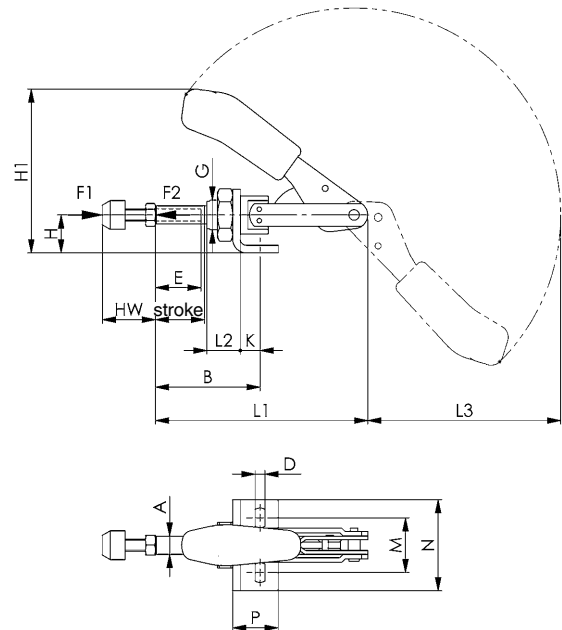

CAD

Recommendations



No. 6844,
page 50



No. 6845,
page 52



No. 6842,
page 54

Dimensions:

Size	A	B min.	B max.	D	E	G	H	H1	Stroke	HW min.	HW max.	K	L1	L2	L3	M	N	P
0	6,5	17,0	33,0	4,5	13	M10x1,0	12	49,3	16	12	20	6,5	66,5	10	54,0	16,0	25	16
1	8,0	24,5	44,5	4,5	20	M12x1,5	15	60,5	20	12	20	7,0	91,0	16	74,0	16,0-19,5	30	20
2	10,0	32,5	58,5	5,6	20	M16x1,5	20	85,5	26	17	25	12,5	114,0	19	105,0	31,8-36,0	50	34
3	12,0	37,0	69,0	6,5	30	M20x1,5	25	108,0	32	22	35	13,0	140,0	22	127,5	29,5-42,5	60	30
5	16,0	41,5	81,5	8,5	50	M24x1,5	30	129,5	40	30	50	15,5	171,5	25	158,0	29,0-46,0	65	35
5-M27	16,0	41,5	81,5	8,5	50	M27x2,0	30	129,5	40	30	50	15,5	171,5	25	158,0	29,0-46,0	65	35

Subject to technical alterations.

No. 6840

Push-pull type toggle clamp with red handle

without angle base. For push- and pull-clamping. (Equal operation of rod and lever).

Long rod-guide with attaching thread and nut. Galvanized and passivated. Rivets made of stainless steel, which, for sizes 2 and 3, run in hardened bushings. Lever-parts and rod of tempered steel. Bearings are pre-lubricated. Push-pull toggle clamp with threaded front for direct mounting in vertical metal plates or in fixtures. Ergonomic, oil-resistant handle with large grip surface and soft components.

Complete with tempered, galvanized clamping screw no. 6880.



Order no.	Size	F1 [kN]	F2 [kN]	Clamping screw	Weight [g]
93906	0	0,8	0,8	M 4x20	60
93914	1	1,0	1,0	M 4x20	100
93922	2	2,0	2,0	M 6x25	245
93930	3	2,5	2,5	M 8x35	330
93955	5	4,5	4,5	M12x50	700
94359	5-M27	4,5	4,5	M12x50	720

No. 6840Y

Push-pull type toggle clamp with yellow handle



Order no.	Size	F1 [kN]	F2 [kN]	Clamping screw	Weight [g]
557161	0	0,8	0,8	M 4x20	60
557162	1	1,0	1,0	M 4x20	100
557163	2	2,0	2,0	M 6x25	245
557164	3	2,5	2,5	M 8x35	330
557165	5	4,5	4,5	M12x50	700
557166	5-M27	4,5	4,5	M12x50	720

No. 6840J

Push-pull type toggle clamp with orange handle



Order no.	Size	F1 [kN]	F2 [kN]	Clamping screw	Weight [g]
557389	0	0,8	0,8	M 4x20	60
557390	1	1,0	1,0	M 4x20	100
557391	2	2,0	2,0	M 6x25	245
557392	3	2,5	2,5	M 8x35	330
557393	5	4,5	4,5	M12x50	700
557394	5-M27	4,5	4,5	M12x50	720

No. 6840E

Push-pull type toggle clamp with blue handle



Order no.	Size	F1 [kN]	F2 [kN]	Clamping screw	Weight [g]
557699	0	0,8	0,8	M 4x20	60
557700	1	1,0	1,0	M 4x20	100
557701	2	2,0	2,0	M 6x25	245
557702	3	2,5	2,5	M 8x35	330
557703	5	4,5	4,5	M12x50	700
557704	5-M27	4,5	4,5	M12x50	720

No. 6840G

Push-pull type toggle clamp with green handle



Order no.	Size	F1 [kN]	F2 [kN]	Clamping screw	Weight [g]
557537	0	0,8	0,8	M 4x20	60
557538	1	1,0	1,0	M 4x20	100
557539	2	2,0	2,0	M 6x25	245
557540	3	2,5	2,5	M 8x35	330
557541	5	4,5	4,5	M12x50	700
557542	5-M27	4,5	4,5	M12x50	720

No. 6840T

Push-pull type toggle clamp with black handle



Order no.	Size	F1 [kN]	F2 [kN]	Clamping screw	Weight [g]
558037	0	0,8	0,8	M 4x20	60
558038	1	1,0	1,0	M 4x20	100
558039	2	2,0	2,0	M 6x25	245
558040	3	2,5	2,5	M 8x35	330
558041	5	4,5	4,5	M12x50	700
558042	5-M27	4,5	4,5	M12x50	720

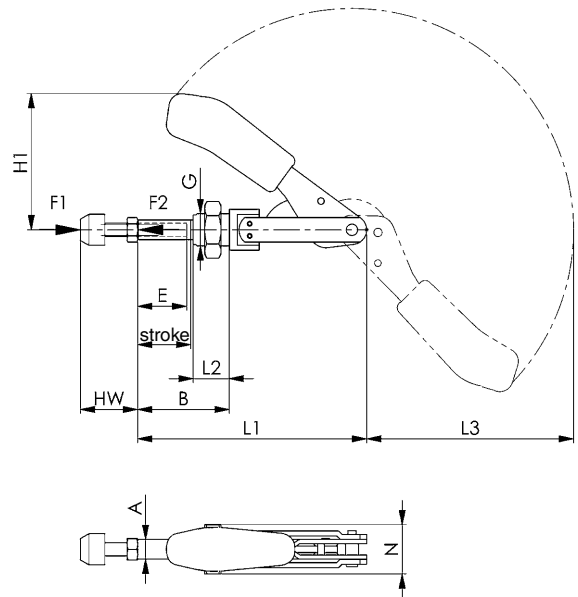
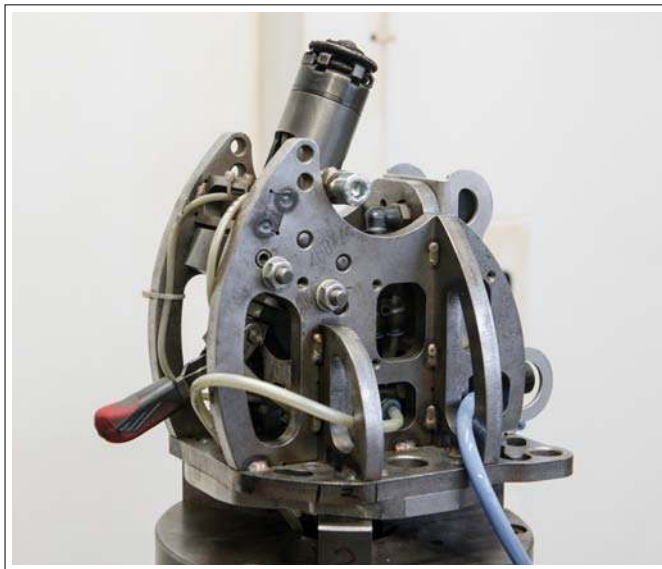

CAD

Recommendations



No. 6843,
page 52



No. 6841,
page 46



No. 6840S,
page 80

Dimensions:

Size	A	B min.	B max.	E	G	H1	Stroke	HW min.	HW max.	L1	L2	L3	N
0	6,5	10,5	26,5	13	M10x1,0	37,0	16	12	20	66,5	10	54	17
1	8,0	17,5	37,5	20	M12x1,5	45,5	20	12	20	91,0	16	74	19
2	10,0	20,0	46,0	20	M16x1,5	66,0	26	17	25	114,0	19	105	24
3	12,0	24,0	56,0	30	M20x1,5	82,5	32	22	35	140,0	22	127	30
5	16,0	26,5	66,5	50	M24x1,5	99,0	40	30	50	171,5	25	158	36
5-M27	16,0	26,5	66,5	50	M27x2,0	99,0	40	30	50	171,5	25	158	41

Subject to technical alterations.

No. 6844

Push-pull type toggle clamp with red handle

short version. For push- and pull-clamping.
 Long rod-guide with attaching thread and nut.
 Galvanized and passivated. Stainless steel rivet. Shoulder screws tempered. Bearings are pre-lubricated.
 Ergonomic, oil-resistant handle with large grip surface and soft components.
Complete with tempered, galvanized clamping screw no. 6880.



Order no.	Size	F1 [kN]	F2 [kN]	Clamping screw	Weight [g]
94300	2	1,0	1,0	M 6x25	130
94318	3	2,5	2,5	M 8x35	320
94334	5	4,0	4,0	M12x50	1200
92676	5-M27	4,0	4,0	M12x50	1200

Also available in „STAINLESS STEEL“ version (no. 6844NI).

Application:

Toggle for direct fit up in metal plates or fixtures, using its front attaching thread or by means of solid base angle no. 6843.

No. 6844Y

Push-pull type toggle clamp with yellow handle



Order no.	Size	F1 [kN]	F2 [kN]	Clamping screw	Weight [g]
557167	2	1,0	1,0	M 6x25	130
557168	3	2,5	2,5	M 8x35	320
557169	5	4,0	4,0	M12x50	1200
557170	5-M27	4,0	4,0	M12x50	1200

Also available in „STAINLESS STEEL“ version (no. 6844NIY).

No. 6844J

Push-pull type toggle clamp with orange handle



Order no.	Size	F1 [kN]	F2 [kN]	Clamping screw	Weight [g]
557397	2	1,0	1,0	M 6x25	130
557398	3	2,5	2,5	M 8x35	320
557399	5	4,0	4,0	M12x50	1200
557400	5-M27	4,0	4,0	M12x50	1200

Also available in „STAINLESS STEEL“ version (no. 6844NIJ).

No. 6844E

Push-pull type toggle clamp with blue handle



Order no.	Size	F1 [kN]	F2 [kN]	Clamping screw	Weight [g]
557710	2	1,0	1,0	M 6x25	130
557711	3	2,5	2,5	M 8x35	320
557712	5	4,0	4,0	M12x50	1200
557713	5-M27	4,0	4,0	M12x50	1200

Also available in „STAINLESS STEEL“ version (no. 6844NIE).

No. 6844G

Push-pull type toggle clamp with green handle



Order no.	Size	F1 [kN]	F2 [kN]	Clamping screw	Weight [g]
557548	2	1,0	1,0	M 6x25	130
557549	3	2,5	2,5	M 8x35	320
557550	5	4,0	4,0	M12x50	1200
557551	5-M27	4,0	4,0	M12x50	1200

Also available in „STAINLESS STEEL“ version (no. 6844NIG).

No. 6844T

Push-pull type toggle clamp with black handle



Order no.	Size	F1 [kN]	F2 [kN]	Clamping screw	Weight [g]
558046	2	1,0	1,0	M 6x25	130
558047	3	2,5	2,5	M 8x35	320
558048	5	4,0	4,0	M12x50	1200
558049	5-M27	4,0	4,0	M12x50	1200

Also available in „STAINLESS STEEL“ version (no. 6844NIT).

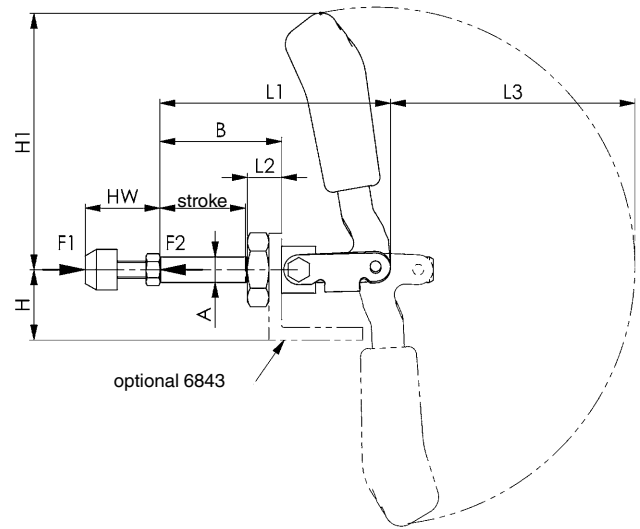
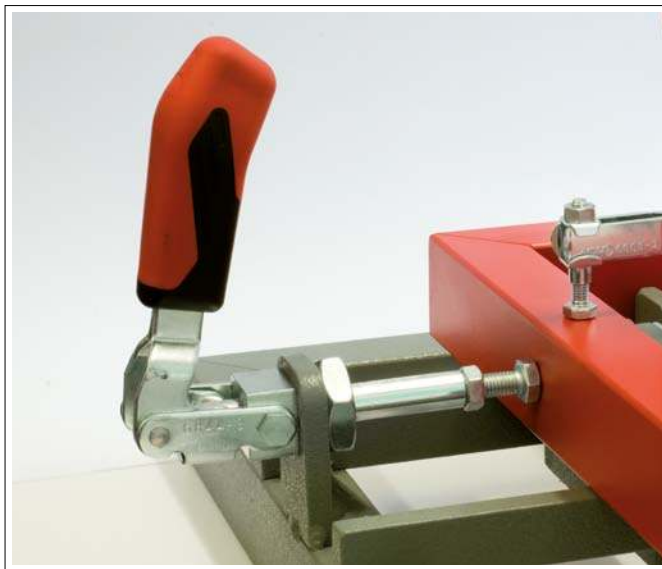

CAD

Recommendations



No. 6843,
page 52



No. 6860,
page 44

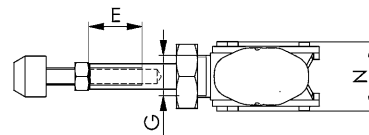

Dimensions:

Size	A	B	E	G	H	H1	Stroke	HW min.	HW max.	L1	L2	L3	N
2	10	36	15	M16x1,5	24	73	21,5	17	25	68,5	13	68	30,5
3	12	57	25	M20x1,5	33	123	40,0	22	35	108,0	16	115	33,0
5	16	92	45	M24x1,5	37	149	67,0	30	50	175,0	24	139	49,0
5-M27	16	92	45	M27x2,0	37	149	67,0	30	50	175,0	24	139	49,0

Subject to technical alterations.

No. 6843

Angle base, solid

for no. 6840 and no. 6844.

Increased range of application due to enlarged height of center line. Fastening by means of 4 screws.



CAD

Order no.	Size	C	D	D1	H	H1	K	M	N	P	T	Weight [g]
94003	0	16,0	4,5	10,2	13	23	9,0	15,5-20,5	30	30	3	35
94011	1	11-18	6,7	12,2	24	40	11,0	40,0	60	40	4	135
94029	2	11-18	6,7	16,2	24	40	11,0	40,0	60	40	5	160
94037	3	19,0	6,7	20,2	33	50	14,5	41,0	65	44	6	235
94052	5	32,0	9,0	24,0	37	60	17,0	45,0	70	60	8	450
94391	5-M27	32,0	9,0	27,0	37	60	17,0	45,0	70	60	8	440

Also available in „STAINLESS STEEL“ version (no. 6843NI).

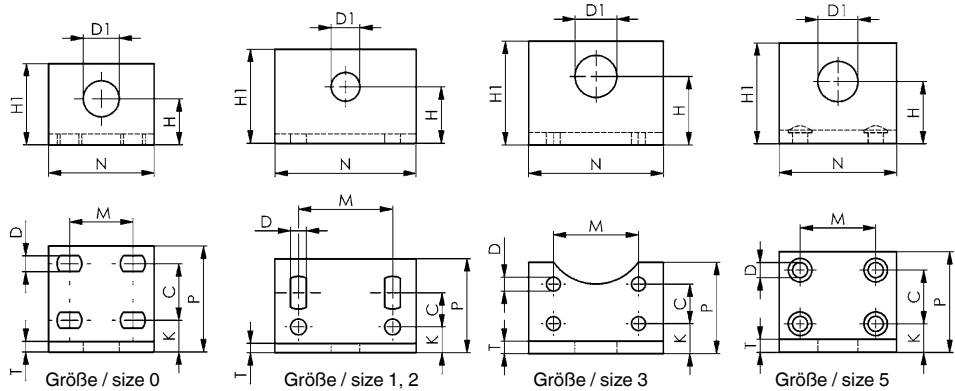

Recommendations



No. 6841, page 46



No. 6840, page 48



No. 6844, page 50

No. 6845

Push-pull type toggle clamp

Push-type clamp.

(Opposed operation of rod and lever). Version with long rod-guide. Base of malleable casting, varnished. Toggle parts and push rod are heat-treated steel, galvanized and passivated. Stainless steel rivets, which run in hardened bushes. Bearings are pre-lubricated. Ergonomic, oil-resistant handle with large grip surface and soft components.

Complete with tempered, galvanized clamping screw no. 6880-3.



CAD

Order no.	Size	F1 [kN]	Clamping screw	Weight [g]
94243	3	4	M8x35	540

Advantage:

- Low height in clamped position
- Compatible with AMF push-pull toggle clamp no. 6842-3

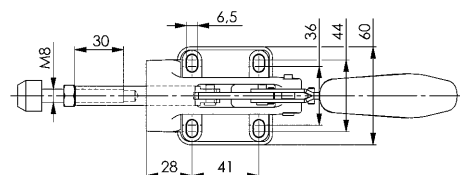
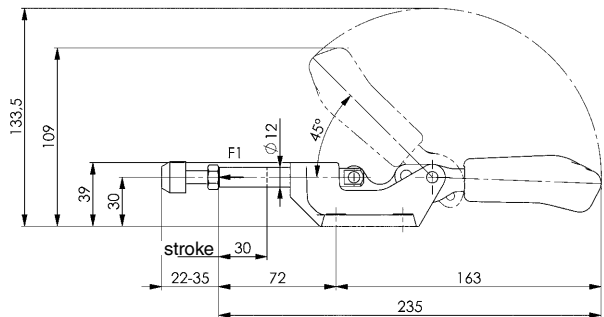

Recommendations



No. 6841, page 46



No. 6842, page 54



No. 6842PK, page 56

Subject to technical alterations.

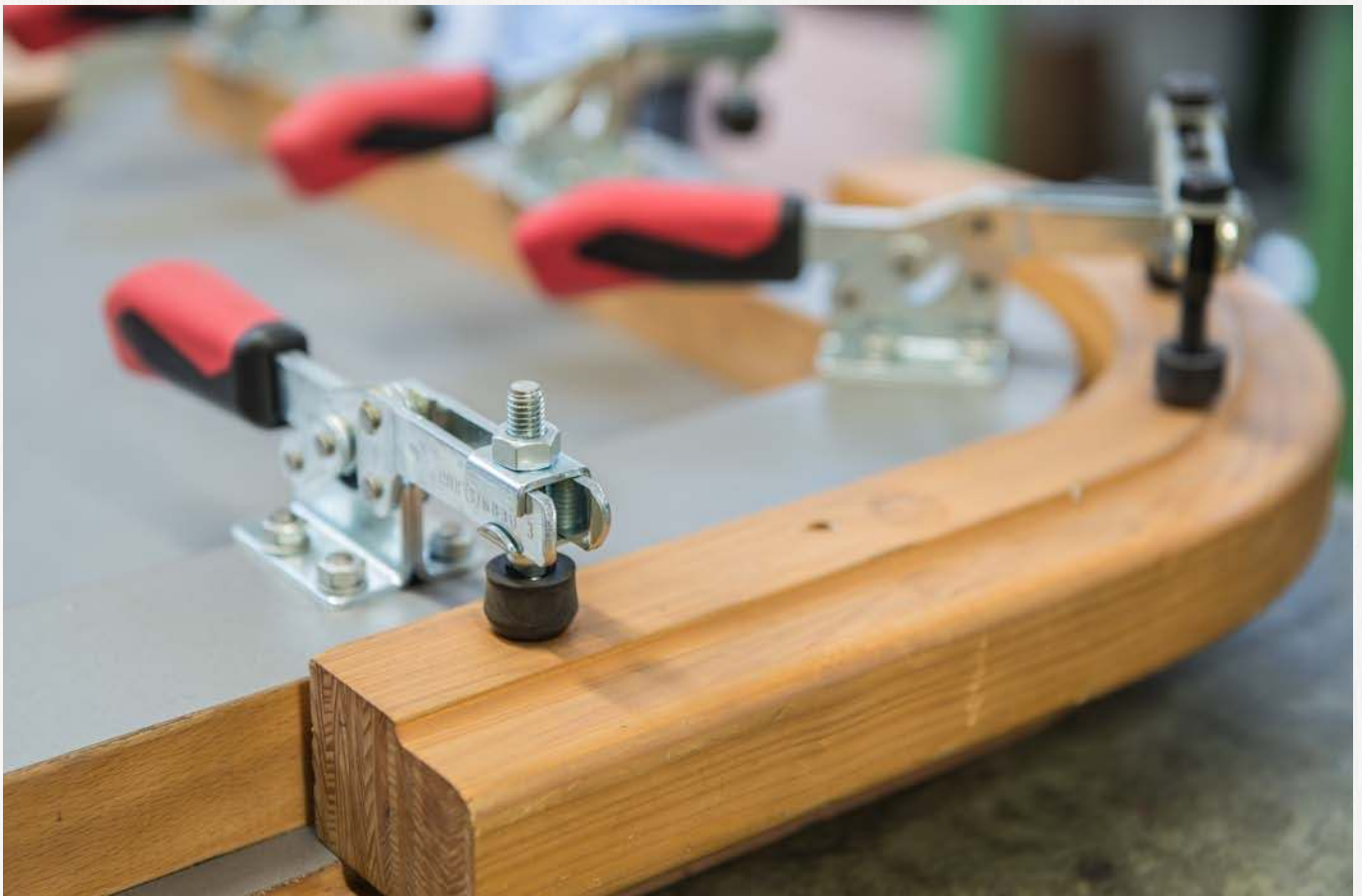
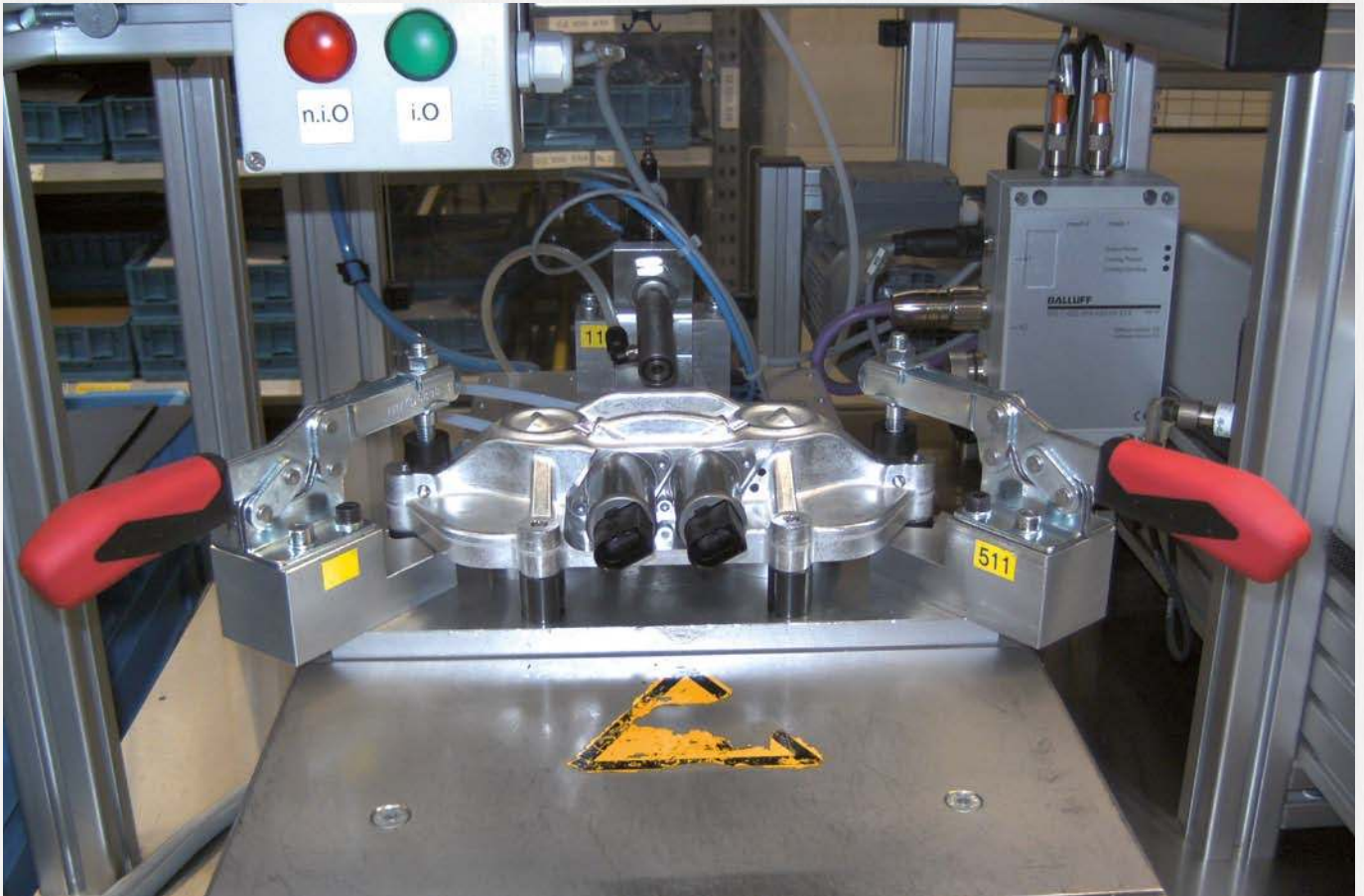

No. 6842

Heavy-duty push-pull type toggle clamp with red handle

For push and pull-clamping.

(Equal operation of rod and lever). Heavy-duty version with long rod-guide. Base (body) made of malleable cast iron, varnished. Lever parts and push rod made of tempered steel, galvanized and passivated. Rivets made of stainless steel, which, for size 3, run in hardened bearing bushes. Bearing positions are greased. Ergonomic, oil-resistant handle with large grip surface and soft components.

Complete with tempered, galvanized clamping screw no. 6880.

Order no.	Size	F1 [kN]	F2 [kN]	Clamping screw	Weight [g]
94235	3	4	4	M 8x35	540
94250	5	10	10	M12x50	1115
94276	7	25	25	M12x50	2840



No. 6842Y

Heavy-duty push-pull type toggle clamp with yellow handle

Order no.	Size	F1 [kN]	F2 [kN]	Clamping screw	Weight [g]
557171	5	10	10	M12x50	1115
557172	7	25	25	M12x50	2840



No. 6842J

Heavy-duty push-pull type toggle clamp with orange handle

Order no.	Size	F1 [kN]	F2 [kN]	Clamping screw	Weight [g]
557403	5	10	10	M12x50	1115
557404	7	25	25	M12x50	2840



No. 6842E

Heavy-duty push-pull type toggle clamp with blue handle

Order no.	Size	F1 [kN]	F2 [kN]	Clamping screw	Weight [g]
557714	5	10	10	M12x50	1115
557715	7	25	25	M12x50	2840



No. 6842G

Heavy-duty push-pull type toggle clamp with green handle



Order no.	Size	F1 [kN]	F2 [kN]	Clamping screw	Weight [g]
557561	5	10	10	M12x50	1115
557562	7	25	25	M12x50	2840

No. 6842T

Heavy-duty push-pull type toggle clamp with black handle



Order no.	Size	F1 [kN]	F2 [kN]	Clamping screw	Weight [g]
558054	5	10	10	M12x50	1115
558055	7	25	25	M12x50	2840

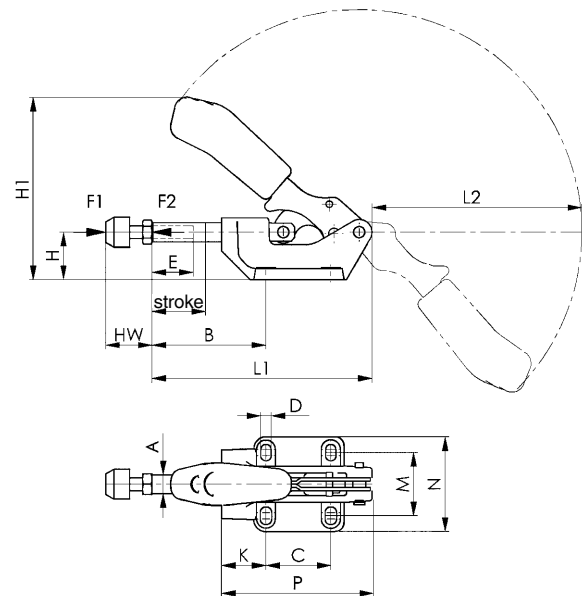

Recommendations



No. 6841,
page 46



No. 6842PL,
page 57



No. 6860,
page 44

Dimensions:

Size	A	B min.	B max.	C	D	E	H	H1	Stroke	HW min.	HW max.	K	L1	L2	M	N	P
3	12	40	72	41	6,5	30	30	116,0	32	22	35	28	139	135	36-44	60	95
5	16	58	98	41	8,5	50	38	137,5	40	30	50	45	174	156	41-50	71	121
7	22	59	105	70	11,0	50	55	179,0	50	30	50	45	218	192	57-65	93	158

Subject to technical alterations.

No. 6842PK

Heavy push-pull type toggle clamp

with solid lever. For push- and pull-clamping.
(Equal operation of rod and lever).

Heavy-duty version with long rod-guide. Base of malleable casting, burnished. Hardened pins. Lever-parts and rod of tempered steel, burnished. Handle made of red, oil-resistant plastic.

Complete with tempered, galvanized clamping screw no. 6880.



Order no.	Size	F1 [kN]	F2 [kN]	Clamping screw	Weight [g]
92544	4	7	7	M 8x35	590
92569	5	12	12	M10x50	1650
92585	7	25	25	M12x50	4150
92601	8	45	45	M16x80	7420

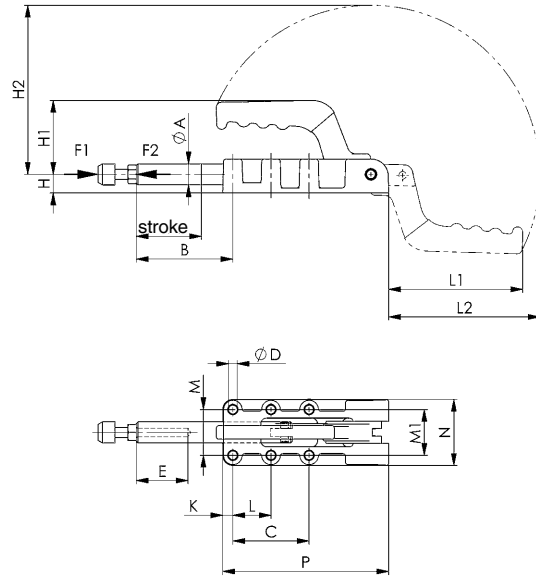
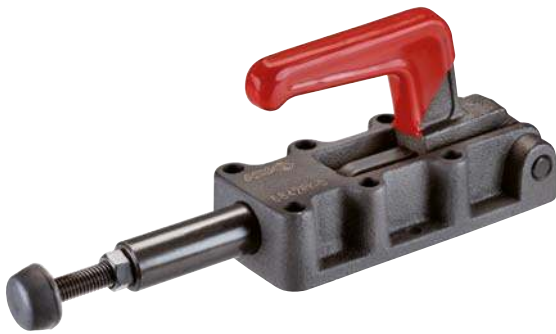

Recommendations



No. 6800,
page 12



No. 6811P,
page 26



No. 6842PL,
page 57

Dimensions:

Order no.	Size	dia. A	B	C	dia. D	E	H	H1	H2	Stroke	K	L	L1	L2	M	M1	N	P
92544	4	14	63	-	5,5	30	12	54	94	32	25	36,5	68,0	85	33,6	33,4	46	90
92569	5	20	63	76	8,5	40	18	70	135	52	8	35,0	106,5	125	42,0	41,0	58	135
92585	7	25	114	90	10,3	61	22	88	200	75	12	45,0	158,5	179	54,0	54,0	78	196
92601	8	30	150	140	10,3	60	28	97	227	106	12	70,0	181,0	202	57,0	57,0	84	254

No. 6842PL

Heavy push-pull type toggle clamp

with reversible lever. For push- and pull-clamping.
(Equal operation of rod and lever).

Heavy-duty version with long rod-guide. Base of malleable casting, burnished. Hardened pins. Lever parts and rod made of tempered steel, burnished. Zinc-coated and passivated lever with handle made of red oil-resistant plastic.

Complete with tempered, galvanized clamping screw no. 6880.



Order no.	Size	F1 [kN]	F2 [kN]	Clamping screw	Weight [g]
92627	4	7	7	M 8x35	650
92643	5	12	12	M10x50	1600
92668	7	25	25	M12x50	4280
92684	8	45	45	M16x80	7720

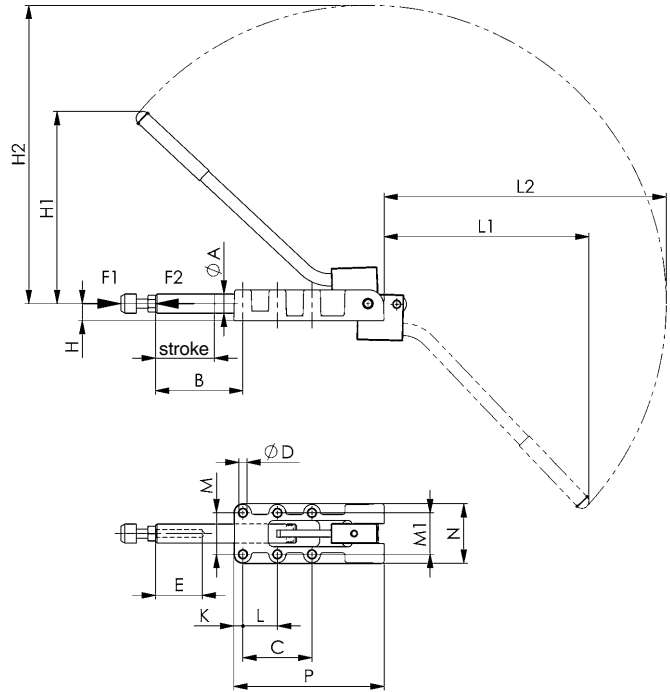

Recommendations



No. 6830,
page 32



No. 6842,
page 54



No. 6842PK,
page 56

Dimensions:

Order no.	Size	dia. A	B	C	dia. D	E	H	H1	H2	Stroke	K	L	L1	L2	M	M1	N	P
92627	4	14	63	-	5,5	30	12	116,5	184,0	32	25	36,5	128	174,5	33,6	33,4	46	90
92643	5	20	63	76	8,5	40	18	178,0	277,5	50	8	35,0	195	266,0	42,0	41,0	58	135
92668	7	25	114	90	10,3	61	22	250,5	389,0	75	12	45,0	267	368,0	54,0	54,0	78	196
92684	8	30	150	140	10,3	66	28	321,5	514,5	106	12	70,0	373	490,5	57,0	57,0	84	254

No. 6847

Hook type toggle clamp

Galvanized and passivated. Bushes case hardened and greased; rivets of stainless steel. Hook and clamping sleeve tempered. Handle made of red, oil-resistant plastic. Ergonomic, oil-resistant handle with large grip surface and soft components for size 1.



Order no.	Size	F1	Adjustm. distance	Weight [g]
		[kN]	[mm]	
94524	1	2	8	100
94540	3	3	12	270
94565	5	5	14	850

Also available in „STAINLESS STEEL“ version (no. 6847NI).

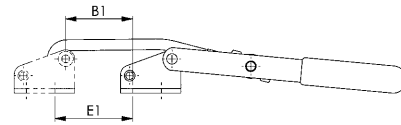
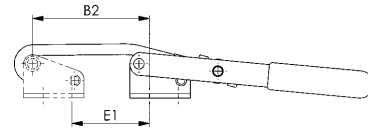
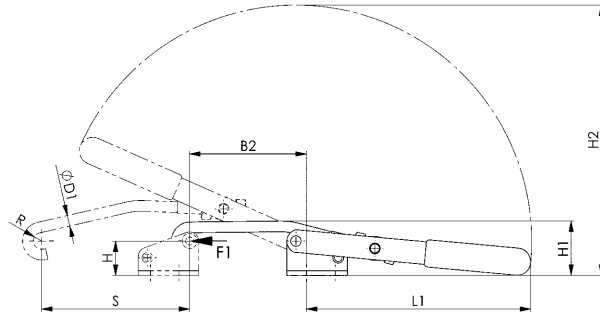
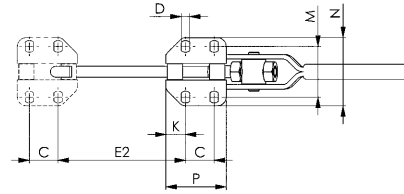

Recommendations



No. 6847S, page 81



No. 6848H, page 60

Dimensions:

Order no.	Size	B1	B2	C	D	dia. D1	E1	E2	H	H1	H2	K	L1	M	N	P	R	S
94524	1	16,0-23,0	35,0-42,0	19	4,5	5,30	16,5-23,5	35,0-42,5	22,7	34,5	111	6	88	25,5-30,5	40	31	4,5	45
94540	3	32,5-44,0	65,5-77,0	19	5,6	7,10	39,5-50,5	72,5-84,0	22,7	36,0	179	13	148	31,0-36,0	45	40	5,5	98
94565	5	26,5-40,0	57,0-71,0	29	11,2	10,75	27,5-42,0	59,5-73,0	49,1	69,0	280	13	228	56,0-63,5	85	55	8,0	146

No. 6847G

Counter catch

for no. 6847. Galvanized and passivated. Bushes case hardened; rivet of stainless steel.



Order no.	Size	Height	Length	Weight [g]
		[mm]	[mm]	
94623	1	29	31	40
94649	3	29	40	70
94664	5	61	55	320

Also available in „STAINLESS STEEL“ version (no. 6847GNI).

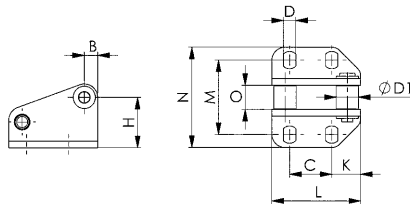

Dimensions:

Order no.	Size	B	C	D	dia. D1	H	K	L	M	N	O
94623	1	6	19	4,5	8	22,7	6	31	26,0-30,0	40	6,9
94649	3	6	19	5,5	10	22,7	13	40	31,3-35,8	45	10,9
94664	5	12	29	11,2	15	49,1	13	55	56,5-64,0	86	13,8

Subject to technical alterations.

No. 6847K

Hook type toggle clamp

for cylindrical mounting surfaces.

Galvanized and passivated. Case-hardened, pre-lubricated, continuous bearing bushes. Stainless steel rivets. Tempered hook and clamping sleeve. Handle made of red, oil-resistant plastic. Use socket cap screws to ISO 4762 (DIN 912) for mounting.



CAD

Order no.	Size	F1 [kN]	Adjustm. distance [mm]	Weight [g]
94680	3	3	22	270

Also available in „STAINLESS STEEL“ version (no. 6847KNI).

Note:

The range of movement can be adjusted by swiveling the base and repositioning the catch.

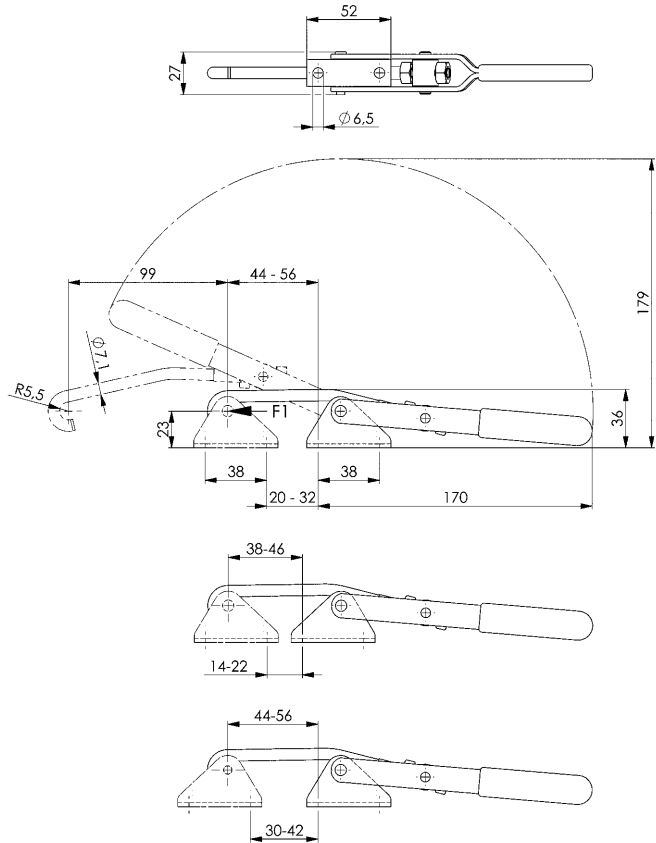

Recommendations



No. 6847S,
page 81



No. 6849PH,
page 64

No. 6847GK

Counter catch

for cylindrical mounting surfaces.

For hook-type toggle clamp no. 6847K. Galvanized and passivated. Case-hardened, continuous bush. Stainless steel rivet. Use socket cap screws to ISO 4762 (DIN 912) for mounting.



CAD

Order no.	Size	Height [mm]	Length [mm]	Weight [g]
94672	3	32	52	65

Also available in „STAINLESS STEEL“ version (no. 6847GKNI).

Note:

The adjustment range of the clamp can be increased by turning the counter catch.

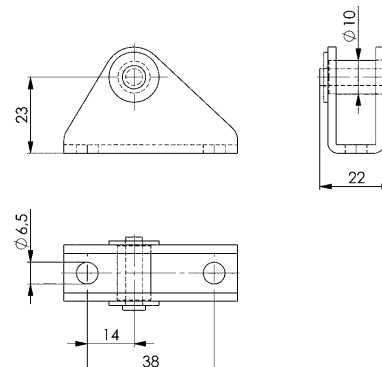

No. 6848H

Horizontal hook-type toggle clamp with red handle

Galvanized and passivated.
Stainless steel rivets, which run in hardened bushes.
Tempered hook. Bearings are pre-lubricated. Ergonomic, oil-resistant handle with large grip surface and soft components.
Supplied complete with counter catch.



Order no.	Size	F1	Weight
		[kN]	
94698	2	1,6	120
94706	3	3,2	330
94714	4	7,0	810

Also available in „STAINLESS STEEL“ version (no. 6848HNI).

No. 6848HY

Horizontal hook-type toggle clamp with yellow handle



Order no.	Size	F1	Weight
		[kN]	
557173	2	1,6	120
557174	3	3,2	330
557175	4	7,0	810

Also available in „STAINLESS STEEL“ version (no. 6848HNIY).

No. 6848HJ

Horizontal hook-type toggle clamp with orange handle



Order no.	Size	F1	Weight
		[kN]	
557405	2	1,6	120
557406	3	3,2	330
557407	4	7,0	810

Also available in „STAINLESS STEEL“ version (no. 6848HNIJ).

No. 6848HE

Horizontal hook-type toggle clamp with blue handle



Order no.	Size	F1	Weight
		[kN]	
557718	2	1,6	120
557719	3	3,2	330
557720	4	7,0	810

Also available in „STAINLESS STEEL“ version (no. 6848HNIIE).

No. 6848HG

Horizontal hook-type toggle clamp with green handle



Order no.	Size	F1		Weight [g]
		[kN]		
557563	2	1,6		120
557564	3	3,2		330
557565	4	7,0		810

Also available in „STAINLESS STEEL“ version (no. 6848HNIG).

No. 6848HT

Horizontal hook-type toggle clamp with black handle



Order no.	Size	F1		Weight [g]
		[kN]		
558056	2	1,6		120
558057	3	3,2		330
558058	4	7,0		810

Also available in „STAINLESS STEEL“ version (no. 6848HNIT).

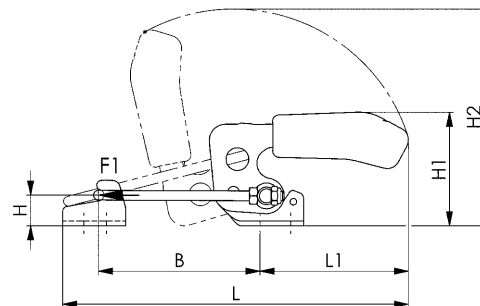
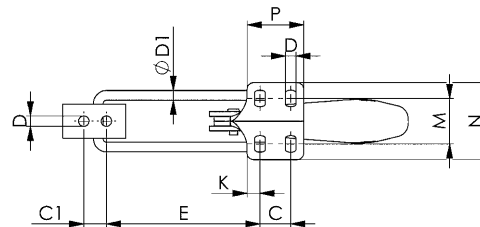

CAD

Recommendations



No. 6847SU,
page 81



No. 6848V,
page 62

Dimensions:

Size	B min.	B max.	C	C1	D	dia. D1	E min.	E max.	H	H1	H2	K	L min.	L max.	L1	M	N	P
2	42,0	76	13	11	5,2	4	38,0	72	12	47,0	99,0	6,4	125	159	69	19,5-23,5	38,0	26,0
3	53,5	101	19	14	6,5	6	48,5	96	19	70,0	136,0	8,0	169	216	93	24,5-32,0	48,0	35,0
4	66,0	130	32	19	8,5	8	59,0	123	26	94,5	168,0	9,5	209	273	111	35,0-46,0	64,5	53,5

Subject to technical alterations.

No. 6848V

Vertical hook-type toggle clamp with red handle

Galvanized and passivated.
Stainless steel rivets, which run in hardened bushes.
Tempered hook. Bearings are pre-lubricated. Ergonomic, oil-resistant handle with large grip surface and soft components.
Supplied complete with counter catch.



Order no.	Size	F1	Weight
		[kN]	
94755	2	1,6	130
94763	3	3,2	340
94771	4	7,0	810

Also available in „STAINLESS STEEL“ version (no. 6848VNI).

No. 6848VY

Vertical hook-type toggle clamp with yellow handle



Order no.	Size	F1	Weight
		[kN]	
557176	2	1,6	130
557177	3	3,2	340
557178	4	7,0	810

Also available in „STAINLESS STEEL“ version (no. 6848VNIY).

No. 6848VJ

Vertical hook-type toggle clamp with orange handle



Order no.	Size	F1	Weight
		[kN]	
557408	2	1,6	130
557409	3	3,2	340
557411	4	7,0	810

Also available in „STAINLESS STEEL“ version (no. 6848VNIJ).

No. 6848VE

Vertical hook-type toggle clamp with blue handle



Order no.	Size	F1	Weight
		[kN]	
557721	2	1,6	130
557722	3	3,2	340
557723	4	7,0	810

Also available in „STAINLESS STEEL“ version (no. 6848VNIIE).

No. 6848VG

Vertical hook-type toggle clamp with green handle



Order no.	Size	F1	Weight [g]
		[kN]	
557566	2	1,6	130
557567	3	3,2	340
557568	4	7,0	810

Also available in „STAINLESS STEEL“ version (no. 6848VNIG).

No. 6848VT

Vertical hook-type toggle clamp with black handle



Order no.	Size	F1	Weight [g]
		[kN]	
558126	2	1,6	130
558127	3	3,2	340
558128	4	7,0	810

Also available in „STAINLESS STEEL“ version (no. 6848VNIT).

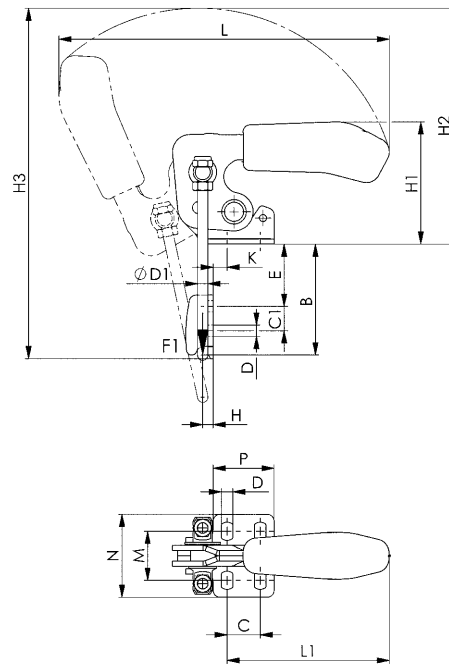

CAD

Recommendations



No. 6847,
page 58



No. 6848H,
page 60



No. 6849PH,
page 64

Dimensions:

Size	B min.	B max.	C	C1	D	dia. D1	E min.	E max.	H	H1	H2	H3	K	L	L1	M	N	P
2	24,0	47	13	11	5,2	4	5,0	28	4,5	47,0	99	150	6,8	158	69	19,5-23,5	38,0	26,0
3	33,0	63	19	14	6,5	6	6,5	36	6,0	70,0	137	172	8,0	190	93	24,5-32,5	48,0	35,0
4	43,0	81	32	19	8,5	8	9,0	47	8,0	94,5	168	254	9,5	239	111	35,0-46,0	64,5	53,5

Subject to technical alterations.

No. 6849PH

Heavy hook type toggle clamp

for high retaining force.

Pins hardened, ground and permanently-lubricated.

Circlips are used to retain pins in bearing bushes, and to centre the clamping pin. Foot, lever arm and catch are made of cast steel and blued. Stirrup, pins and nuts are heat-treated and zinc-plated. Handle grip is red, oil-resistant plastic.

Supplied complete with counter catch.



Order no.	Size	F1	Adjustm. distance	Weight [g]
		[kN]	[mm]	
93849	4	15	66	2830
93856	5	27	65	4020

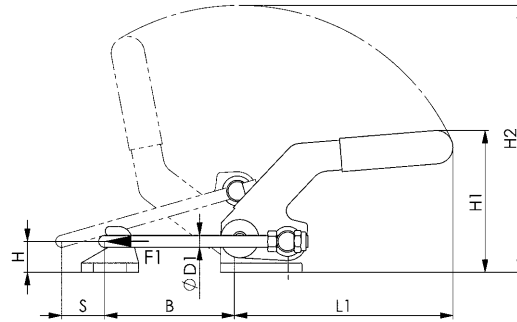
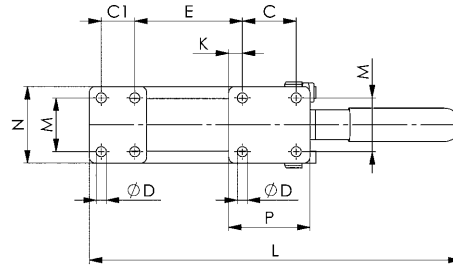

Recommendations



No. 6847K,
page 59



No. 6848H,
page 60



No. 6811P,
page 26

Dimensions:

Order no.	Size	B	C	C1	dia. D1	D	E	H	H1	H2	K	L	L1	M	N	P	S
93849	4	42-107	45	28	8,5	10	24-90	26	122	228	12,0	245-311	183	45	64	68	44
93856	5	49-114	57	35	10,5	12	28-93	32	146	285	12,5	313-378	238	57	82	86	47

Subject to technical alterations.



Subject to technical alterations.

THE ADVANTAGES OF THE SAFETY LATCH

The patented safety latch will hold the clamping arm of a manual clamp in both the closed and open positions, so that it is protected against unintentional opening or closing through vibration or if the clamp is mounted overhead.

A clear argument for safety in the workplace!



No. 6800S

Vertical toggle clamp with red handle and safety latch

for open and clamped positions.

With open clamping arm and horizontal base.

Galvanized and passivated. Stainless steel rivets, which run in hardened bushes. Bearings are pre-lubricated.

Ergonomic, oil-resistant handle with large grip surface and soft components. Safety clamping piece with finger protection. Lock washer for the thrust bolt at the end of the clamping arm.

Complete with tempered, galvanized clamping screw no. 6890.



Order no.	Size	F1 [kN]	F2 [kN]	Clamping screw	Weight [g]
90134	2	0,8	1,2	M6x35	260
90142	3	1,2	2,5	M8x45	470
90159	4	1,7	3,0	M8x65	690

No. 6800SY

Vertical toggle clamp with yellow handle and safety latch



Order no.	Size	F1 [kN]	F2 [kN]	Clamping screw	Weight [g]
557179	2	0,8	1,2	M6x35	260
557180	3	1,2	2,5	M8x45	470
557181	4	1,7	3,0	M8x65	690

No. 6800SJ

Vertical toggle clamp with orange handle and safety latch



Order no.	Size	F1 [kN]	F2 [kN]	Clamping screw	Weight [g]
557417	2	0,8	1,2	M6x35	260
557418	3	1,2	2,5	M8x45	470
557419	4	1,7	3,0	M8x65	690

Subject to technical alterations.

No. 6800SE

Vertical toggle clamp with blue handle and safety latch



Order no.	Size	F1 [kN]	F2 [kN]	Clamping screw	Weight [g]
557724	2	0,8	1,2	M6x35	260
557725	3	1,2	2,5	M8x45	470
557726	4	1,7	3,0	M8x65	690

No. 6800SG

Vertical toggle clamp with green handle and safety latch



Order no.	Size	F1 [kN]	F2 [kN]	Clamping screw	Weight [g]
557569	2	0,8	1,2	M6x35	260
557570	3	1,2	2,5	M8x45	470
557571	4	1,7	3,0	M8x65	690

No. 6800ST

Vertical toggle clamp with black handle and safety latch



Order no.	Size	F1 [kN]	F2 [kN]	Clamping screw	Weight [g]
558129	2	0,8	1,2	M6x35	260
558130	3	1,2	2,5	M8x45	470
558131	4	1,7	3,0	M8x65	690

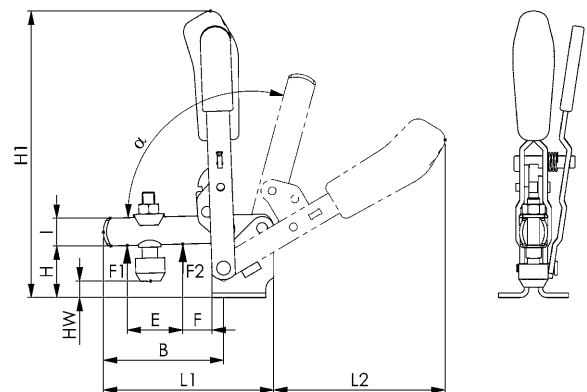

Recommendations



No. 6891,
page 168



No. 6800,
page 12



No. 6860,
page 44

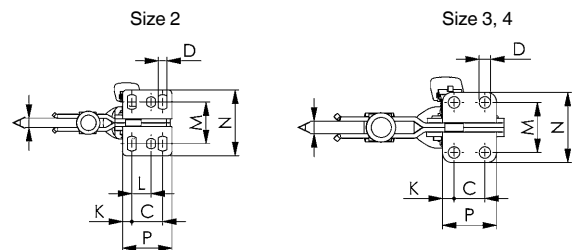

Dimensions:

Size	A	B	C	D	E	F	H	H1	HW min.	HW max.	I	K	L	L1	L2	M	N	P	α	α*
2	6	52	20	5,5	25	11	23,0	139,5	-3	4,5	12	6,0	12,5	78	89	23-31	43	32	105°	60°
3	8	79	20	7,5	36	19	33,0	186,0	2	11,0	18	7,5	-	112	112	32,5	46	35	105°	60°
4	10	101	32	8,6	54	16	42,5	221,0	-6	22,5	20	13,0	-	141	130	45,0	64	53	105°	60°

* The opening angle can be changed by pressing in a stop pin.

Subject to technical alterations.

No. 6802S

Vertical toggle clamp with red handle and safety latch

for open and clamped positions.

With open clamping arm and vertical base.

Galvanized and passivated. Stainless steel rivets, which run in hardened bushes. Bearings are pre-lubricated.

Ergonomic, oil-resistant handle with large grip surface and soft components. Safety clamping piece with finger protection. Lock washer for the thrust bolt at the end of the clamping arm.

Complete with tempered, galvanized clamping screw no. 6890.



Order no.	Size	F1 [kN]	F2 [kN]	Clamping screw	Weight [g]
90209	2	0,8	1,2	M6x35	175
90274	3	1,2	2,5	M8x45	470
90282	4	1,7	3,0	M8x65	690

No. 6802SY

Vertical toggle clamp with yellow handle and safety latch



Order no.	Size	F1 [kN]	F2 [kN]	Clamping screw	Weight [g]
557182	2	0,8	1,2	M6x35	175
557183	3	1,2	2,5	M8x45	470
557184	4	1,7	3,0	M8x65	690

No. 6802SJ

Vertical toggle clamp with orange handle and safety latch



Order no.	Size	F1 [kN]	F2 [kN]	Clamping screw	Weight [g]
557420	2	0,8	1,2	M6x35	175
557421	3	1,2	2,5	M8x45	470
557422	4	1,7	3,0	M8x65	690

No. 6802SE

Vertical toggle clamp with blue handle and safety latch



Order no.	Size	F1 [kN]	F2 [kN]	Clamping screw	Weight [g]
557735	2	0,8	1,2	M6x35	175
557736	3	1,2	2,5	M8x45	470
557737	4	1,7	3,0	M8x65	690

Subject to technical alterations.

No. 6802SG

Vertical toggle clamp with green handle and safety latch



Order no.	Size	F1 [kN]	F2 [kN]	Clamping screw	Weight [g]
557572	2	0,8	1,2	M6x35	175
557573	3	1,2	2,5	M8x45	470
557574	4	1,7	3,0	M8x65	690

No. 6802ST

Vertical toggle clamp with black handle and safety latch



Order no.	Size	F1 [kN]	F2 [kN]	Clamping screw	Weight [g]
558136	2	0,8	1,2	M6x35	175
558137	3	1,2	2,5	M8x45	470
558138	4	1,7	3,0	M8x65	690

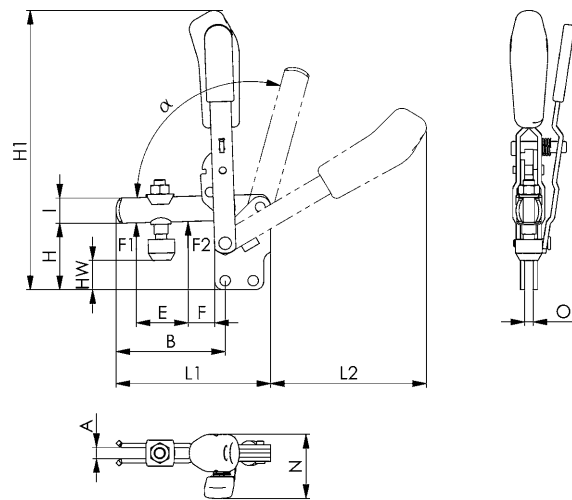

Recommendations



No. 6895,
page 178



No. 6802,
page 16



No. 6820A,
page 138

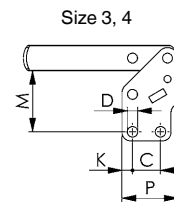
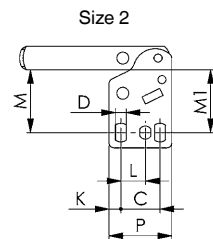

Dimensions:

Size	A	B	C	D	E	F	H	H1	HW min.	HW max.	I	K	L	L1	L2	M	M1	N	O	P	α	α^*
2	6	52	20	5,5	25	11	38	154	11,5	19,5	12	6,0	12,5	78	89	28,5-32	30-31	37,5	5	32	105°	60°
3	8	79	20	7,5	37	19	48	200	10,0	18,5	18	7,5	-	111	114	41,0	-	48,0	6	40	105°	60°
4	10	101	32	8,6	54	16	65	244	16,5	45,5	20	13,0	-	141	130	55,5	-	53,0	8	53	105°	60°

* The opening angle can be changed by pressing in a stop pin.

Subject to technical alterations.

No. 6803S

Vertical toggle clamp with red handle and safety latch

for open and clamped positions.

With open clamping arm and angled base.

Galvanized and passivated. Stainless steel rivets, which run in hardened bushes. Bearings are pre-lubricated.

Ergonomic, oil-resistant handle with large grip surface and soft components. Safety clamping piece with finger protection. Lock washer for the thrust bolt at the end of the clamping arm.

Complete with tempered, galvanized clamping screw no. 6890.



Order no.	Size	F1 [kN]	F2 [kN]	Clamping screw	Weight [g]
90357	2	0,8	1,2	M6x35	250
90365	3	1,2	2,5	M8x45	535
90373	4	1,7	3,0	M8x65	750

No. 6803SY

Vertical toggle clamp with yellow handle and safety latch



Order no.	Size	F1 [kN]	F2 [kN]	Clamping screw	Weight [g]
557202	2	0,8	1,2	M6x35	250
557203	3	1,2	2,5	M8x45	535
557204	4	1,7	3,0	M8x65	750

No. 6803SJ

Vertical toggle clamp with orange handle and safety latch



Order no.	Size	F1 [kN]	F2 [kN]	Clamping screw	Weight [g]
557423	2	0,8	1,2	M6x35	250
557424	3	1,2	2,5	M8x45	535
557425	4	1,7	3,0	M8x65	750

No. 6803SE

Vertical toggle clamp with blue handle and safety latch



Order no.	Size	F1 [kN]	F2 [kN]	Clamping screw	Weight [g]
557738	2	0,8	1,2	M6x35	250
557739	3	1,2	2,5	M8x45	535
557740	4	1,7	3,0	M8x65	750

Subject to technical alterations.

No. 6803SG

Vertical toggle clamp with green handle and safety latch



Order no.	Size	F1 [kN]	F2 [kN]	Clamping screw	Weight [g]
557575	2	0,8	1,2	M6x35	250
557576	3	1,2	2,5	M8x45	535
557577	4	1,7	3,0	M8x65	750

No. 6803ST

Vertical toggle clamp with black handle and safety latch



Order no.	Size	F1 [kN]	F2 [kN]	Clamping screw	Weight [g]
558149	2	0,8	1,2	M6x35	250
558150	3	1,2	2,5	M8x45	535
558151	4	1,7	3,0	M8x65	750

Recommendations



No. 6896,
page 171



No. 6803,
page 18



No. 6821A,
page 139

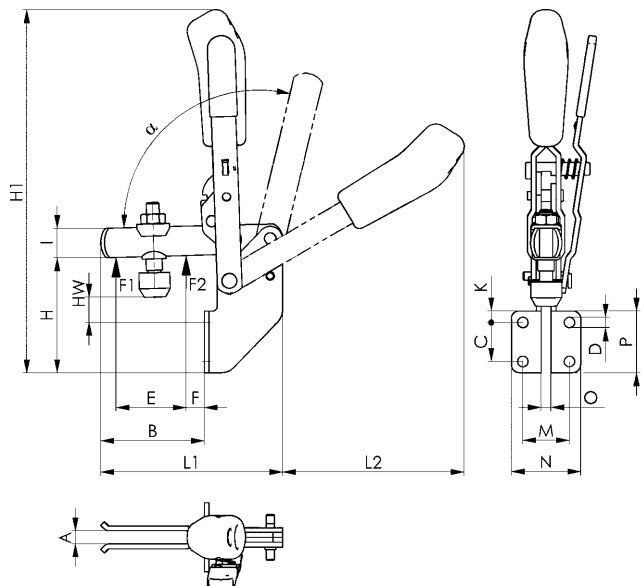

CAD

Dimensions:

Size	A	B	C	D	E	F	H	H1	HW min.	HW max.	I	K	L1	L2	M	N	O	P	α	α*
2	6	41	20	6,1	25	6	60,0	176,5	8	15,5	12	6	77	90	25,5	37,0	5	32	105°	60°
3	8	62	24	6,5	37	11	71,0	223,0	9	17,5	18	7	110	112	28,5	42,5	6	38	105°	60°
4	10	83	32	8,5	54	11	101,5	280,0	11	39,5	20	54	141	129	32,0	52,0	8	96	105°	60°

* The opening angle can be changed by pressing in a stop pin.

Subject to technical alterations.

No. 6804S

Vertical toggle clamp with red handle and safety latch

for open and clamped positions.

With solid clamping arm and horizontal base.

Galvanized and passivated. Stainless steel rivets, which run in hardened bushes. Bearings are pre-lubricated.

Ergonomic, oil-resistant handle with large grip surface and soft components. Safety clamping piece with finger protection.

Complete with tempered, galvanized clamping screw no. 6890 and sleeve to weld on.



Order no.	Size	F1 [kN]	F2 [kN]	Clamping screw	Weight [g]
90399	3	1,4	2,5	M8x45	470
90407	4	2,0	3,0	M8x65	690

No. 6804SY

Vertical toggle clamp with yellow handle and safety latch



Order no.	Size	F1 [kN]	F2 [kN]	Clamping screw	Weight [g]
557205	3	1,4	2,5	M8x45	470

No. 6804SJ

Vertical toggle clamp with orange handle and safety latch



Order no.	Size	F1 [kN]	F2 [kN]	Clamping screw	Weight [g]
557426	3	1,4	2,5	M8x45	470

No. 6804SE

Vertical toggle clamp with blue handle and safety latch



Order no.	Size	F1 [kN]	F2 [kN]	Clamping screw	Weight [g]
557746	3	1,4	2,5	M8x45	470

Subject to technical alterations.

No. 6804SG

Vertical toggle clamp with green handle and safety latch



Order no.	Size	F1 [kN]	F2 [kN]	Clamping screw	Weight [g]
557578	3	1,4	2,5	M8x45	470

No. 6804ST

Vertical toggle clamp with black handle and safety latch



Order no.	Size	F1 [kN]	F2 [kN]	Clamping screw	Weight [g]
558155	3	1,4	2,5	M8x45	470

Recommendations



No. 6886,
page 168



No. 6804,
page 20



No. 6834S,
page 78

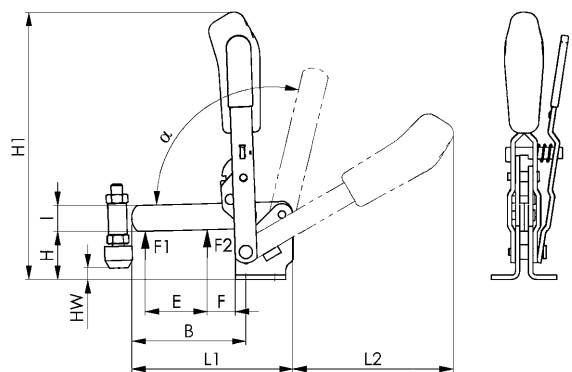
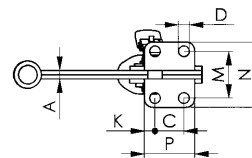

Dimensions:

Size	A	B	C	D	E	F	H	H1	HW min.	HW max.	I	K	L1	L2	M	N	P	α	α^*
3	6	81	20	7,1	43	19	48,0	186	0	12	18	7,5	112	112	32	46	35	105°	60°
4	8	101	32	8,5	61	16	42,5	220	-8	21	20	13,0	140	130	45	64	53	105°	60°

* The opening angle can be changed by pressing in a stop pin.

Subject to technical alterations.

No. 6830S

Horizontal toggle clamp with red handle and safety latch

for open and clamped positions.

With open clamping arm and horizontal base.

Galvanized and passivated. Stainless steel rivets which run in hardened bushes, bearings are lubricated.

Ergonomic, oil-resistant handle with large grip surface and soft components. Lock washer for the thrust bolt at the end of the clamping arm.

Complete with tempered, galvanized clamping screw no. 6890.



Order no.	Size	F1 [kN]	F2 [kN]	Clamping screw	Weight [g]
92650	3	1,8	2,5	M8x45	390
93112	4	2,0	3,0	M8x65	800

Note:

For suitable sensor monitor for size 3 see no. 6897S.

No. 6830SY

Horizontal toggle clamp with yellow handle and safety latch



Order no.	Size	F1 [kN]	F2 [kN]	Clamping screw	Weight [g]
557206	3	1,8	2,5	M8x45	390
557207	4	2,0	3,0	M8x65	800

No. 6830SJ

Horizontal toggle clamp with orange handle and safety latch



Order no.	Size	F1 [kN]	F2 [kN]	Clamping screw	Weight [g]
557427	3	1,8	2,5	M8x45	390
557428	4	2,0	3,0	M8x65	800

No. 6830SE

Horizontal toggle clamp with blue handle and safety latch



Order no.	Size	F1 [kN]	F2 [kN]	Clamping screw	Weight [g]
557747	3	1,8	2,5	M8x45	390
557748	4	2,0	3,0	M8x65	800

No. 6830SG

Horizontal toggle clamp with green handle and safety latch



Order no.	Size	F1 [kN]	F2 [kN]	Clamping screw	Weight [g]
557579	3	1,8	2,5	M8x45	390
557580	4	2,0	3,0	M8x65	800

No. 6830ST

Horizontal toggle clamp with black handle and safety latch



Order no.	Size	F1 [kN]	F2 [kN]	Clamping screw	Weight [g]
558156	3	1,8	2,5	M8x45	390
558157	4	2,0	3,0	M8x65	800

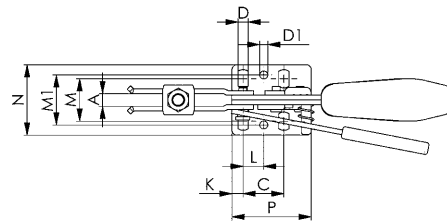
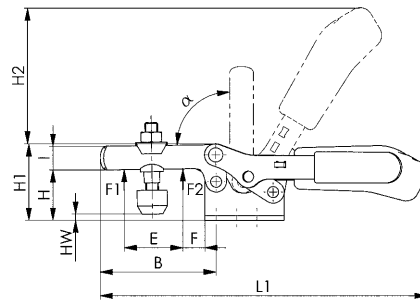

Recommendations



No. 6895,
page 178



No. 6830,
page 32



No. 6834S,
page 78

Dimensions:

Size	A	B	C	D	D1	E	F	H	H1	H2	HW min.	HW max.	I	K	L	L1	M	M1	N	P	α
3	8	73	25,7	6,5	5,1	38	14	32	48,5	86,0	-2	9	15	7	13,0	206	22,0-31,8	31,6	45,5	50	90°
4	10	113	41,0	8,5	8,5	63	27	45	75,0	126,5	-4	24	20	8	20,5	287	29,0-43,0	43,0	58	57	90°

Subject to technical alterations.

No. 6832S

Horizontal toggle clamp with red handle and safety latch

for open and clamped positions.

With open clamping arm and vertical base.

Galvanized and passivated. Stainless steel rivets, which run in hardened bushes. Bearings are pre-lubricated.

Ergonomic, oil-resistant handle with large grip surface and soft components. Lock washer for the thrust bolt at the end of the clamping arm.

Complete with tempered, galvanized clamping screw no. 6890.



Order no.	Size	F1 [kN]	F2 [kN]	Clamping screw	Weight [g]
93195	3	1,8	2,5	M8x45	390
93260	4	2,0	3,0	M8x65	800

No. 6832SY

Horizontal toggle clamp with yellow handle and safety latch



Order no.	Size	F1 [kN]	F2 [kN]	Clamping screw	Weight [g]
557209	3	1,8	2,5	M8x45	390
557210	4	2,0	3,0	M8x65	800

No. 6832SJ

Horizontal toggle clamp with orange handle and safety latch



Order no.	Size	F1 [kN]	F2 [kN]	Clamping screw	Weight [g]
557429	3	1,8	2,5	M8x45	390
557430	4	2,0	3,0	M8x65	800

No. 6832SE

Horizontal toggle clamp with blue handle and safety latch



Order no.	Size	F1 [kN]	F2 [kN]	Clamping screw	Weight [g]
557749	3	1,8	2,5	M8x45	390
557750	4	2,0	3,0	M8x65	800

No. 6832SG

Horizontal toggle clamp with green handle and safety latch



Order no.	Size	F1 [kN]	F2 [kN]	Clamping screw	Weight [g]
557581	3	1,8	2,5	M8x45	390
557582	4	2,0	3,0	M8x65	800

No. 6832ST

Horizontal toggle clamp with black handle and safety latch



Order no.	Size	F1 [kN]	F2 [kN]	Clamping screw	Weight [g]
558158	3	1,8	2,5	M8x45	390
558159	4	2,0	3,0	M8x65	800

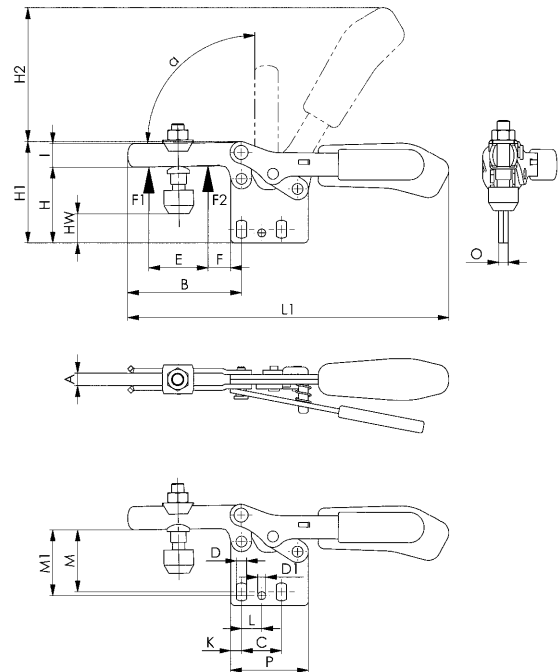

Recommendations



No. 6896,
page 171



No. 6890,
page 164



No. 6832,
page 36

Dimensions:

Size	A	B	C	D	D1	E	F	H	H1	H2	HW min.	HW max.	I	K	L	L1	M	M1	O	P	α
3	8	73	25,7	6,5	5,1	38	14	49,0	65	86	14,5	26	15	7	13,0	206	37,5-42,5	42	6	50	90°
4	10	113	41,0	8,5	8,5	63	27	66,5	97	126	17,5	46	20	8	20,5	287	52,0-59,0	59	8	57	90°

Subject to technical alterations.

No. 6834S

Horizontal toggle clamp with red handle and safety latch

for open and clamped positions.

With solid clamping arm and horizontal base.

Galvanized and passivated. Stainless steel rivets, which run in hardened bushes. Bearings are pre-lubricated.

Ergonomic, oil-resistant handle with large grip surface and soft components.

Complete with tempered, galvanized clamping screw no. 6885 and sleeve to weld on.



Order no.	Size	F1 [kN]	F2 [kN]	Clamping screw	Weight [g]
93534	4	2	3	M8x65	800

No. 6834SY

Horizontal toggle clamp with yellow handle and safety latch



Order no.	Size	F1 [kN]	F2 [kN]	Clamping screw	Weight [g]
557211	4	2	3	M8x65	800

No. 6834SJ

Horizontal toggle clamp with orange handle and safety latch



Order no.	Size	F1 [kN]	F2 [kN]	Clamping screw	Weight [g]
557431	4	2	3	M8x65	800

No. 6834SE

Horizontal toggle clamp with blue handle and safety latch



Order no.	Size	F1 [kN]	F2 [kN]	Clamping screw	Weight [g]
557751	4	2	3	M8x65	800

Subject to technical alterations.

No. 6834SG

Horizontal toggle clamp with green handle and safety latch

Order no.	Size	F1 [kN]	F2 [kN]	Clamping screw	Weight [g]
557583	4	2	3	M8x65	800



No. 6834ST

Horizontal toggle clamp with black handle and safety latch

Order no.	Size	F1 [kN]	F2 [kN]	Clamping screw	Weight [g]
558160	4	2	3	M8x65	800

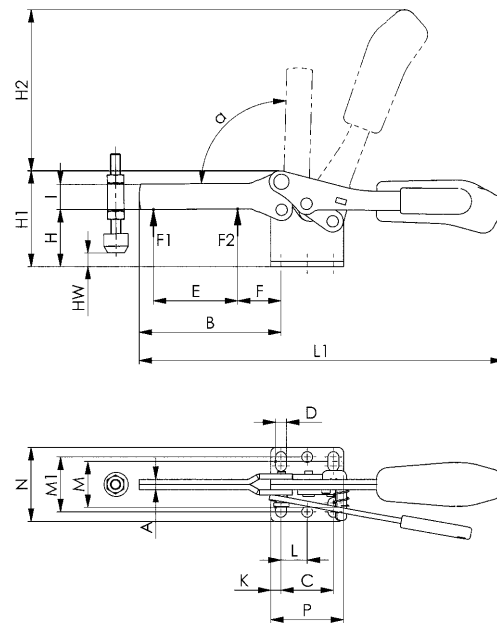

CAD

Recommendations



No. 6886,
page 168



No. 6834,
page 40



No. 6804S,
page 72

Dimensions:

Size	A	B	C	D	E	F	H	H1	H2	HW min.	HW max.	I	K	L	L1	M	M1	N	P	α
4	8	111	41	8,5	66	34	45	75	126,5	-6	23	20	8	20,5	286	29 - 43	43	58	57	90°

Subject to technical alterations.

No. 6840S

Push-pull type toggle clamp with safety latch

For open and clamped positions.

Without angle base. Push and pull-clamping (equal operation of rod and lever).

Long rod-guide with attaching thread and nut. Rivets made of stainless steel, lever-parts and rod of tempered steel.

Bearings are pre-lubricated.

Ergonomic, oil-resistant handle with large grip surface and soft components.

Complete with tempered, galvanized clamping screw no. 6880.



Order no.	Size	F1 [kN]	F2 [kN]	Clamping screw	Weight [g]
92619	3	2,5	2,5	M8x35	402

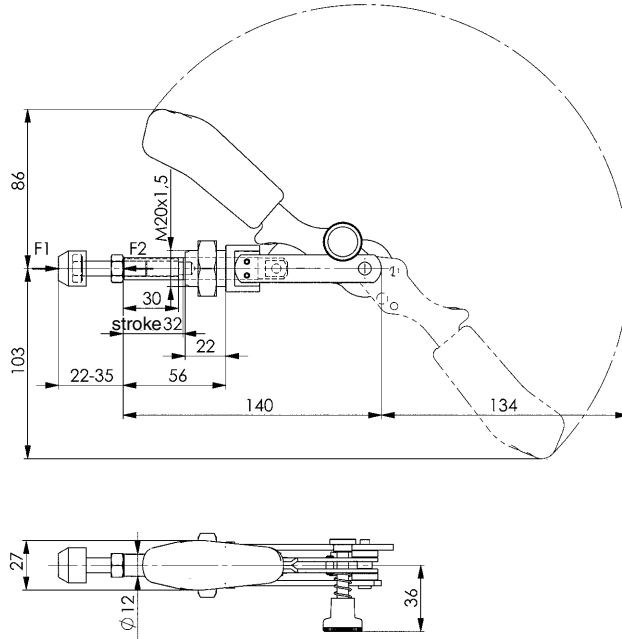

Recommendations



No. 6843,
page 52



No. 6844,
page 50



No. 6800S,
page 66

Subject to technical alterations.

No. 6847S

Hook type toggle clamp with safety latch

Lock when closed.

Galvanized and passivated. Case-hardened, pre-lubricated bearing bushes. Rivet is stainless steel. Hook and clamping sleeve tempered. Handle made of red, oil-resistant plastic.



CAD

Order no.	Size	F1 [kN]	Weight [g]
93666	3	3	295

Note:

The engagement height of 23 mm must be observed to ensure secure latching.

On request:

A „stainless steel“ version is available.

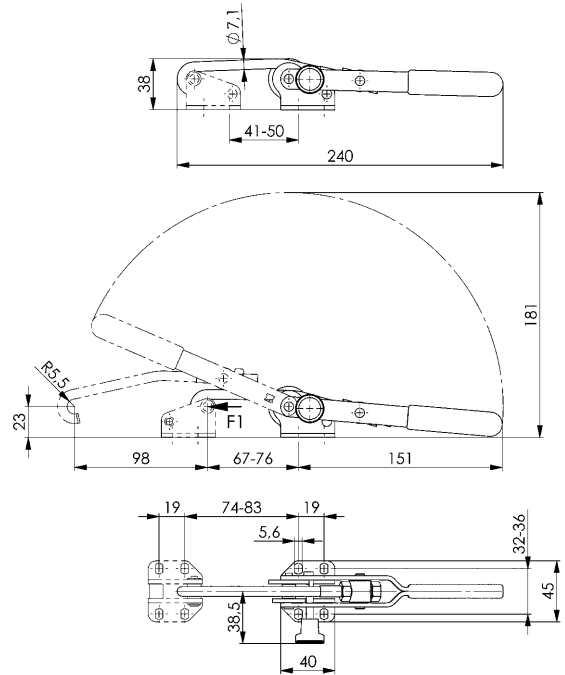

Recommendations



No. 6847G,
page 58



No. 6847,
page 58



No. 6847SU,
page 81

No. 6847SU

Hook type toggle clamp with safety latch

U-shackle, locks when closed.

Galvanized and passivated. Case-hardened, pre-lubricated bearing bushes. Stainless steel rivets. Tempered shackle and clamping sleeve. Handle made of red, oil-resistant plastic.

Supplied complete with counter catch.



CAD

Order no.	Size	F1 [kN]	Weight [g]
91470	3	3	295

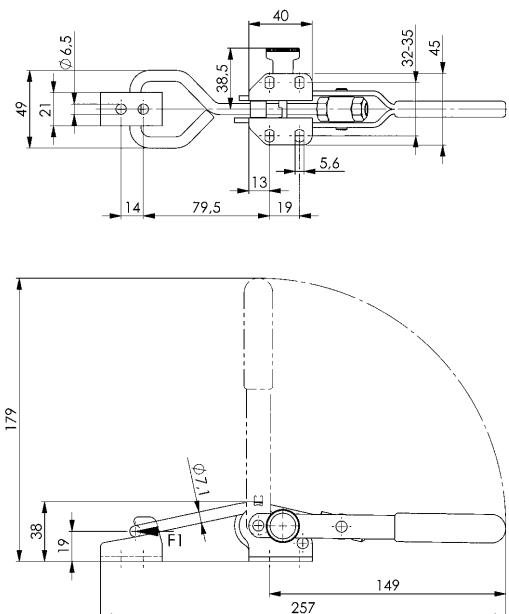

Recommendations



No. 6848H,
page 60



No. 6848V,
page 62



No. 6849PH,
page 64

No. 6848HS

Horizontal hook-type toggle clamp with red handle and safety latch

Galvanized and passivated. Stainless steel rivets, which run in hardened bushes. Tempered hook. Bearings are pre-lubricated. Ergonomic, oil-resistant handle with large grip surface and soft components.

Supplied complete with counter catch.



Order no.	Size	F1	Weight
		[kN]	[g]
92692	4	7,0	850

Also available in „STAINLESS STEEL“ version (no. 6848HSNI).

No. 6848SY

Horizontal hook-type toggle clamp with yellow handle and safety latch



Order no.	Size	F1	Weight
		[kN]	[g]
557212	4	7,0	850

Also available in „STAINLESS STEEL“ version (no. 6848HSNIY).

No. 6848HSJ

Horizontal hook-type toggle clamp with orange handle and safety latch



Order no.	Size	F1	Weight
		[kN]	[g]
557432	4	7,0	850

Also available in „STAINLESS STEEL“ version (no. 6848HSNIJ).

No. 6848HSE

Horizontal hook-type toggle clamp with blue handle and safety latch

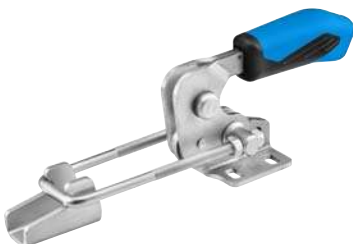

Order no.	Size	F1	Weight
		[kN]	[g]
557752	4	7,0	850

Also available in „STAINLESS STEEL“ version (no. 6848HSNIE).

No. 6848HSG

Horizontal hook-type toggle clamp with green handle and safety latch

Order no.	Size	F1 [kN]	Weight [g]
557584	4	7,0	850

Also available in „STAINLESS STEEL“ version (no. 6848HSNIG).



No. 6848HST

Horizontal hook-type toggle clamp with black handle and safety latch

Order no.	Size	F1 [kN]	Weight [g]
558161	4	7,0	850

Also available in „STAINLESS STEEL“ version (no. 6848HSNIT).

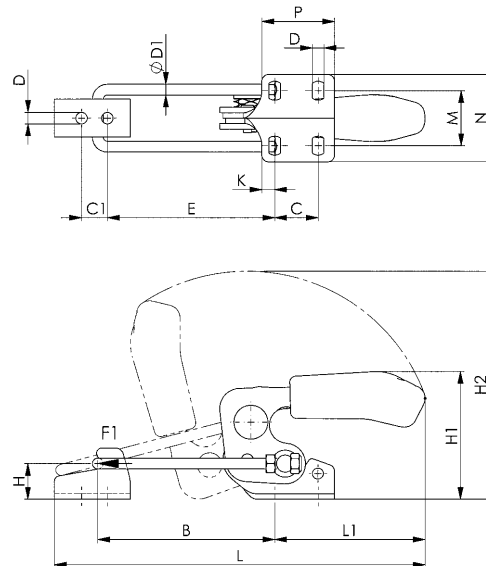

CAD

Recommendations



No. 6847SU,
page 81



No. 6847S,
page 81



No. 6848GH,
page 179

Dimensions:

Size	B min.	B max.	C	C1	D	dia. D1	E min.	E max.	H	H1	H2	K	L min.	L max.	L1	M	N	P
4	66	130	32	19	8,5	8	59	123	26	94	168	9,5	209	273	111	35-46	64,5	53,5

Subject to technical alterations.

Toggle clamp made from 1.4301 / V2A or 1.4567 for special-purpose applications - in the chemical and food industries for example. Especially well suited to applications on machines and devices that are subject to hygiene regulations or are used outdoors under unfavourable weather conditions or in corrosive environments.

THE ADVANTAGES OF STAINLESS STEEL:

Primary positive properties of the material are its resistance to corrosion due to humidity, water or other external influences and its resistance to acids. In addition, the material exhibits antimagnetic properties. Additional finishing work such as painting or galvanizing, either before or after installation or use, is generally not required. This saves time and eliminates additional costs.



**INOX
STAINLESS STEEL**

No. 6800NI

Vertical toggle clamp with red handle with open clamping arm and horizontal base.

Stainless steel, polished. In sizes 2 to 4, rivets run in bearing bushes. Bearings are pre-lubricated. Ergonomic, oil-resistant handle with large grip surface and soft components.

Supplied complete with stainless clamping screw no. 6890NI.

Also suitable for use in the food industry.

Order no.	Size	F1 [kN]	F2 [kN]	Clamping screw	Weight [g]
95000	0	0,5	0,7	M4x25	60
95026	1	0,6	1,1	M5x30	105
95042	2	0,8	1,2	M6x35	175
95067	3	1,2	2,5	M8x45	410
95083	4	1,7	3,0	M8x65	630



No. 6800NIY

Vertical toggle clamp with yellow handle



Order no.	Size	F1 [kN]	F2 [kN]	Clamping screw	Weight [g]
557213	0	0,5	0,7	M4x25	60
557214	1	0,6	1,1	M5x30	105
557215	2	0,8	1,2	M6x35	175
557216	3	1,2	2,5	M8x45	410
557217	4	1,7	3,0	M8x65	630

No. 6800NIJ

Vertical toggle clamp with orange handle



Order no.	Size	F1 [kN]	F2 [kN]	Clamping screw	Weight [g]
557433	0	0,5	0,7	M4x25	60
557434	1	0,6	1,1	M5x30	105
557435	2	0,8	1,2	M6x35	175
557436	3	1,2	2,5	M8x45	410
557437	4	1,7	3,0	M8x65	630

Subject to technical alterations.

No. 6800NIE

Vertical toggle clamp with blue handle



Order no.	Size	F1 [kN]	F2 [kN]	Clamping screw	Weight [g]
557753	0	0,5	0,7	M4x25	60
557754	1	0,6	1,1	M5x30	105
557755	2	0,8	1,2	M6x35	175
557756	3	1,2	2,5	M8x45	410
557757	4	1,7	3,0	M8x65	630

No. 6800NIG

Vertical toggle clamp with green handle



Order no.	Size	F1 [kN]	F2 [kN]	Clamping screw	Weight [g]
557586	0	0,5	0,7	M4x25	60
557587	1	0,6	1,1	M5x30	105
557588	2	0,8	1,2	M6x35	175
557589	3	1,2	2,5	M8x45	410
557590	4	1,7	3,0	M8x65	630

No. 6800NIT

Vertical toggle clamp with black handle



Order no.	Size	F1 [kN]	F2 [kN]	Clamping screw	Weight [g]
558164	0	0,5	0,7	M4x25	60
558165	1	0,6	1,1	M5x30	105
558166	2	0,8	1,2	M6x35	175
558167	3	1,2	2,5	M8x45	410
558168	4	1,7	3,0	M8x65	630

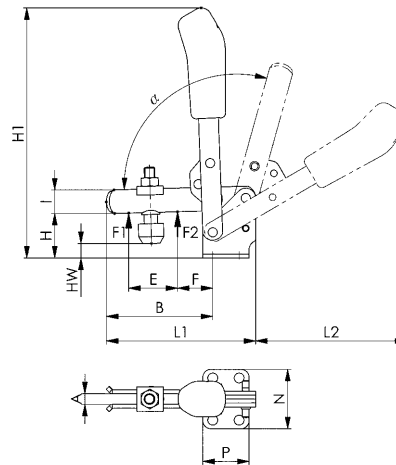

Recommendations



No. 6830NI, page 88



No. 6841NI, page 92



No. 6890NI, page 164

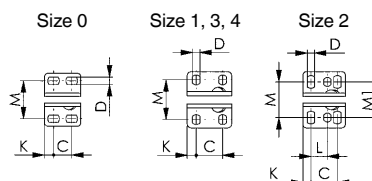

Dimensions:

Size	A	B	C	D	E	F	H	H1	HW min.	HW max.	I	K	L	L1	L2	M	M1	N	P	α	α*
0	4	31	8,5-13,5	4,5	14,0	5,5	18,0	81	-1,5	3,5	8	5,5	-	49	50	23	-	32	22	95°	-
1	5	39	16,0	4,5	18,0	6,0	19,0	98	-4,0	2,0	10	5,5	-	61	58	22-26	-	34	27	95°	-
2	6	52	20,0	5,5	25,0	11,0	23,0	129	-3,3	4,5	12	6,0	12,5	78	80	23-31	27	43	32	105°	60°
3	8	79	20,0	7,5	37,0	19,0	33,0	186	3,0	10,5	18	7,5	-	112	112	32	-	46	35	105°	60°
4	10	101	32,0	8,6	54,0	16,0	42,5	221	-6,0	19,5	20	13,0	-	141	130	45	-	64	53	105°	60°

* The opening angle can be changed by pressing in a stop pin.

Subject to technical alterations.

No. 6803NI

Vertical toggle clamp with red handle

with open clamping arm and angle base.

Stainless steel, polished. Rivets running in greased bushes. Ergonomic, oil-resistant handle with large grip surface and soft components.

Supplied complete with stainless clamping screw no. 6890NI.

Also suitable for use in the food industry.

Order no.	Size	F1 [kN]	F2 [kN]	Clamping screw	Weight [g]
95133	2	0,8	1,2	M6x35	220



No. 6803NIY

Vertical toggle clamp with yellow handle



Order no.	Size	F1 [kN]	F2 [kN]	Clamping screw	Weight [g]
557273	2	0,8	1,2	M6x35	220

No. 6803NIJ

Vertical toggle clamp with orange handle



Order no.	Size	F1 [kN]	F2 [kN]	Clamping screw	Weight [g]
557438	2	0,8	1,2	M6x35	220

No. 6803NIE

Vertical toggle clamp with blue handle



Order no.	Size	F1 [kN]	F2 [kN]	Clamping screw	Weight [g]
557759	2	0,8	1,2	M6x35	220

Subject to technical alterations.

No. 6803NIG

Vertical toggle clamp with green handle



Order no.	Size	F1 [kN]	F2 [kN]	Clamping screw	Weight [g]
557595	2	0,8	1,2	M6x35	220

No. 6803NIT

Vertical toggle clamp with black handle



Order no.	Size	F1 [kN]	F2 [kN]	Clamping screw	Weight [g]
558169	2	0,8	1,2	M6x35	220

Recommendations



No. 6800NI,
page 84



No. 6841NI,
page 92



No. 6890NI,
page 164

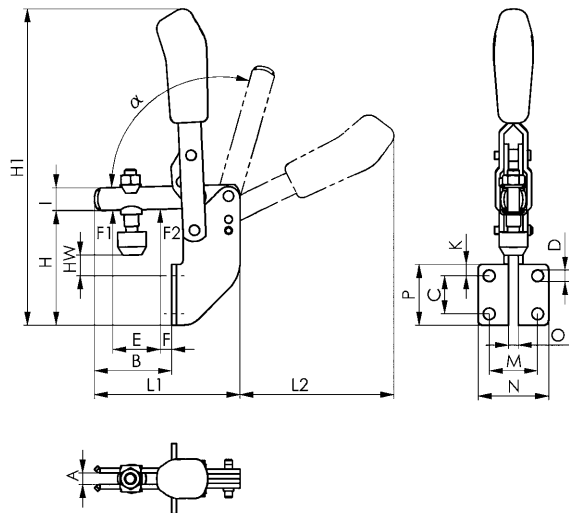

CAD

Dimensions:

Size	A	B	C	D	E	F	H	H1	HW min.	HW max.	I	K	L1	L2	M	N	O	P	α	α^*
2	6	41	20	6,1	25	6	60	167	8	15	12	6	77	81	25,5	37	5	32	105°	60°

* The opening angle can be changed by pressing in a stop pin.

Subject to technical alterations.

No. 6830NI

Horizontal toggle clamp with red handle

with open clamping arm and horizontal base.

Stainless steel, polished. In sizes 2 to 5, rivets run in bearing bushes. Bearings are pre-lubricated.

Ergonomic, oil-resistant handle with large grip surface and soft components.

Supplied complete with stainless clamping screw no. 6890NI.

Also suitable for use in the food industry.



Order no.	Size	F1 [kN]	F2 [kN]	Clamping screw	Weight [g]
95141	0	0,25	0,4	M4x25	35
95166	1	0,80	1,1	M5x30	105
95182	2	1,00	1,2	M6x35	185
95208	3	1,80	2,5	M8x45	320
95224	4	2,00	3,0	M8x65	700

Note:

For suitable sensor monitor for size 3 see no. 6897S.

No. 6830NIY

Horizontal toggle clamp with yellow handle



Order no.	Size	F1 [kN]	F2 [kN]	Clamping screw	Weight [g]
557274	0	0,25	0,4	M4x25	35
557275	1	0,80	1,1	M5x30	105
557276	2	1,00	1,2	M6x35	185
557277	3	1,80	2,5	M8x45	320
557278	4	2,00	3,0	M8x65	700

No. 6830NIJ

Horizontal toggle clamp with orange handle



Order no.	Size	F1 [kN]	F2 [kN]	Clamping screw	Weight [g]
557439	0	0,25	0,4	M4x25	35
557440	1	0,80	1,1	M5x30	105
557441	2	1,00	1,2	M6x35	185
557442	3	1,80	2,5	M8x45	320
557443	4	2,00	3,0	M8x65	700

No. 6830NIE

Horizontal toggle clamp with blue handle



Order no.	Size	F1 [kN]	F2 [kN]	Clamping screw	Weight [g]
557760	0	0,25	0,4	M4x25	35
557761	1	0,80	1,1	M5x30	105
557762	2	1,00	1,2	M6x35	185
557763	3	1,80	2,5	M8x45	320
557764	4	2,00	3,0	M8x65	700

Subject to technical alterations.

No. 6830NIG

Horizontal toggle clamp with green handle



Order no.	Size	F1 [kN]	F2 [kN]	Clamping screw	Weight [g]
557596	0	0,25	0,4	M4x25	35
557597	1	0,80	1,1	M5x30	105
557598	2	1,00	1,2	M6x35	185
557599	3	1,80	2,5	M8x45	320
557600	4	2,00	3,0	M8x65	700

No. 6830NIT

Horizontal toggle clamp with black handle



Order no.	Size	F1 [kN]	F2 [kN]	Clamping screw	Weight [g]
558170	0	0,25	0,4	M4x25	35
558171	1	0,80	1,1	M5x30	105
558172	2	1,00	1,2	M6x35	185
558173	3	1,80	2,5	M8x45	320
558174	4	2,00	3,0	M8x65	700

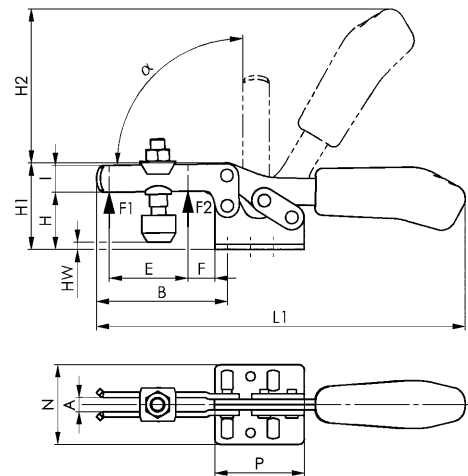

Recommendations



No. 6800NI,
page 84



No. 68300NI,
page 90



No. 6890NI,
page 164

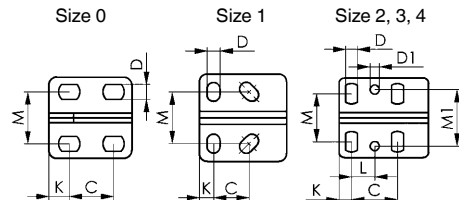

Dimensions:

Size	A	B	C	D	D1	E	F	H	H1	H2	HW min.	HW max.	I	K	L	L1	M	M1	N	P	α
0	4	28	11,5-15,5	4,6	-	9,0	5	14,5	23,0	34	-5,0	0,6	7,5	6,25	-	79	16,0	-	25,0	25,5	90°
1	5	42	13,3-14,7	5,2	-	18,6	8	19,0	30,0	49	-4,0	2,0	10,0	5,50	-	120	18,0-21,5	-	34,0	34,0	90°
2	6	64	26,0	5,6	5,6	32,0	16	24,0	45,0	68	-1,6	5,0	13,0	6,00	12,7	162	19,5-29,5	28,5	42,0	38,0	90°
3	8	73	25,7	6,5	5,1	36,0	14	32,0	48,5	86	-2,0	9,0	15,0	7,00	13,0	206	22,0-31,8	31,6	44,5	50,0	90°
4	10	113	41,0	8,5	8,5	63,0	27	45,0	75,0	126	-4,0	24,0	20,0	8,00	20,5	287	29,0-43,0	43,0	58,0	57,0	90°

Subject to technical alterations.

No. 68300NI

Horizontal toggle clamp plus with red handle

with increased retaining forces, open clamp arm and horizontal base. Stainless steel, polished. Bearings positioned are lubricated. Ergonomic, oil-resistant handle with large grip surface and soft components. Safety clamping piece with retainer for the clamping screw at the end of the clamping arm. Supplied complete with stainless clamping screw no. 68301NI. Also suitable for use in the food industry.

Order no.	Size	F1 [kN]	F2 [kN]	Clamping screw	Weight [g]
560013	1	1,1	1,7	M5 x 35	150
555175	2	1,6	3,0	M6 x 50	450
558985	3	2,5	4,0	M8 x 58	600
555176	4	3,5	8,0	M10 x 76	1250



No. 68300NIY

Horizontal toggle clamp plus with yellow handle



Order no.	Size	F1 [kN]	F2 [kN]	Clamping screw	Weight [g]
560157	1	1,1	1,7	M5 x 35	150
557279	2	1,6	3,0	M6 x 50	450
560158	3	2,5	4,0	M8 x 58	600
557280	4	3,5	8,0	M10 x 76	1250

No. 68300NIJ

Horizontal toggle clamp plus with orange handle



Order no.	Size	F1 [kN]	F2 [kN]	Clamping screw	Weight [g]
560163	1	1,1	1,7	M5 x 35	150
557444	2	1,6	3,0	M6 x 50	450
560164	3	2,5	4,0	M8 x 58	600
557445	4	3,5	8,0	M10 x 76	1250

No. 68300NIE

Horizontal toggle clamp plus with blue handle



Order no.	Size	F1 [kN]	F2 [kN]	Clamping screw	Weight [g]
560159	1	1,1	1,7	M5 x 35	150
557765	2	1,6	3,0	M6 x 50	450
560160	3	2,5	4,0	M8 x 58	600
557766	4	3,5	8,0	M10 x 76	1250

No. 68300NIG

Horizontal toggle clamp plus with green handle



Order no.	Size	F1 [kN]	F2 [kN]	Clamping screw	Weight [g]
560161	1	1,1	1,7	M5 x 35	150
557601	2	1,6	3,0	M6 x 50	450
560162	3	2,5	4,0	M8 x 58	600
557602	4	3,5	8,0	M10 x 76	1250

No. 68300NIT

Horizontal toggle clamp plus with black handle



Order no.	Size	F1 [kN]	F2 [kN]	Clamping screw	Weight [g]
560165	1	1,1	1,7	M5 x 35	150
558175	2	1,6	3,0	M6 x 50	450
560166	3	2,5	4,0	M8 x 58	600
558176	4	3,5	8,0	M10 x 76	1250



CAD

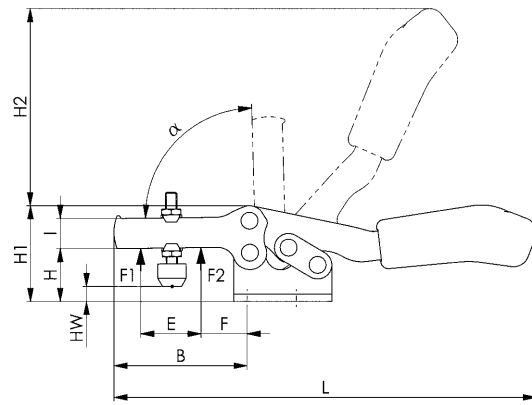

Recommendations



No. 68301NI,
page 165



No. 6800NI,
page 84

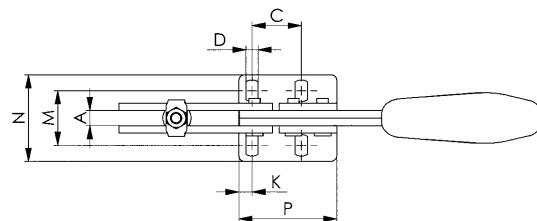

Dimensions:

Size	A	B	C	D	E	F	H	H1	H2	HW min.	HW max.	I	K	L	M	N	P	α
1	5	44	13,5	4,3	20,5	15,0	19,6	37	52	1	10,2	12	6,0	125	14,7 - 19,5	27,2	40	80°
2	8	71	26,0	6,5	39,0	14,0	28,0	51	110	-1	12,0	16	7,0	224	23,5 - 34,0	46,0	52	90°
3	8	74	26,2	6,5	41,5	20,6	35,0	61	112	1	13,0	18	6,5	243	27,5 - 38,0	49,2	56	90°
4	10	120	41,5	8,6	69,0	23,0	41,0	77	135	-2	17,5	24	10,5	329	34,5 - 45,0	60,0	76	90°

Subject to technical alterations.

No. 6841NI

Push-pull type toggle clamp with red handle

with small angle base. For push- and pull-clamping. (Equal operation of rod and lever). Stainless steel, polished. Long rod-guide with attaching thread and nut. Bush for size 3. Bearings pre-lubricated. Lever can be set to any angle relative to base. Ergonomic, oil-resistant handle with large grip surface and soft components.

Supplied complete with stainless clamping screw no. 6880NI.

Also suitable for use in the food industry.



Order no.	Size	F1 [kN]	F2 [kN]	Clamping screw	Weight [g]
95265	0	0,8	0,8	M4x20	65
95299	3	2,5	2,5	M8x35	445

No. 6841NIY

Push-pull type toggle clamp with yellow handle



Order no.	Size	F1 [kN]	F2 [kN]	Clamping screw	Weight [g]
557288	0	0,8	0,8	M4x20	65

No. 6841NIJ

Push-pull type toggle clamp with orange handle



Order no.	Size	F1 [kN]	F2 [kN]	Clamping screw	Weight [g]
557453	0	0,8	0,8	M4x20	65

No. 6841NIE

Push-pull type toggle clamp with blue handle



Order no.	Size	F1 [kN]	F2 [kN]	Clamping screw	Weight [g]
557774	0	0,8	0,8	M4x20	65

Subject to technical alterations.

No. 6841NIG

Push-pull type toggle clamp with green handle



Order no.	Size	F1 [kN]	F2 [kN]	Clamping screw	Weight [g]
557610	0	0,8	0,8	M4x20	65

No. 6841NIT

Push-pull type toggle clamp with black handle



Order no.	Size	F1 [kN]	F2 [kN]	Clamping screw	Weight [g]
558185	0	0,8	0,8	M4x20	65



CAD

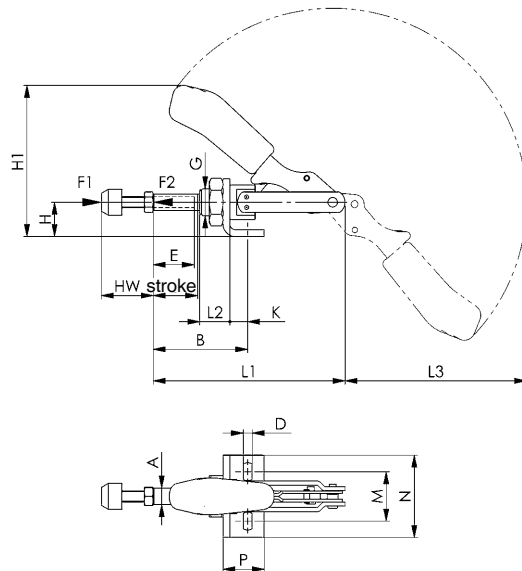

Recommendations



No. 6844NI,
page 94



No. 6800NI,
page 84



No. 6880NI,
page 167

Dimensions:

Size	A	B min.	B max.	D	E	G	H	H1	Stroke	HW min.	HW max.	K	L1	L2	L3	M	N	P
0	6,5	17	33	4,5	13	M10x1,0	12	49,3	16	12	20	6,5	66,5	10	54	16,0	25	16
3	12,0	37	69	6,5	30	M20x1,5	25	110,0	32	22	35	13,0	140,0	22	132	29,5-42,5	60	30

Subject to technical alterations.

No. 6844NI

Push-pull type toggle clamp with red handle

short version. For push and pull-clamping. Stainless steel, polished. Long rod-guide with attaching thread and nut. Shoulder screws pasted into thread. Bearings are pre-lubricated. Ergonomic, oil-resistant handle with large grip surface and soft components.

Supplied complete with stainless clamping screw no. 6880NI.

Also suitable for use in the food industry.



Order no.	Size	F1 [kN]	F2 [kN]	Clamping screw	Weight [g]
95349	2	1,0	1,0	M6x25	130
95364	3	2,5	2,5	M8x35	320
95380	5	4,0	4,0	M12x50	1200

Application:

Toggle for direct fit up in metal plates or fixtures, using its front attaching thread or by means of solid base angle no. 6843NI.

No. 6844NIY

Push-pull type toggle clamp with yellow handle



Order no.	Size	F1 [kN]	F2 [kN]	Clamping screw	Weight [g]
557289	2	1,0	1,0	M6x25	130
557290	3	2,5	2,5	M8x35	320
557291	5	4,0	4,0	M12x50	1200

No. 6844NIJ

Push-pull type toggle clamp with orange handle



Order no.	Size	F1 [kN]	F2 [kN]	Clamping screw	Weight [g]
557454	2	1,0	1,0	M6x25	130
557455	3	2,5	2,5	M8x35	320
557456	5	4,0	4,0	M12x50	1200

No. 6844NIE

Push-pull type toggle clamp with blue handle



Order no.	Size	F1 [kN]	F2 [kN]	Clamping screw	Weight [g]
557775	2	1,0	1,0	M6x25	130
557776	3	2,5	2,5	M8x35	320
557777	5	4,0	4,0	M12x50	1200

No. 6844NIG

Push-pull type toggle clamp with green handle



Order no.	Size	F1 [kN]	F2 [kN]	Clamping screw	Weight [g]
557611	2	1,0	1,0	M6x25	130
557612	3	2,5	2,5	M8x35	320
557613	5	4,0	4,0	M12x50	1200

No. 6844NIT

Push-pull type toggle clamp with black handle



Order no.	Size	F1 [kN]	F2 [kN]	Clamping screw	Weight [g]
558186	2	1,0	1,0	M6x25	130
558187	3	2,5	2,5	M8x35	320
558188	5	4,0	4,0	M12x50	1200

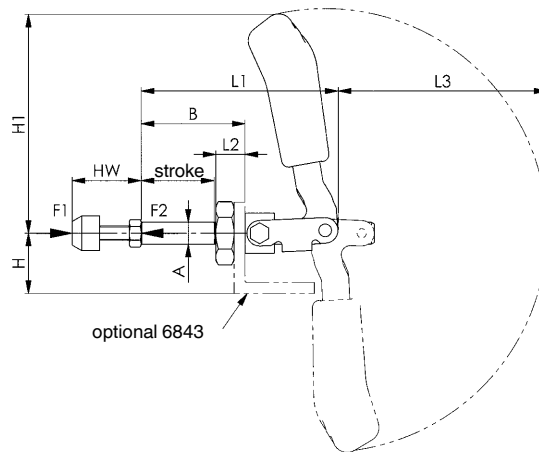

Recommendations



No. 6841NI, page 92



No. 6880NI, page 167

Dimensions:

Size	A	B	E	G	H	H1	Stroke	HW min.	HW max.	L1	L2	L3	N
2	10	36	15	M16x1,5	24	73,0	21,5	17	27,0	68,5	13	69	30,5
3	12	57	25	M20x1,5	33	120,5	40,0	22	37,5	108,0	16	115	33,0
5	16	92	45	M24x1,5	37	149,0	67,0	30	50,0	175,0	24	139	49,0

No. 6843NI

Angle base, solid

for no. 6841NI and no. 6844NI.
Stainless steel, polished. Increased range of application due to enlarged height of center line. Fastening by means of 4 screws.



Order no.	Size	C	D	D1	H	H1	K	M	N	P	T	Weight [g]
95091	0	16	4,5	10,2	13	23	9,0	15,5-20,5	30	30	3	35
95158	2	11-18	6,7	16,2	24	40	11,0	40	60	40	5	170
95174	3	19	6,7	20,2	33	50	14,5	41	65	44	6	260
95190	5	32	9,0	24,0	37	60	17,0	45	70	60	8	480

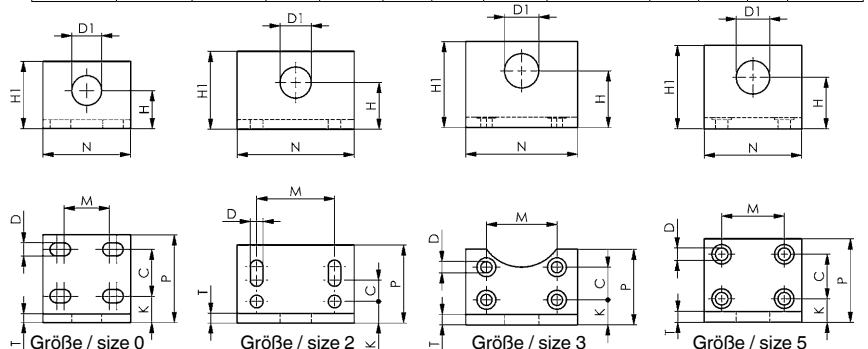

Subject to technical alterations.

No. 6847NI

Hook type toggle clamp

Stainless steel, polished. Rivets running in greased bushes. Handle of red high quality oil-resistant plastic. Ergonomic, oil-resistant handle with large grip surface and soft components for size 1. Suitable for use in food industry.



CAD

Order no.	Size	F1	Adjustm. distance	Weight
		[kN]	[mm]	
95406	1	1,0	8	100
95422	3	1,5	12	270
95448	5	2,5	14	850



INOX STAINLESS STEEL

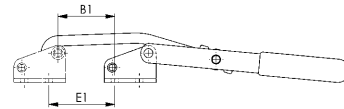
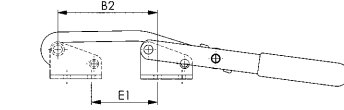
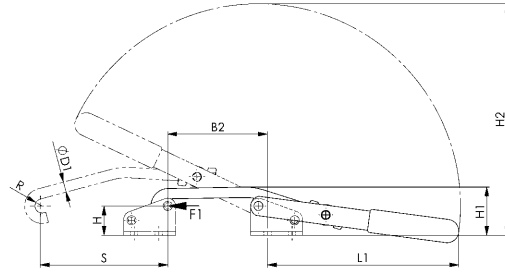
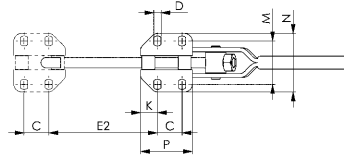

Recommendations



No. 6847GNI, page 96



No. 6847KNI, page 97



No. 6848HSNI, page 100

Dimensions:

Order no.	Size	B1	B2	C	D	dia. D1	E1	E2	H	H1	H2	K	L1	M	N	P	R	S
95406	1	16,0-23,0	35,0-42,0	19	4,5	6	16,5-23,5	35,0-42,5	22,7	35,0	111	6	88	25,5-30,5	40	31	4,5	45
95422	3	32,5-44,0	65,5-77,0	19	5,6	8	39,5-50,5	72,5-84,0	22,7	36,5	179	13	148	31,0-36,0	45	40	5,5	97
95448	5	26,5-40,0	57,0-71,0	29	11,2	12	27,5-42,0	59,5-73,0	49,1	70,5	280	13	228	56,0-63,5	85	55	8,0	146

No. 6847GNI

Counter catch

For hook type toggle clamp no. 6847NI. Stainless steel, polished.



CAD

Order no.	Size	Height	Length	Weight
		[mm]	[mm]	
95463	1	29	31	40
95489	3	29	40	70
95505	5	61	55	320



INOX STAINLESS STEEL

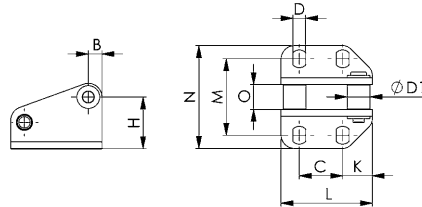

Dimensions:

Order no.	Size	B	C	D	dia. D1	H	K	L	M	N	O
95463	1	6	19	4,5	8	22,7	6	31	26,0-30,0	40	6,9
95489	3	6	19	5,6	10	22,7	13	40	31,3-35,8	45	10,9
95505	5	12	29	11,2	15	49,1	13	55	56,5-64,0	86	13,8

Subject to technical alterations.

No. 6847KNI

Hook type toggle clamp

for cylindrical mounting surfaces.
Stainless steel, polished. Rivets running in greased, continuous bearing bushes. Handle made of red, oil-resistant plastic. Use socket cap screws to ISO 4762 (DIN 912) for mounting.
Also suitable for use in the food industry.



CAD

Order no.	Size	F1 [kN]	Adjustm. distance [mm]	Weight [g]
95455	3	1,5	22	270

Note:

The range of movement can be adjusted by swiveling the base and repositioning the catch.

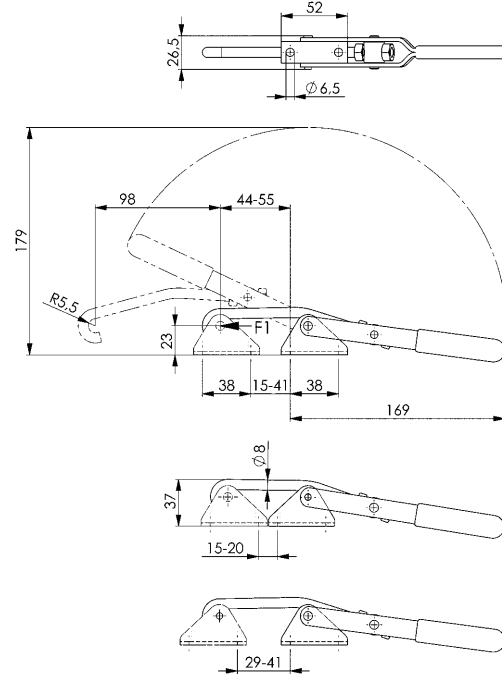

Recommendations



No. 6847GKNI, page 97



No. 6847NI, page 96



No. 6848HSNI, page 100

No. 6847GKNI

Counter catch

for cylindrical mounting surfaces.
For hook-type toggle clamp no. 6847KNI. Stainless steel, polished. Continuous bush. Use socket cap screws to ISO 4762 (DIN 912) for mounting.



CAD

Order no.	Size	Height [mm]	Length [mm]	Weight [g]
95596	3	32	52	65

Note:

The adjustment range of the clamp can be increased by turning the counter catch.

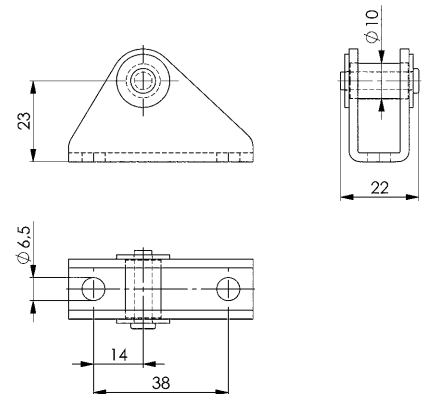

No. 6848HNI

Horizontal hook-type toggle clamp with red handle

Stainless steel, polished. Rivets running in greased bushes. Ergonomic, oil-resistant handle with large grip surface and soft components.

Supplied complete with counter catch.

Also suitable for use in the food industry.

Order no.	Size	F1	Weight
		[kN]	
95521	2	1,6	120
95547	3	3,2	330
95562	4	7,0	810



No. 6848HNIY

Horizontal hook-type toggle clamp with yellow handle



Order no.	Size	F1	Weight
		[kN]	
557281	2	1,6	120
557282	3	3,2	330
557283	4	7,0	810

No. 6848HNIJ

Horizontal hook-type toggle clamp with orange handle



Order no.	Size	F1	Weight
		[kN]	
557446	2	1,6	120
557447	3	3,2	330
557448	4	7,0	810

No. 6848HNIE

Horizontal hook-type toggle clamp with blue handle



Order no.	Size	F1	Weight
		[kN]	
557767	2	1,6	120
557768	3	3,2	330
557769	4	7,0	810

Subject to technical alterations.

No. 6848HNIG

Horizontal hook-type toggle clamp with green handle



Order no.	Size	F1 [kN]	Weight [g]
557603	2	1,6	120
557604	3	3,2	330
557605	4	7,0	810

No. 6848HNIT

Horizontal hook-type toggle clamp with black handle



Order no.	Size	F1 [kN]	Weight [g]
558178	2	1,6	120
558179	3	3,2	330
558180	4	7,0	810

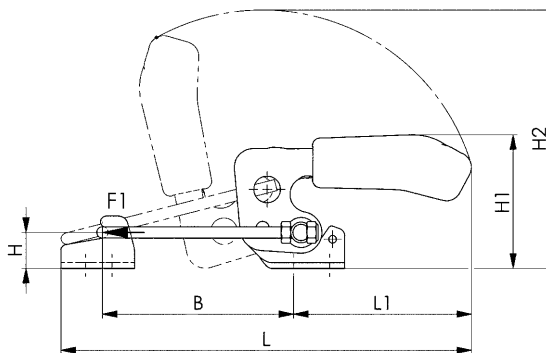
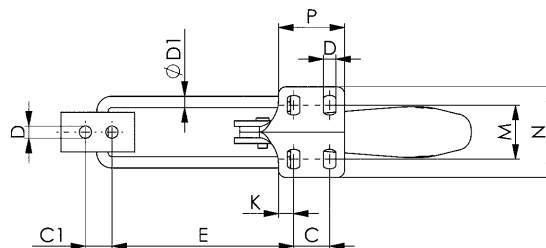

CAD

Recommendations



No. 6848GHNI, page 179



No. 6848HSNI, page 100



No. 6847NI, page 96

Dimensions:

Size	B min.	B max.	C	C1	D	dia. D1	E min.	E max.	H	H1	H2	K	L min.	L max.	L1	M	N	P
2	42,0	76	13	11	5,2	4	38,0	72	12	47,0	99	6,4	125	159	69	19,5-23,5	38,0	26,0
3	53,5	101	19	14	6,5	6	48,5	96	19	71,0	137	8,0	170	217	94	24,5-32,5	48,0	35,0
4	66,0	130	32	19	8,5	8	59,0	123	26	94,5	171	9,5	212	276	114	35,0-46,0	64,5	53,5

Subject to technical alterations.

No. 6848HSNI

Horizontal hook-type toggle clamp with red handle and safety latch

Stainless steel, polished. Rivets running in greased bushes. Ergonomic, oil-resistant handle with large grip surface and soft components.

Supplied complete with counter catch. Also suitable for use in the food industry.



Order no.	Size	F1	Weight
		[kN]	[g]
93658	4	7,0	850

No. 6848HSNIY

Horizontal hook-type toggle clamp with yellow handle and safety latch



Order no.	Size	F1	Weight
		[kN]	[g]
557284	4	7,0	850

No. 6848HSNIJ

Horizontal hook-type toggle clamp with orange handle and safety latch



Order no.	Size	F1	Weight
		[kN]	[g]
557449	4	7,0	850

No. 6848HSNIE

Horizontal hook-type toggle clamp with blue handle and safety latch

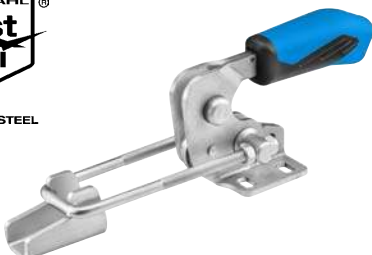

Order no.	Size	F1	Weight
		[kN]	[g]
557770	4	7,0	850

Subject to technical alterations.

No. 6848HSNIG

Horizontal hook-type toggle clamp with green handle and safety latch



Order no.	Size	F1	Weight
		[kN]	[g]
557606	4	7,0	850

No. 6848HSNIT

Horizontal hook-type toggle clamp with black handle and safety latch

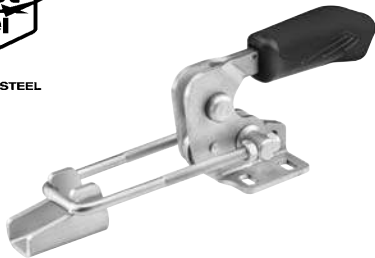

Order no.	Size	F1	Weight
		[kN]	[g]
558181	4	7,0	850

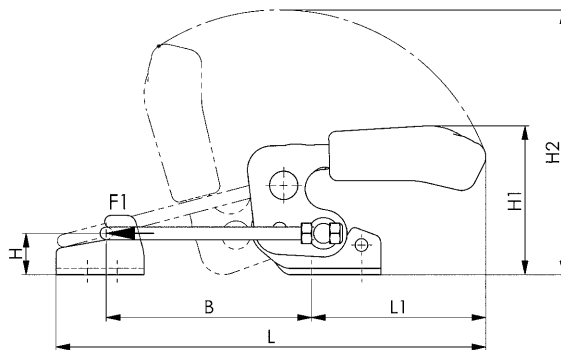
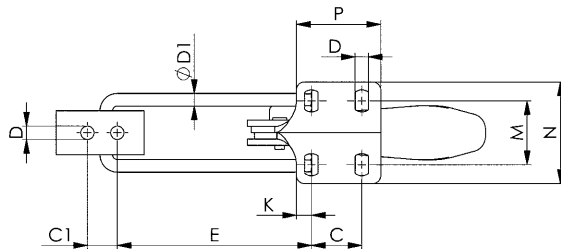

CAD

Recommendations



No. 6848GHNI, page 179



No. 6848HNI, page 98



No. 6847NI, page 96

Dimensions:

Size	B min.	B max.	C	C1	D	dia. D1	E min.	E max.	H	H1	H2	K	L min.	L max.	L1	M	N	P
4	66	130	32	19	8,5	8	59	123	26	94	168	9,5	209	273	111	35-46	64,5	53,5

Subject to technical alterations.

No. 6848VNI

Vertical hook-type toggle clamp with red handle

Stainless steel, polished. Rivets running in greased bushes. Ergonomic, oil-resistant handle with large grip surface and soft components.

Supplied complete with counter catch.

Also suitable for use in the food industry.



Order no.	Size	F1 [kN]	Weight [g]
95588	2	1,6	130
95604	3	3,2	340
95620	4	7,0	810

No. 6848VNIY

Vertical hook-type toggle clamp with yellow handle



Order no.	Size	F1 [kN]	Weight [g]
557285	2	1,6	130
557286	3	3,2	340
557287	4	7,0	810

No. 6848VNIJ

Vertical hook-type toggle clamp with orange handle



Order no.	Size	F1 [kN]	Weight [g]
557450	2	1,6	130
557451	3	3,2	340
557452	4	7,0	810

No. 6848VNIE

Vertical hook-type toggle clamp with blue handle



Order no.	Size	F1 [kN]	Weight [g]
557771	2	1,6	130
557772	3	3,2	340
557773	4	7,0	810

Subject to technical alterations.

No. 6848VNIG

Vertical hook-type toggle clamp with green handle



Order no.	Size	F1	Weight [g]
		[kN]	
557607	2	1,6	130
557608	3	3,2	340
557609	4	7,0	810

No. 6848VNIT

Vertical hook-type toggle clamp with black handle



Order no.	Size	F1	Weight [g]
		[kN]	
558182	2	1,6	130
558183	3	3,2	340
558184	4	7,0	810

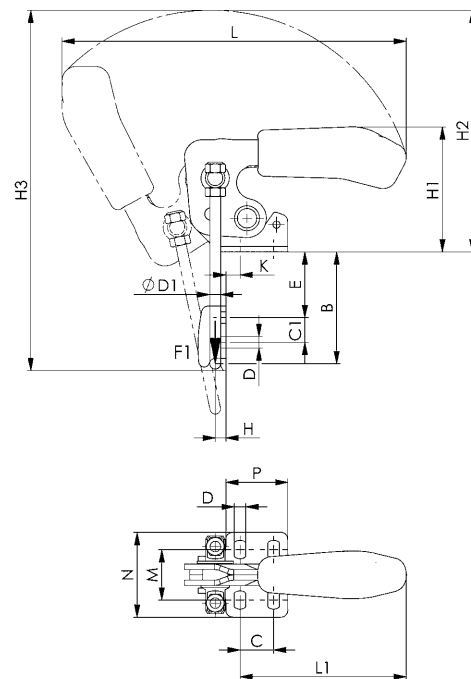

Recommendations



No. 6848GVNI, page 179



No. 6848HSNI, page 100



No. 6847NI, page 96

Dimensions:

Size	B min.	B max.	C	C1	D	dia. D1	E min.	E max.	H	H1	H2	H3	K	L	L1	M	N	P
2	24	47	13	11	5,2	4	5,0	28	4,5	47,0	99	150	6,8	158	69	19,5-23,5	38,0	26,0
3	33	63	19	14	6,5	6	6,5	36	6,0	70,0	137	172	8,0	195	93	24,5-32,5	48,0	35,0
4	43	81	32	19	8,5	8	9,0	47	8,0	94,5	168	254	9,5	239	111	35,0-46,0	64,5	53,5

Subject to technical alterations.



Subject to technical alterations.

AUTO-ADJUST TOGGLE CLAMPS

The benefits at a glance:

- > auto-adjust clamping height
- > clamps different workpiece types
- > ideal for small batch sizes
- > adjustable clamping force
- > ergonomic 2-component handle
- > retained on the clamp arm

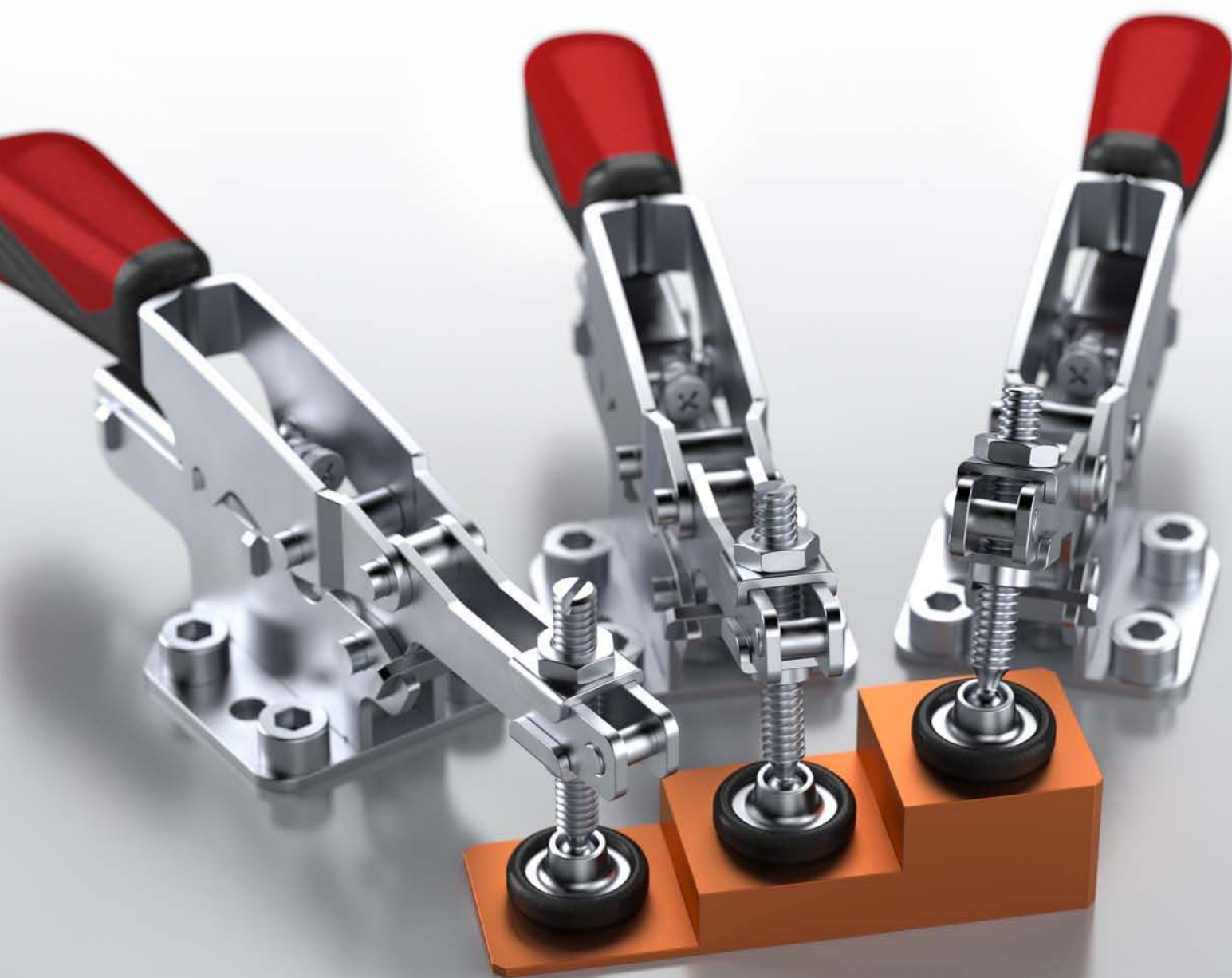

No. 6870F

Horizontal toggle clamp with auto-adjust clamping height

with open clamping arm and horizontal base.

Toggle clamp with continuous counterbalance function for workpieces with different clamping heights. Galvanised and passivated. Ergonomic, oil-resistant handle with large grip surface and soft components. Retainer for the clamping screw at the end of the clamp arm.

Complete with galvanised clamping screw.



CAD

Order no.	Size	F1 [kN]	Automatic height compensation S [mm]	Maximum height compensation [mm]	Clamping screw	Weight [g]
560895	20	2	20	35	M6 x 49	345
560896	50	3	35	40	M8 x 50	520
560897	70	3	35	60	M8 x 66	575

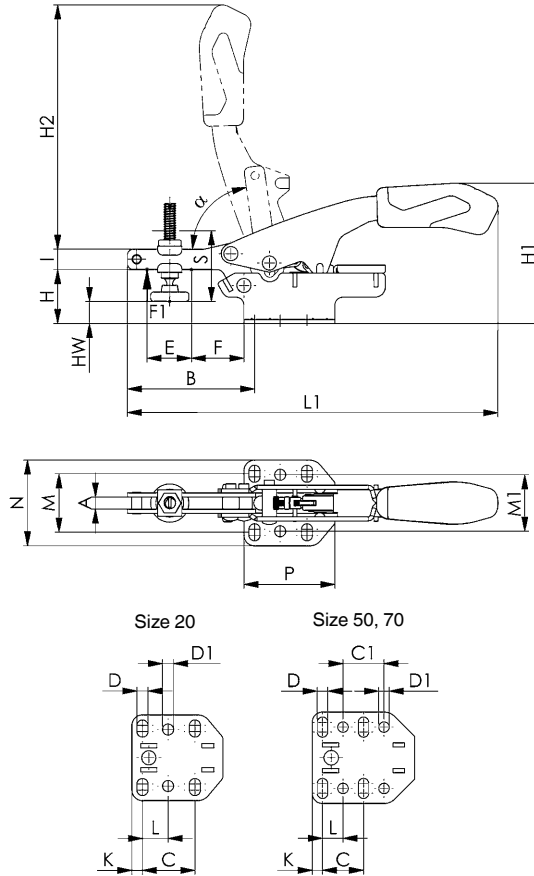

Recommendations



No. 6875, page 166

No. 6878K, page 172

No. 6878AR, page 174



Dimensions:

Order no.	Size	A	B	C	C1	D	D1	E	F	H	H1	H2	HW min.	HW max.	I	K	L	L1	M	M1	N	P	α
560895	20	6,1	63	26,0	-	5,5	5,5	22,0	26,0	27	70	121	-7,0	11,0	10	5,3	12,7	184	26 - 32	28	42,5	45,0	82 °
560896	50	8,4	104	25,4	25,4	6,5	6,5	35,2	22,2	23	72	174	-8,9	1,5	13	6,3	12,7	261	32 - 44	38	57,0	63,5	82 °
560897	70	8,5	104	25,4	25,4	6,5	6,5	35,0	50,0	41	90	174	-6,6	19,7	13	6,3	12,7	261	32 - 44	38	57,0	63,5	82 °

Subject to technical alterations.

No. 6871

Horizontal toggle clamp with auto-adjust clamping height

with open clamping arm and angle base.

Toggle clamp with continuous counterbalance function for workpieces with different clamping heights.

Galvanised and passivated. Ergonomic, oil-resistant handle with large grip surface and soft components. Retainer for the clamping screw at the end of the clamp arm.

Complete with galvanised clamping screw.



CAD

Order no.	Size	F1 [kN]	Automatic height compensation S [mm]	Maximum height compensation [mm]	Clamping screw	Weight [g]
554881	20	2	20	35	M6 x 49	272
554882	50	3	35	40	M8 x 66	544

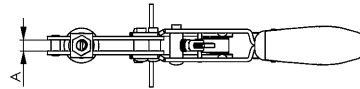
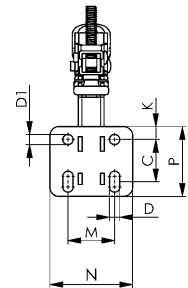
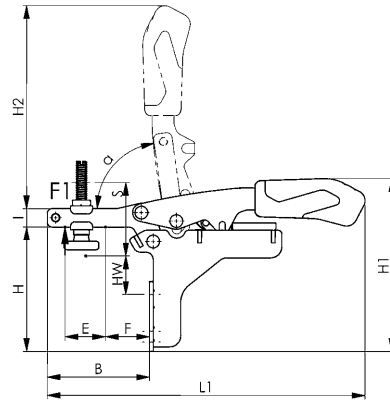

Recommendations



No. 6860, page 44



No. 68300, page 34



Dimensions:

Order no.	Size	A	B	C	D	D1	E	F	H	H1	H2	HW min.	HW max.	I	K	L1	M	N	P	α
554881	20	6,0	56	20,0 - 26,0	5,6	5,6	22	24	68	94	113	3	24	10	7,1	173	25,4	45	38	82°
554882	50	8,2	85	20,5 - 30,0	6,5	6,5	35	37	88	124	158	1	30	13	10,6	244	38,1	57	51	82°

Subject to technical alterations.

No. 6872

Horizontal toggle clamp with auto-adjust clamping height

with open clamping arm and vertical base.

Toggle clamp with continuous counterbalance function for workpieces with different clamping heights. Galvanised and passivated. Ergonomic, oil-resistant handle with large grip surface and soft components. Retainer for the clamping screw at the end of the clamp arm.

Complete with galvanised clamping screw.



Order no.	Size	F1 [kN]	Automatic height compensation S [mm]	Maximum height compensation [mm]	Clamping screw	Weight [g]
554883	20	2	20	35	M6 x 49	272
554884	50	3	35	40	M8 x 50	544

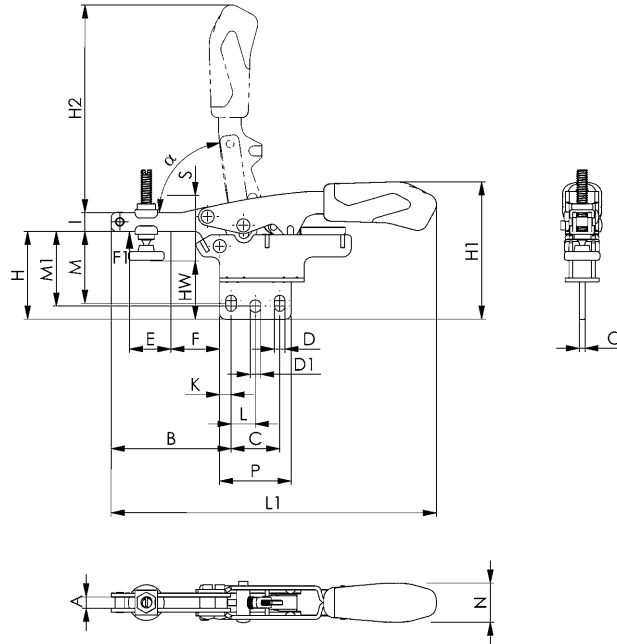

Recommendations



No. 6860,
page 44



No. 68300,
page 34

Dimensions:

Order no.	Size	A	B	C	D	D1	E	F	H	H1	H2	HW min.	HW max.	I	K	L	L1	M	M1	N	O	P	α
554883	20	6,0	64,0	25,9	5,6	5,6	22	26	47	73	113	13,5	31	10	6,0	13	173	37 - 40	39,8	21	3	38	82 °
554884	50	8,2	106,5	38,0	6,5	6,5	35	50	59	94,5	158	28,0	38	13	8,5	19	243	45 - 49	49,0	27	4	55	82 °

Subject to technical alterations.

No. 6874F

Push-pull type toggle clamp with auto-adjust clamping width

with horizontal base.

Toggle clamp with continuous counterbalance function for workpieces with different clamping widths.

Galvanised and passivated.

Ergonomic, oil-resistant handle with large grip surface and soft components. Retainer for the clamping screw at the end of the clamp arm.

Complete with galvanised clamping screw.



Order no.	Size	F1 [kN]	automatic stroke compensation S [mm]	maximum stroke compensation [mm]	Clamping screw	Weight [g]
560904	15	2	8	25	M6 x 37	230
560905	25	3	13	35	M8 x 50	550

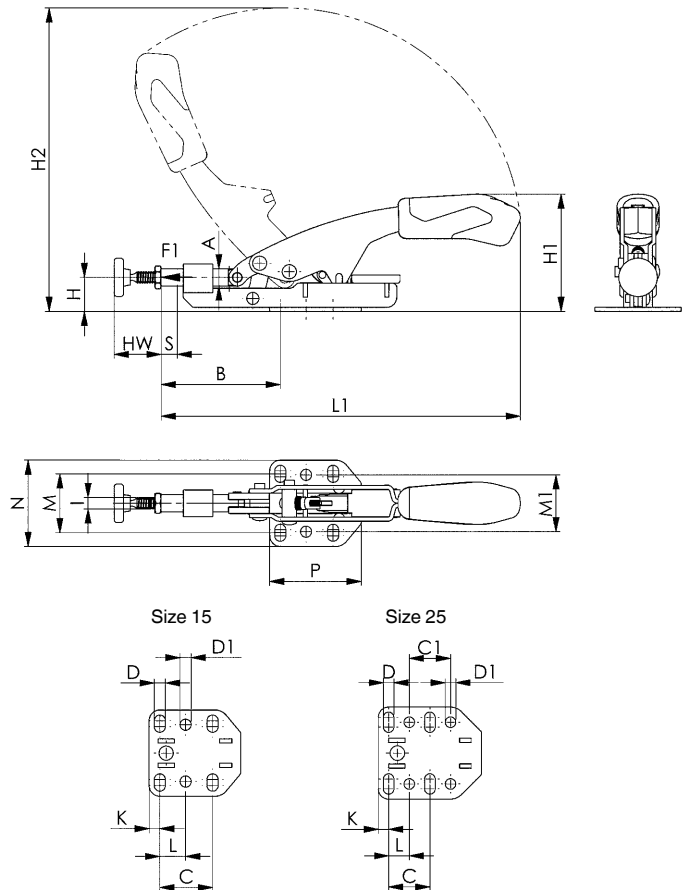

Recommendations



No. 6875, page 166



No. 6878K, page 172



No. 6878AR, page 174

Dimensions:

Order no.	Size	A	B	C	C1	D	D1	H	H1	H2	HW min.	HW max.	I	K	L	L1	M	M1	N	P
560904	15	8,5	52 - 69	26,0	-	5,5	5,5	16,8	58	145	13	25	M6	5,3	12,7	177	26 - 32	28	42,5	45,0
560905	25	11,8	72 - 98	25,4	25,4	6,5	6,5	23,2	71	207	16	35	M8	6,3	12,7	256	32 - 44	38	57,0	63,5

Subject to technical alterations.

No. 6873

Push-pull type toggle clamp with auto-adjust clamping width

with angle base.

Toggle clamp with continuous counterbalance function for workpieces with different clamping widths. Galvanised and passivated. Ergonomic, oil-resistant handle with large grip surface and soft components. Retainer for the clamping screw at the end of the clamp arm.

Complete with galvanised clamping screw.



Order no.	Size	F1 [kN]	automatic stroke compensation S [mm]	maximum stroke compensation [mm]	Clamping screw	Weight [g]
554885	15	2	8	25	M6 x 37	272
554886	25	3	13	35	M8 x 50	544

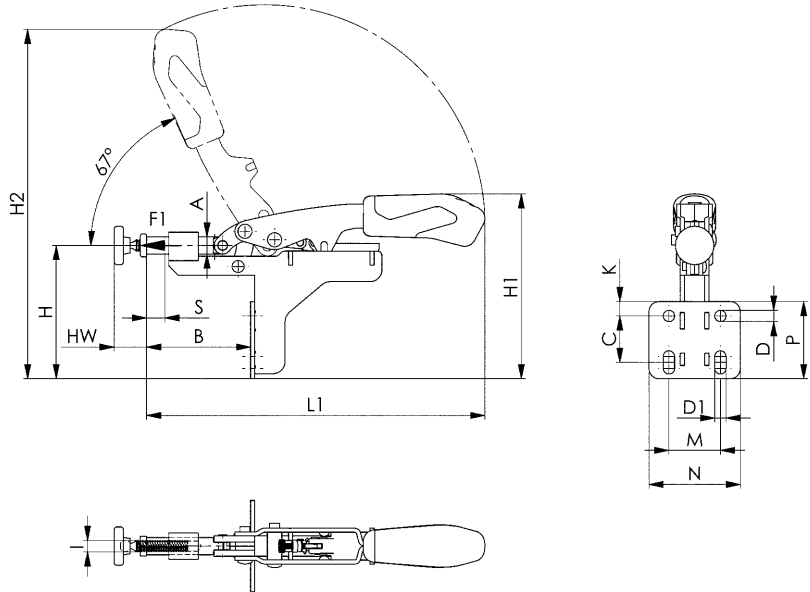

Recommendations



No. 6842,
page 54



No. 6841,
page 46

Dimensions:

Order no.	Size	A	B	C	D	D1	H	H1	H2	HW min.	HW max.	I	K	L1	M	N	P
554885	15	8,5	42 - 59	20 - 26	5,6	5,6	66	91	173	14	29	M6	7,1	167	25,4	45	38
554886	25	11,8	58 - 83	20,5 - 30,0	6,5	6,5	84	119	238	19	39	M8	10,6	236	38,1	57	51

Subject to technical alterations.

ESD TOGGLE CLAMPS

The ESD toggle clamps from AMF have been specially developed for working with electrostatically sensitive components, assemblies or devices in ESD protection zones (EPA) in accordance with the standard DIN EN 61340-5-1. All ESD toggle clamps from AMF have been tested and certified by an independent expert regarding leakage resistance, discharge time and surface tension.

The features at a glance:

- > Leakage resistance according to DIN IEC / TR 61340-5-2 between 10^{04} and 10^{09} Ohm
- > Discharge time according to DIN IEC/TR 61340-5-2 < 2 seconds
- > Surface tension (electric field strength) according to DIN EN 61340-5-1 < 100 Volt



No. 6800ESD

ESD vertical toggle clamp

With protective cap and handle made of electrostatic conductive (dissipative) material.

With open clamping arm and horizontal base.

Galvanised and passivated. Rivets made of stainless steel, which, for sizes 2 and 3, run in hardened bushings. Bearing positions are greased.

Ergonomic, oil-resistant handle with large grip surface and soft components. Safety clamping piece with finger protection, retainer for the clamping screw at the end of the clamping arm.

Complete with tempered, galvanised clamping screw No. 6890ESD.



CAD

Order no.	Size	F1 [kN]	F2 [kN]	Clamping screw	Weight [g]
562483	0	0,5	0,7	M4 x 25	60
562484	1	0,6	1,1	M5 x 30	105
562486	2	0,8	1,2	M6 x 35	175
562487	3	1,2	2,5	M8 x 45	410

Application:

The ESD toggle clamp has been specially developed for use in ESD protection zones (EPA – electrostatic protected area) for working on electrostatically sensitive components, assemblies or devices in accordance with the standard DIN EN 61340-5-1.

Features:

- Leakage resistance according to DIN IEC/TR 61340-5-2 between 10^{04} and 10^{09} Ohm
- Discharge time according to DIN IEC/TR 61340-5-2 < 2 Sekunden
- Surface tension (electric field strength) according to DIN EN 61340-5-1 < 100 Volt

Note:

The ESD vertical toggle clamp is non-insulating. It must not be used in areas where open voltages are used.

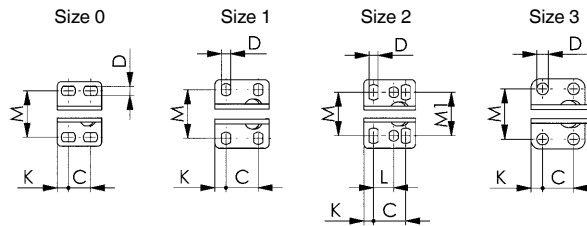
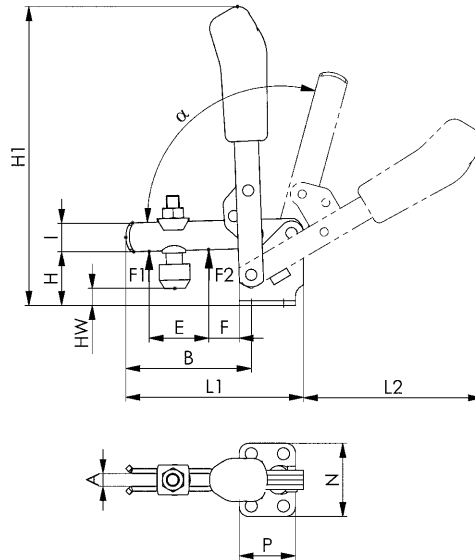

Recommendations



No. 6890ESD,
page 116

Dimensions:

Order no.	Size	A	B	C	D	E	F	H	H1	HW min.	HW max.	I	K	L	L1	L2	M	M1	N	P	α	α^*
562483	0	4	31	8,5 - 13,5	4,5	14	5,5	18	81	-1,5	3,5	8	5,5	-	49	50	23,0	-	32	22	95°	-
562484	1	5	39	16,0	4,5	18	6,0	19	98	-4,0	2,0	10	5,5	-	61	58	22,5 - 26,0	-	34	27	95°	-
562486	2	6	52	20,0	5,5	25	11,0	23	140	-3,0	4,5	12	6,0	12,5	78	89	23,0 - 31,0	27	43	32	105°	60°
562487	3	8	79	20,0	7,5	37	19,0	33	186	2,0	11,0	18	7,5	-	112	112	32,5	-	46	35	105°	60°

Subject to technical alterations.

No. 6830ESD

ESD horizontal toggle clamp

With protective cap and handle made of electrostatic conductive (dissipative) material.

With open clamping arm and horizontal base.

Galvanised and passivated. Rivets made of stainless steel, which, for sizes 2 and 3, run in hardened bushings. Bearing positions are greased.

Ergonomic, oil-resistant handle with large grip surface and soft components. Retainer for the clamping screw at the end of the clamp arm.

Complete with tempered, galvanised clamping screw No. 6890ESD.



CAD

Order no.	Size	F1 [kN]	F2 [kN]	Clamping screw	Weight [g]
562488	0	0,25	0,4	M4 x 25	35
562489	1	0,8	1,1	M5 x 30	105
562490	2	1,0	1,2	M6 x 35	185
562491	3	1,8	2,5	M8 x 45	320

Application:

The ESD horizontal toggle clamp has been specially developed for use in ESD protection zones (EPA – electrostatic protected area) for working on electrostatically sensitive components, assemblies or devices in accordance with the standard DIN EN 61340-5-1.

Features:

- Leakage resistance according to DIN IEC/TR 61340-5-2 between 10^{04} and 10^{09} Ohm
- Discharge time according to DIN IEC/TR 61340-5-2 < 2 Sekunden
- Surface tension (electric field strength) according to DIN EN 61340-5-1 < 100 Volt

Note:

The ESD horizontal toggle clamp is non-insulating. It must not be used in areas where open voltages are used.

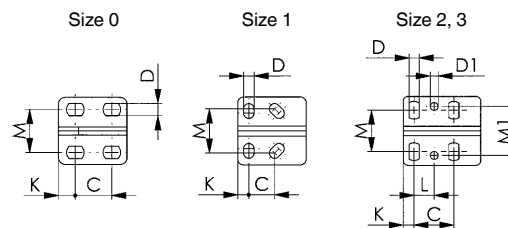
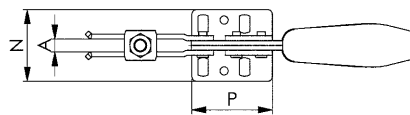
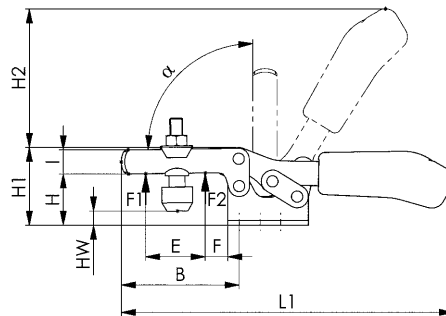

Recommendations



No. 6890ESD,
page 116

Dimensions:

Order no.	Size	A	B	C	D	D1	E	F	H	H1	H2	HW min.	HW max.	I	K	L	L1	M	M1	N	P	α
562488	0	4	28	11,5 - 15,5	4,6	-	9,0	5,5	14,5	23,0	34	-5,5	0,0	7,5	6,3	-	79	16,0	-	25,0	25,5	90°
562489	1	5	42	13,0 - 14,5	5,2	-	18,7	8,0	19,0	30,0	49	-3,0	2,5	10,0	5,5	-	120	18,0 - 21,5	-	34,0	34,0	90°
562490	2	6	64	26,0	5,6	5,6	32,0	16,0	24,0	45,0	68	-1,5	5,0	13,2	6,0	12,7	162	19,5 - 29,5	28,5	42,0	38,0	90°
562491	3	8	73	25,7	6,5	5,1	38,0	14,0	32,0	48,5	86	-2,0	9,0	15,0	7,0	13,0	206	22,0 - 31,8	31,6	45,5	50,0	90°

Subject to technical alterations.

No. 6840ESD

ESD push-pull type toggle clamp

With protective cap and handle made of electrostatic conductive (dissipative) material.

Without angle base. Push and pull-clamping (Equal operation of rod and lever). Long rod-guide with attaching thread and nut.

Galvanised and passivated. Rivets made of stainless steel, which, for sizes 2 and 3, run in hardened bushings. Lever-parts and push-pull type toggle clamp made of tempered steel. Bearing positions are greased. Push-pull toggle clamp with threaded front for direct mounting in vertical metal plates or in fixtures.

Ergonomic, oil-resistant handle with large grip surface and soft components.

Complete with tempered, galvanised clamping screw No. 6880ESD.



Order no.	Size	F1 [kN]	F2 [kN]	Clamping screw	Weight [g]
562492	0	0,8	0,8	M4 x 20	60
562493	1	1,0	1,0	M4 x 20	100
562494	2	2,0	2,0	M6 x 25	245
562495	3	2,5	2,5	M8 x 35	330

Application:

The ESD push-pull type toggle clamp has been specially developed for use in ESD protection zones (EPA – electrostatic protected area) for working on electrostatically sensitive components, assemblies or devices in accordance with the standard DIN EN 61340-5-1.

Features:

- Leakage resistance according to DIN IEC/TR 61340-5-2 between 10^{04} and 10^{09} Ohm
- Discharge time according to DIN IEC/TR 61340-5-2 < 2 seconds
- Surface tension (electric field strength) according to DIN EN 61340-5-1 < 100 Volt

Note:

The ESD push-pull type toggle clamp is non-insulating. It must not be used in areas where open voltages are used.

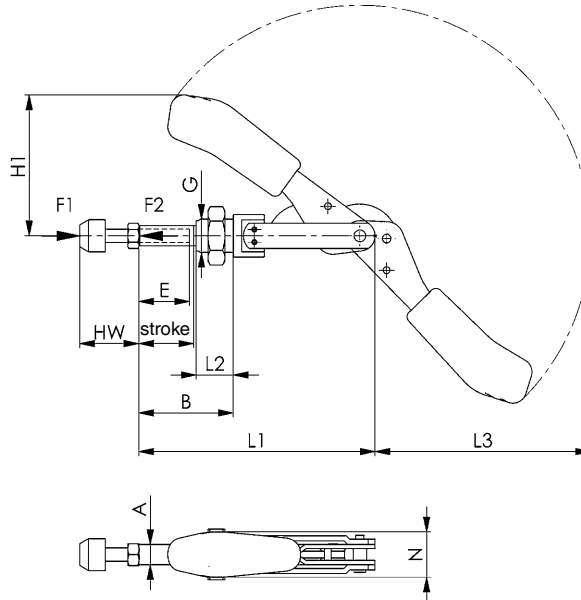

Recommendations



No. 6843,
page 52



No. 6880ESD,
page 116

Dimensions:

Order no.	Size	A	B min.	B max.	E	G	H1	Stroke	HW min.	HW max.	L1	L2	L3	N
562492	0	6,5	10,5	26,5	13	M10 x 1,0	37,0	16	12	20	66,5	10	54	15
562493	1	8,0	17,5	37,5	20	M12 x 1,5	45,5	20	12	20	91,0	16	74	18
562494	2	10,0	20,0	46,0	20	M16 x 1,5	66,0	26	17	25	114,0	19	105	22
562495	3	12,0	24,0	56,0	30	M20 x 1,5	82,5	32	22	35	140,0	22	127	27

Subject to technical alterations.

No. 6844ESD

ESD push-pull type toggle clamp

With protective cap and handle made of electrostatic conductive (dissipative) material.

short version. For push and pull-clamping. Long rod-guide with attaching thread and nut.

Galvanised and passivated. Piston rod is made of non-rusting steel. Shoulder screws tempered. Bearing positions are greased.

Ergonomic, oil-resistant handle with large grip surface and soft components.

Complete with tempered, galvanised clamping screw No. 6880ESD.



CAD

Order no.	Size	F1 [kN]	F2 [kN]	Clamping screw	Weight [g]
562496	2	1,0	1,0	M6 x 25	130
562497	3	2,5	2,5	M8 x 35	320

Application:

The ESD push-pull type toggle clamp has been specially developed for use in ESD protection zones (EPA – electrostatic protected area) for working on electrostatically sensitive components, assemblies or devices in accordance with the standard DIN EN 61340-5-1.

Features:

- Leakage resistance according to DIN IEC/TR 61340-5-2 between 10^{04} and 10^{09} Ohm
- Discharge time according to DIN IEC/TR 61340-5-2 < 2 Sekunden
- Surface tension (electric field strength) according to DIN EN 61340-5-1 < 100 Volt

Note:

The ESD push-pull type toggle clamp is non-insulating. It must not be used in areas where open voltages are used.

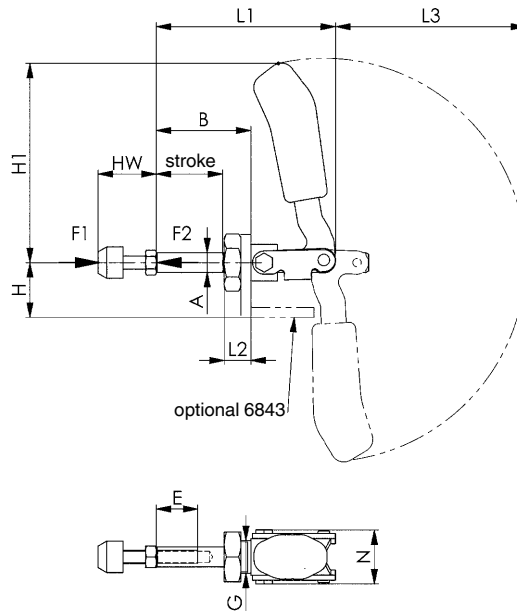

Recommendations



No. 6843,
page 52



No. 6880ESD,
page 116

Dimensions:

Order no.	Size	A	B	E	G	H	H1	Stroke	HW min.	HW max.	L1	L2	L3	N
562496	2	10	36	15	M16 x 1,5	24	73	21,5	17	25	68,5	13	68	30,5
562497	3	12	57	25	M20 x 1,5	33	123	40,0	22	35	108,0	16	115	33,0

Subject to technical alterations.

No. 6890ESD

ESD clamping screw

With protective cap made of electrostatic conductive (dissipative) material.

For open clamping arms, tempered, galvanized and passivated. Tensile strength class 8.8, with removable protective cap and nut-washer element.



CAD

Order no.	Size	Screw DIN 933	Washer size	D	D1	L	L3	Weight [g]
562598	0	M4 x 25	0	11,0	7	32	13 - 20	5
562599	1	M5 x 30	1	12,5	8	38	17 - 24	10
562600	2	M6 x 35	2	15,0	10	45	18 - 28	22
562601	3	M8 x 45	3	19,0	13	58	22 - 34	40



Application:

The ESD clamping screw has been specially developed for use in ESD protection zones (EPA – electrostatic protected area) for working on electrostatically sensitive components, assemblies or devices in accordance with the standard DIN EN 61340-5-1.

Features:

- Leakage resistance according to DIN IEC/TR 61340-5-2 between 10^{04} and 10^{09} Ohm
- Discharge time according to DIN IEC/TR 61340-5-2 < 2 Sekunden
- Surface tension (electric field strength) according to DIN EN 61340-5-1 < 100 Volt

Note:

The ESD clamping screw is non-insulating. It must not be used in areas where open voltages are used.

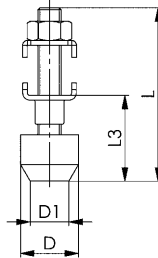

No. 6880ESD

ESD clamping screw

With protective cap made of electrostatic conductive (dissipative) material.

For push-pull type toggle clamps, tempered, galvanized and passivated. Tensile strength class 8.8, with nut and removable protective cap.



CAD

Order no.	Size	Screw DIN 933	D	D1	L	L3	Weight [g]
562602	0+1	M4 x 20	11,0	7	27	12 - 20	4
562603	2	M6 x 25	15,0	10	35	17 - 25	15
562604	3	M8 x 35	19,0	13	48	22 - 35	26



Application:

The ESD clamping screw has been specially developed for use in ESD protection zones (EPA – electrostatic protected area) for working on electrostatically sensitive components, assemblies or devices in accordance with the standard DIN EN 61340-5-1.

Features:

- Leakage resistance according to DIN IEC/TR 61340-5-2 between 10^{04} and 10^{09} Ohm
- Discharge time according to DIN IEC/TR 61340-5-2 < 2 Sekunden
- Surface tension (electric field strength) according to DIN EN 61340-5-1 < 100 Volt

Note:

The ESD clamping screw is non-insulating. It must not be used in areas where open voltages are used.

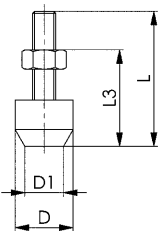

AMF TOGGLE CLAMPS FOR OPTICAL MEASUREMENT TECHNOLOGY

The new black toggle clamps are especially suited for the optical measurement of workpieces. The complete matte-black surface of the clamps prevents reflections. As a result, in the later evaluation of the measurement results on the PC, all unneeded clamp parts can be suppressed and only the actual workpiece is visible.

All black toggle clamps are blackened using a special process. This offers effective protection against corrosion and film rust formation. In addition, environmentally damaging emissions are not created with this process.

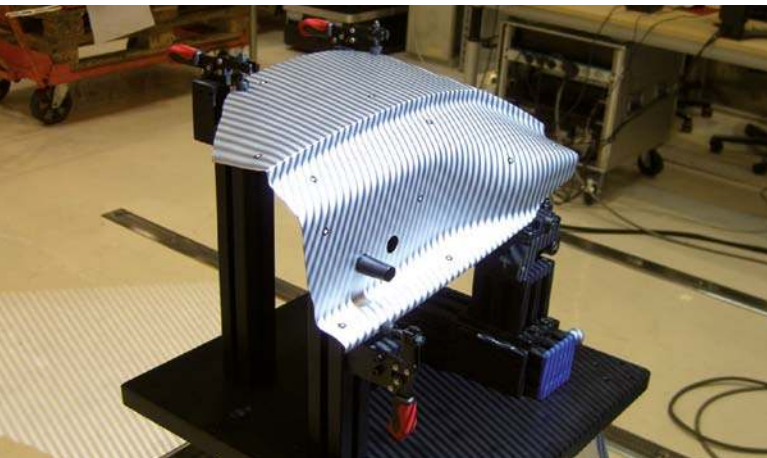

MARKING AND MEASURING OF THE WORKPIECE

For overlaying of several pictures, circular markings are attached to the object. A stripe pattern is projected onto the object surface by a white-light projector and photographed by two cameras from different angles of view.

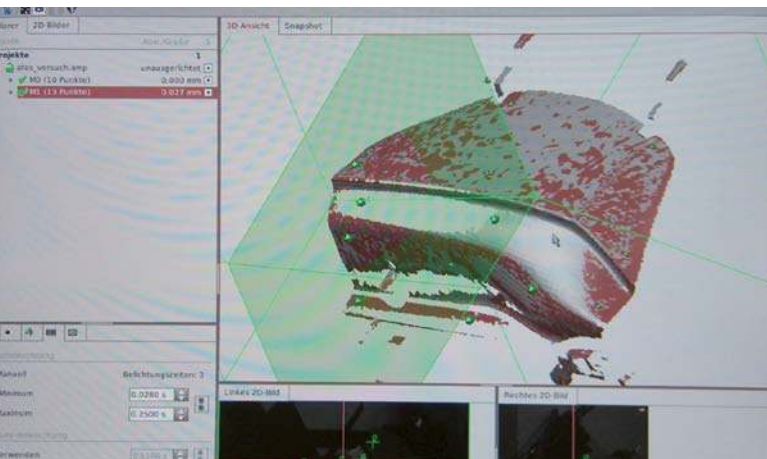

EVALUATION

Within seconds, highly precise 3D coordinates of up to 4 million object points per measurement are calculated. For this, the black device with the black toggle clamps are „suppressed“.

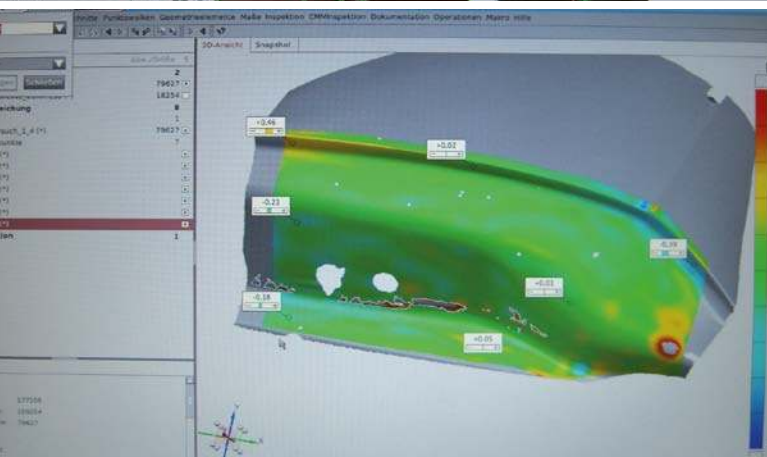

VISUALISATION AND RESULT

Variances from the CAD are calculated. The 3D coordinates of the measurement points can be measured exactly and visualised in colour.

The complete 3D data set and the comparison results can be exported into common formats for further processing.

No. 6800B

Vertical toggle clamp, black

With open clamping arm and horizontal base.

Matte black surface. Rivets made of stainless steel, which, for sizes 2 and 3, run in hardened bushings. Bearings are pre-lubricated.

Ergonomic, oil-resistant black handle with large grip surface and soft components. Safety clamping piece with finger protection. Lock washer for the thrust bolt at the end of the clamping arm.

Complete with tempered, matte-black clamping screw no. 6890B.

Order no.	Size	F1 [kN]	F2 [kN]	Clamping screw	Weight [g]
90167	0	0,5	0,7	M4x34,5	60
90175	1	0,6	1,1	M5x38,0	105
90183	2	0,8	1,2	M6x46,0	175
90191	3	1,2	2,5	M8x63,0	410

Note:

These clamps are suitable for photogrammetric use. The matte-black surface of the clamps prevents reflection while photographing.

For suitable clamping arm extension see no. 6896.

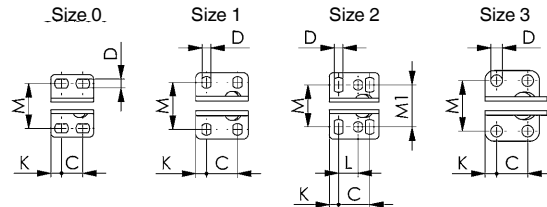
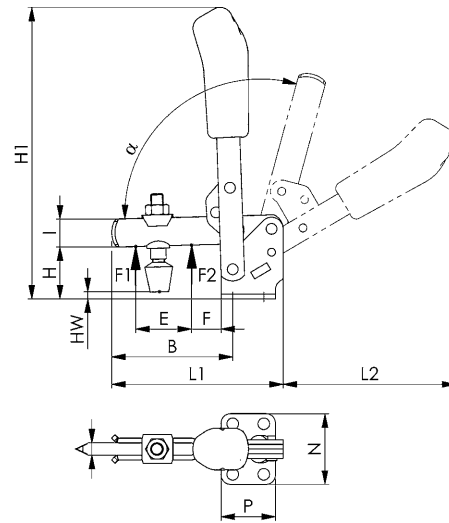

Recommendations



No. 6890B,
page 165



No. 6802B,
page 119



No. 6800BS,
page 125

Dimensions:

Order no.	Size	A	B	C	D	E	F	H	H1	HW min.	HW max.	I	K	L	L1	L2	M	M1	N	P	α	α^*
90167	0	4	32	8,5-13,5	4,5	14	5,5	18	81,0	-4,0	6,5	8	5,5	-	49,0	50,0	23,0	-	32	22	95°	-
90175	1	5	39	16	4,5	18	6,0	19	97,5	-3,7	1,6	10	5,5	-	61,0	58,0	22,5-26	-	34	27	95°	-
90183	2	6	52	20	5,5	25	11,0	23	140,0	-4,4	4,4	12	6,0	12,5	78,0	89,0	23,0-31	25,5-28,5	43	32	105°	60°
90191	3	8	79	20	7,5	36	19,0	33	188,0	-2,8	7,0	18	7,5	-	111,5	111,5	32,5	-	46	35	105°	60°

* The opening angle can be changed by pressing in a stop pin.



CAD

No. 6802B

Vertical toggle clamp, black

With open clamping arm and vertical base.

Matte black surface. Rivets made of stainless steel, which, for sizes 2 and 3, run in hardened bushings. Bearings are pre-lubricated.

Ergonomic, oil-resistant black handle with large grip surface and soft components. Safety clamping piece with finger protection. Lock washer for the thrust bolt at the end of the clamping arm.

Complete with tempered, matte-black clamping screw no. 6890B.

Order no.	Size	F1 [kN]	F2 [kN]	Clamping screw	Weight [g]
90415	1	0,6	1,1	M5x38	105
90472	2	0,8	1,2	M6x46	175
90498	3	1,2	2,5	M8x63	410

Note:

These clamps are suitable for photogrammetric use. The matte-black surface of the clamps prevents reflection while photographing.

For suitable clamping arm extension see no. 6896.

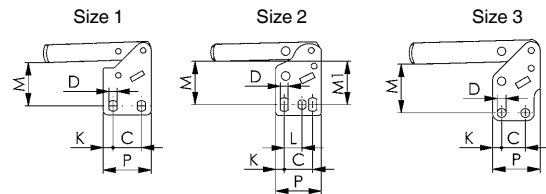
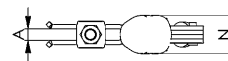
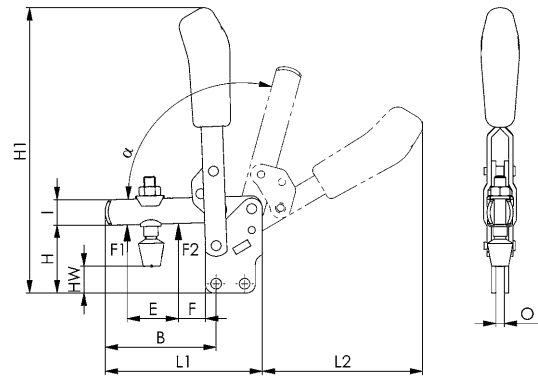

Recommendations



No. 6890B,
page 165



No. 6802BS,
page 126



No. 6841B,
page 124

Dimensions:

Order no.	Size	A	B	C	D	E	F	H	H1	HW min.	HW max.	I	K	L	L1	L2	M	M1	N	O	P	α	α^*
90415	1	5	39	16	4,5	18	6	29	110,5	6,8	12	10	5,5	-	61	58	23,5-25	-	19	5	27	95°	-
90472	2	6	52	20	5,5	25	11	38	144,5	10,5	19	12	6,0	12,5	78	80	28,5-32,5	30-31	21	5	32	105°	60°
90498	3	8	79	20	7,5	36	19	48	201,0	11,4	21	18	7,5	-	112	113	41	-	27	6	40	105°	60°

* The opening angle can be changed by pressing in a stop pin.



No. 6830B

Horizontal toggle clamp, black

With open clamping arm and horizontal base.

Matte black surface. Rivets made of stainless steel, which, for sizes 2 and 3, run in hardened bushings. Bearings are pre-lubricated.

Ergonomic, oil-resistant black handle with large grip surface and soft components. Lock washer for the thrust bolt at the end of the clamping arm.

Complete with tempered, matte-black clamping screw no. 6890B.

Order no.	Size	F1 [kN]	F2 [kN]	Clamping screw	Weight [g]
90423	0	0,3	0,4	M4x34,5	35
90480	1	0,8	1,1	M5x38	105
90506	2	1,0	1,2	M6x46	185
90522	3	1,8	2,5	M8x63	320

Note:

These clamps are suitable for photogrammetric use. The matte-black surface of the clamps prevents reflection while photographing.

For suitable clamping arm extension see no. 6896.

For suitable sensor monitor for size 3 see no. 6897S.

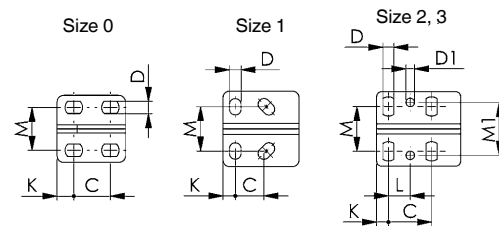
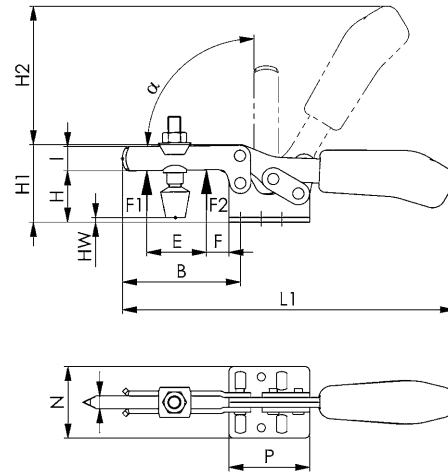

Recommendations



No. 6890B,
page 165



No. 6832B,
page 121



No. 6841B,
page 124

Dimensions:

Order no.	Size	A	B	C	D	D1	E	F	H	H1	H2	HW min.	HW max.	I	K	L	L1	M	M1	N	P	α
90423	0	4	28	11,5-15,5	4,6	-	9,0	5,5	14,5	23,0	34,0	-7,4	2,7	7,5	6,25	-	79	16,0	-	25,0	25,5	90°
90480	1	5	42	13,0-14,5	5,2	-	18,8	8,0	19,0	30,0	49,0	-3,6	1,8	10,0	5,50	-	120	18,0-21,5	-	34,0	34,0	90°
90506	2	6	64	26,0	5,6	5,6	32,0	16,0	24,0	45,0	66,3	-2,6	5,0	13,2	6,00	12,7	162	19,5-29,5	28,5	42,0	38,0	90°
90522	3	8	73	25,7	6,5	5,1	37,0	14,0	32,0	48,5	86,0	-7,4	5,0	15,0	7,00	-	206	21,5-32,0	31,6	45,5	50,0	90°

CAD



Subject to technical alterations.

No. 6832B

Horizontal toggle clamp, black

With open clamping arm and vertical base.

Matte black surface. Rivets made of stainless steel, which, for sizes 2 and 3, run in hardened bushings. Bearings are pre-lubricated.

Ergonomic, oil-resistant black handle with large grip surface and soft components. Lock washer for the thrust bolt at the end of the clamping arm.

Complete with tempered, matte-black clamping screw no. 6890B.

Order no.	Size	F1 [kN]	F2 [kN]	Clamping screw	Weight [g]
90290	0	0,3	0,4	M4x34,5	35
90308	1	0,8	1,1	M5x38	105
482471	1	0,8	1,1	-	95
90530	2	1,0	1,2	M6x46	185
456400	2	1,0	1,2	-	170
90381	3	1,8	2,5	M8x63	320
482497	3	1,8	2,5	-	280

Note:

These clamps are suitable for photogrammetric use. The matte-black surface of the clamps prevents reflection while photographing.

For suitable clamping arm extension see no. 6896.

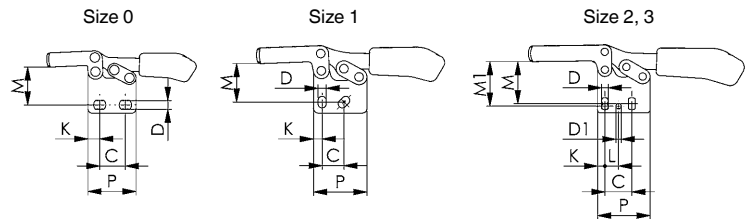
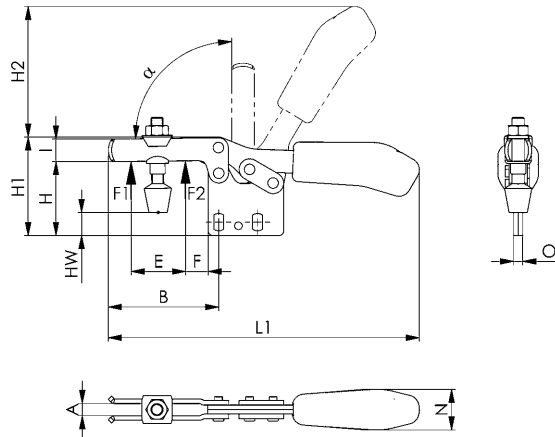

Recommendations



No. 6890B,
page 165



No. 6830B,
page 120



No. 6800B,
page 118

Dimensions:

Order no.	Size	A	B	C	D	D1	E	F	H	H1	H2	HW min.	HW max.	I	K	L	L1	M	M1	N	O	P	α
90290	0	4	28,0	11,5-15,5	4,6	-	9,0	5,5	24,5	33	34	2,2	13,7	7,5	6,25	-	79,0	20,0	-	12	3	25,5	90°
90308	1	5	41,7	13,0-15,0	5,2	-	18,5	8,0	31,5	43	49	8,9	14,8	10,0	5,50	-	119,7	23,5-25,5	-	18	5	34,0	90°
482471	1	5	41,7	13,0-15,0	5,5	-	18,5	8,0	31,5	43	49	-	-	10,0	5,50	-	119,7	23,5-25,5	-	18	5	34,0	90°
90530	2	6	64,0	26,0	5,6	5,6	32,0	16,0	40,0	61	68	14,0	22,0	13,2	6,00	12,7	164,0	29,5-34,0	34,0	21	5	38,0	90°
456400	2	6	64,0	26,0	5,6	5,6	32,0	16,0	40,0	61	68	-	-	13,2	6,00	12,7	164,0	29,5-34,0	34,0	21	5	38,0	90°
90381	3	8	73,0	25,7	6,5	5,1	39,0	12,0	49,0	65	86	9,5	22,0	15,0	7,00	13,0	206,0	37,5-42,5	42,0	27	6	50,0	90°
482497	3	8	73,0	25,7	6,5	5,1	39,0	12,0	49,0	65	86	-	-	15,0	7,00	13,0	206,0	37,5-42,5	42,0	27	6	50,0	90°



No. 6835B-2

Horizontal toggle clamp, black

With open clamping arm and vertical, open base.

Matte black surface. Stainless steel rivets, which run in hardened bushes. Bearings are pre-lubricated.

Ergonomic, oil-resistant black handle with large grip surface and soft components. Lock washer for the thrust bolt at the end of the clamping arm.

Order no.	Size	F1 [kN]	F2 [kN]	Weight [g]
90670	2	1,0	1,2	190

Note:

These clamps are suitable for photogrammetric use. The matte-black surface of the clamps prevents reflection while photographing.

For suitable clamping arm extension see no. 6896.

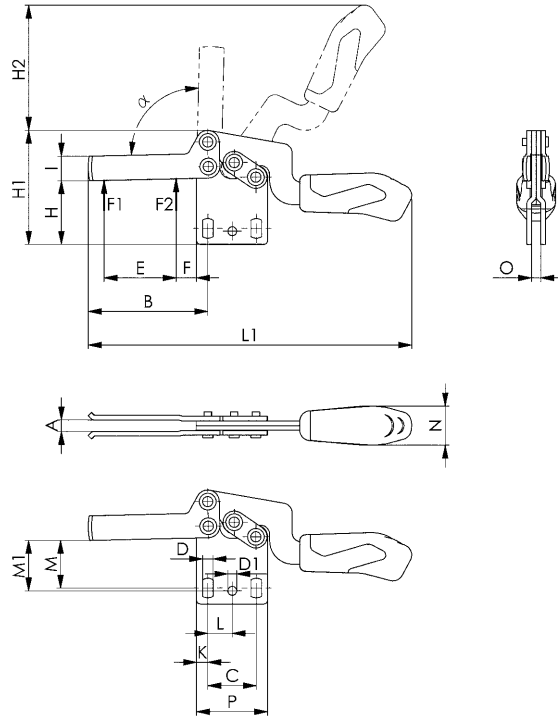

Recommendations



No. 6896,
page 171



No. 6890B,
page 165

Dimensions:

Order no.	Size	A	B	C	D	D1	E	F	H	H1	H2	I	K	L	L1	M	M1	N	O	P	α
90670	2	6,2	64	26,0	5,6	4,8	38,6	11,0	34	61	67	13,2	6	13,1	173,5	23,0-28,0	27	21	5	38	90°

CAD



Subject to technical alterations.

No. 6835B-3

Horizontal toggle clamp, black

With open clamping arm and vertical, open base.

Matte black surface. Stainless steel rivets, which run in hardened bushes. Bearings are pre-lubricated.

Ergonomic, oil-resistant black handle with large grip surface and soft components. Lock washer for the thrust bolt at the end of the clamping arm.

Order no.	Size	F1 [kN]	F2 [kN]	Weight [g]
90696	3	1,8	2,5	320

Note:

These clamps are suitable for photogrammetric use. The matte-black surface of the clamps prevents reflection while photographing.

For suitable clamping arm extension see no. 6896.

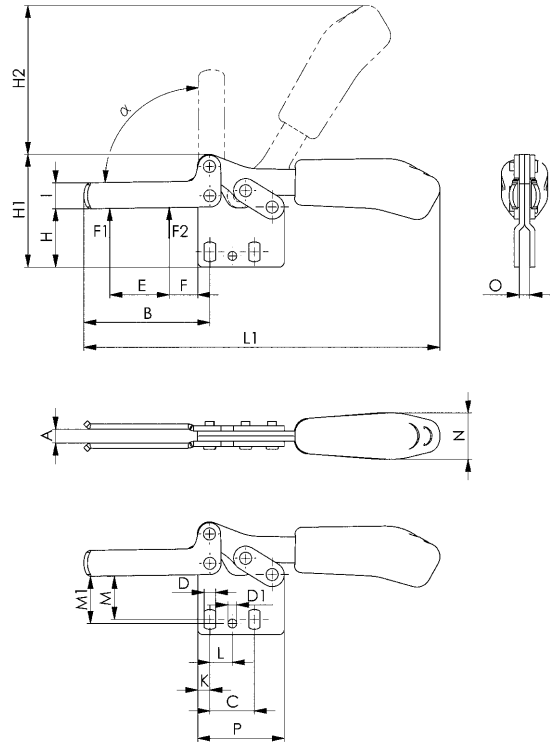

Recommendations



No. 6896,
page 171



No. 6890B,
page 165

Dimensions:

Order no.	Size	A	B	C	D	D1	E	F	H	H1	H2	I	K	L	L1	M	M1	N	O	P	α
90696	3	8,0	73	25,7	6,5	5,1	34,5	16,5	34	65	86	15,0	7	13,0	206,0	22,5-27,5	27	27	6	50	90°



CAD

No. 6841B

Push-pull type toggle clamp, black

With small angle base. Push- and pull-clamping. (Equal operation of rod and lever). Long rod-guide with attaching thread and nut. Matte black surface. Stainless steel rivets. Lever-parts and rod of tempered steel. Bearings are pre-lubricated. Ergonomic, oil-resistant black handle with large grip surface and soft components. Lever can be set to any angle relative to base.

Complete with tempered, matte-black clamping screw no. 6880B.



Order no.	Size	F1 [kN]	F2 [kN]	Clamping screw	Weight [g]
90548	1	1,0	1,0	M4x20	125
91280	2	2,0	2,0	M6x25	245

Note:

These clamps are suitable for photogrammetric use. The matte-black surface of the clamps prevents reflection while photographing.

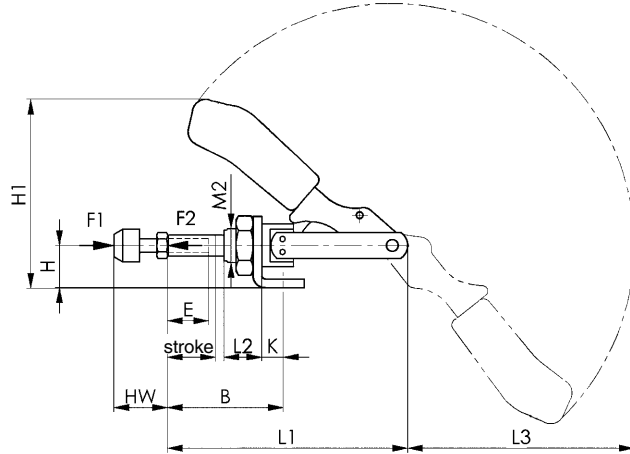

Recommendations



No. 6880B,
page 167



No. 6800B,
page 118



No. 6830B,
page 120

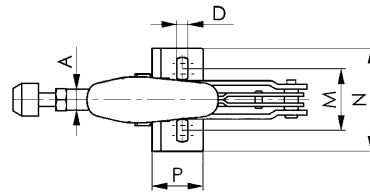

Dimensions:

Order no.	Size	A	B min.	B max.	D	E	H	H1	Stroke	HW min.	HW max.	K	L1	L2	L3	M	M2	N	P
90548	1	8,0	24,5	44,5	4,5	20	15	60	20	12	20	7,0	91	16	72	16,0-19,5	M12x1,5	30	20
91280	2	10,0	32,5	57,5	5,6	25	20	95	26	17	25	12,5	114	19	105	31,8-36,0		50	34

No. 6845B

Push-pull type toggle clamp, black

Push clamp.

(Opposed operation of rod and lever). Version with long rod guide. Basic body of malleable cast iron, matt black surface. Lever parts and rod of tempered steel, matte-black galvanised. Stainless steel rivets, which run in hardened bushes. Bearings are pre-lubricated. Ergonomic, oil-resistant handle with large grip surface and soft components.

Complete with tempered, matte-black clamping screw no. 6880B-3.



Order no.	Size	F1 [kN]	Clamping screw	Weight [g]
99663	3	4	M8 x 44	540

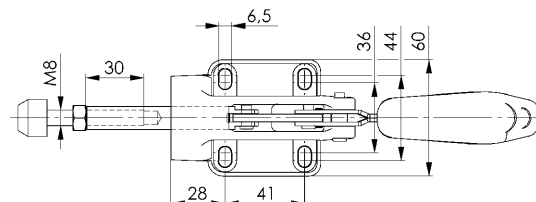
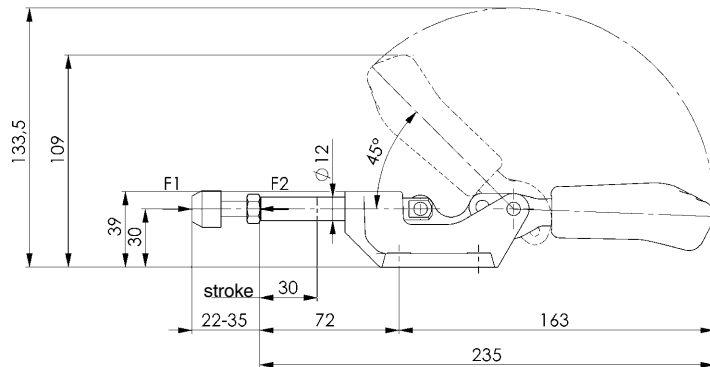

Subject to technical alterations.

No. 6800BS

Vertical toggle clamp with safety latch, black

For open and clamped positions. With open clamping arm and horizontal base.

Matte black surface. Stainless steel rivets, which run in hardened bushes. Bearings are pre-lubricated.

Ergonomic, oil-resistant black handle with large grip surface and soft components. Safety clamping piece with finger protection.

Lock washer for the thrust bolt at the end of the clamping arm.

Complete with tempered, matte-black clamping screw no. 6890B.

Order no.	Size	F1 [kN]	F2 [kN]	Clamping screw	Weight [g]
91348	2	1,0	1,2	M6x46	260

Note:

These clamps are suitable for photogrammetric use. The matte-black surface of the clamps prevents reflection while photographing.

For suitable clamping arm extension see no. 6896.

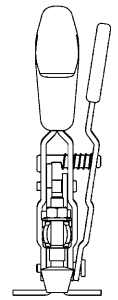
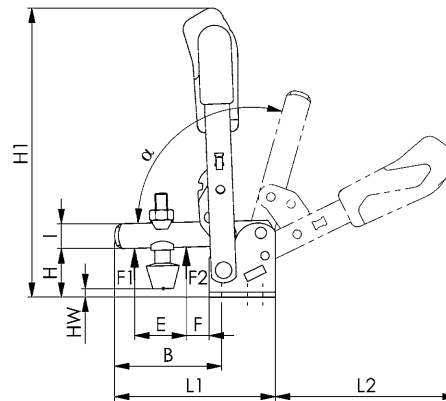
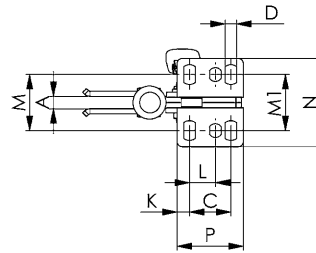

Recommendations



No. 6890B,
page 165



No. 6800B,
page 118



No. 6802B,
page 119

Dimensions:

Order no.	Size	A	B	C	D	E	F	H	H1	HW min.	HW max.	I	K	L	L1	L2	M	M1	N	P	α	α^*
91348	2	6	52	20	5,5	26	11	23	139	-4,4	4,4	12	6	12,5	78	88	23-31	25,5-28,5	43	32	105°	60°

* The opening angle can be changed by pressing in a stop pin.



CAD

No. 6802BS

Vertical toggle clamp with safety latch, black

For open and clamped positions. With open clamping arm and vertical base.

Matte black surface. Stainless steel rivets, which run in hardened bushes. Bearings are pre-lubricated.

Ergonomic, oil-resistant black handle with large grip surface and soft components. Safety clamping piece with finger protection. Lock washer for the thrust bolt at the end of the clamping arm.

Complete with tempered, matte-black clamping screw no. 6890B.

Order no.	Size	F1 [kN]	F2 [kN]	Clamping screw	Weight [g]
99689	3	1,2	2,5	M8x63	470

Note:

These clamps are suitable for photogrammetric use. The matte-black surface of the clamps prevents reflection while photographing.

For suitable clamping arm extension see no. 6896.

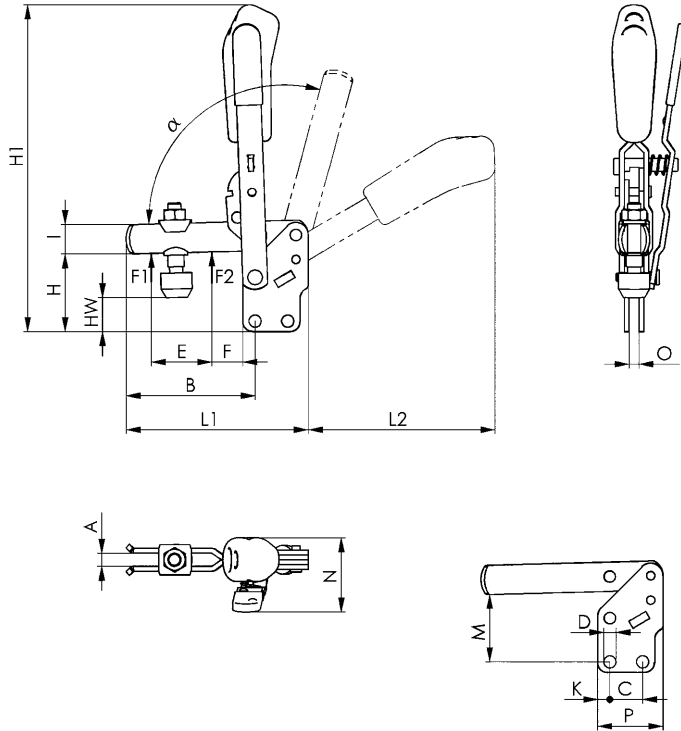

Recommendations



No. 6890B,
page 165



No. 6802B,
page 119



No. 6800B,
page 118

Dimensions:

Order no.	Size	A	B	C	D	E	F	H	H1	HW min.	HW max.	I	K	L1	L2	M	N	O	P	α	α*
99689	3	8	79	20	7,5	37	19	48	200	16,5	25	18	7,5	112	114	41	45,5	6	40	105°	60°

* The opening angle can be changed by pressing in a stop pin.

CAD



Subject to technical alterations.

No. 6832BS

Horizontal toggle clamp with safety latch, black

For open and clamped positions. With open clamping arm and vertical base.

Matte black surface. Stainless steel rivets, which run in hardened bushes. Bearings are pre-lubricated.

Ergonomic, oil-resistant black handle with large grip surface and soft components. Lock washer for the thrust bolt at the end of the clamping arm.

Complete with tempered, matte-black clamping screw no. 6890B.

Order no.	Size	F1 [kN]	F2 [kN]	Clamping screw	Weight [g]
99648	3	1,8	2,5	M8x63	390

Note:

These clamps are suitable for photogrammetric use. The matte-black surface of the clamps prevents reflection while photographing.

For suitable clamping arm extension see no. 6896.

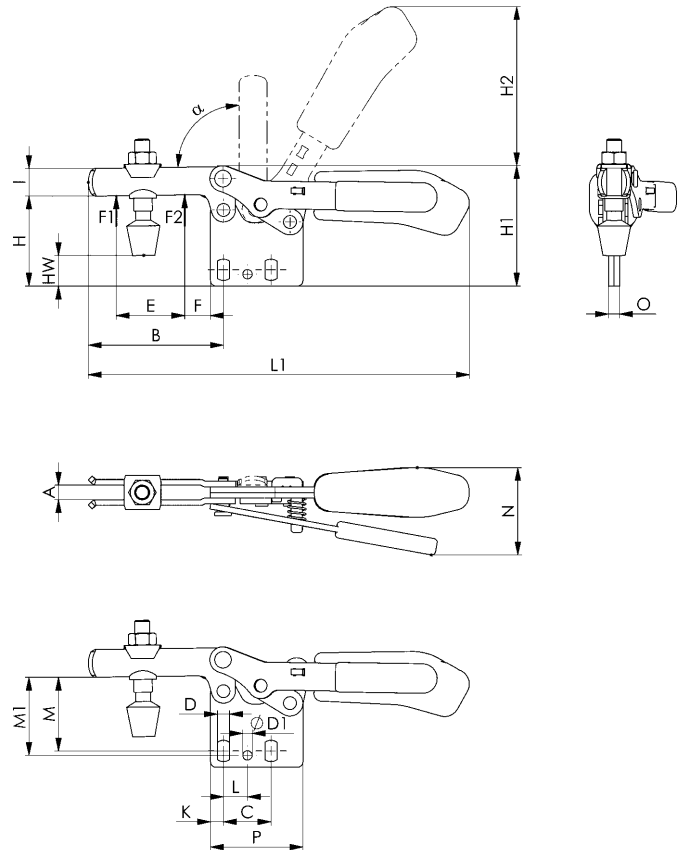

Recommendations



No. 6896,
page 171



No. 6890B,
page 165



No. 6835BS-2,
page 128

Dimensions:

Order no.	Size	A	B	C	D	D1	E	F	H	H1	H2	HW min.	HW max.	I	K	L	L1	M	M1	N	O	P	α
99648	3	8	73	25,7	6,5	5,1	37	14	49	65	86	9	22	15	7	13	206	38-42	42	47	6	50	90°



No. 6835BS-2

Horizontal toggle clamp with safety latch, black

For open and clamped positions. With open clamping arm and vertical, open base.

Matte black surface. Stainless steel rivets, which run in hardened bushes. Bearings are pre-lubricated.

Ergonomic, oil-resistant black handle with large grip surface and soft components. Lock washer for the thrust bolt at the end of the clamping arm.

Order no.	Size	F1 [kN]	F2 [kN]	Weight [g]
90712	2	1,0	1,2	230

Note:

These clamps are suitable for photogrammetric use. The matte-black surface of the clamps prevents reflection while photographing.

For suitable clamping arm extension see no. 6896.

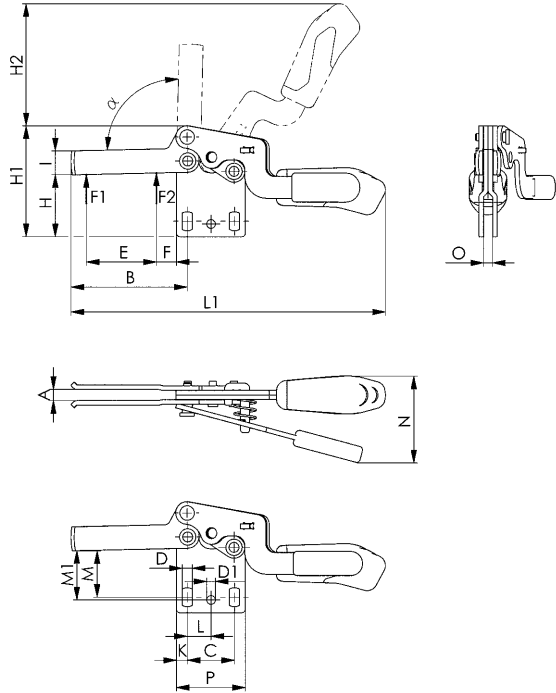

Recommendations



No. 6896,
page 171



No. 6890B,
page 165



No. 6832BS,
page 127

Dimensions:

Order no.	Size	A	B	C	D	D1	E	F	H	H1	H2	I	K	L	L1	M	M1	N	O	P	α
90712	2	6,2	64	26,0	5,6	4,8	38,6	11,0	34	61	67	13,2	6	13,1	173,5	23,0-28,0	27	48,0	5	38	90°

CAD



Subject to technical alterations.

No. 6835BO

Horizontal toggle clamp with open-holder, black

With open clamping arm and vertical, open base. Matt black surface. Stainless steel rivets, which run in hardened bearing bushes. Bearing positions are greased. Ergonomic, oil-resistant black handle with large grip surface and soft components. Retainer for the clamping screw on the clamp arm end.

Order no.	Size	F1 [kN]	F2 [kN]	Weight [g]
565863	2	1,0	1,2	195

Application:

This clamp can be loaded at the forward position on the clamping arm (F1) with an additional weight of up to 350 g without causing the open clamping arm to close again. The clamping arm remains open even if the clamp is installed in an inclined position.

This clamp is especially suitable for hard-to-reach areas, as an additional unlock mechanism does not have to be actuated.

Note:

These clamps are suitable for photogrammetric use. The matt-black surface of the clamps prevents reflection while photographing. For a suitable clamping arm extension, see no. 6896.

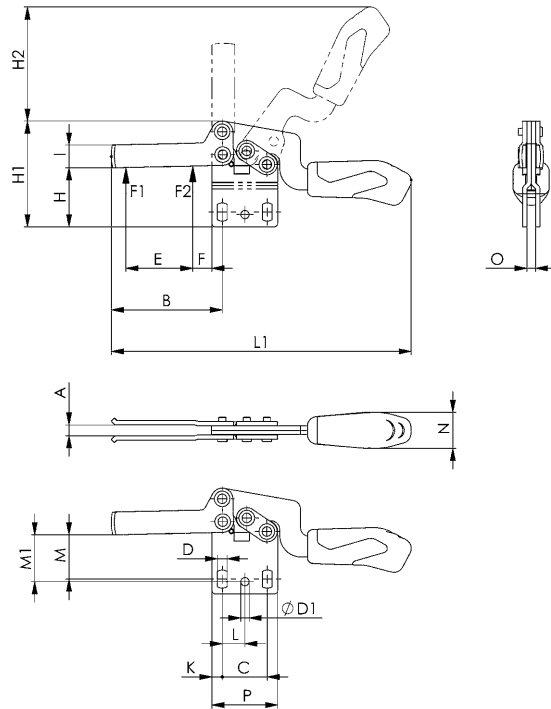

Recommendations



No. 6896,
page 171



No. 6890B,
page 165



No. 6835BS-2,
page 128

Dimensions:

Order no.	Size	A	B	C	D	D1	E	F	H	H1	H2	I	K	L	L1	M	M1	N	O	P	α
565863	2	6,2	64	26	5,6	4,8	38,6	11	34	61	67	13,2	6	13,1	173,5	23 - 28	27	21	5	38	90°



Subject to technical alterations.

No. 6835BS-3

Horizontal toggle clamp with safety latch, black

For open and clamped positions. With open clamping arm and vertical, open base.

Matte black surface. Stainless steel rivets, which run in hardened bushes. Bearings are pre-lubricated.

Ergonomic, oil-resistant black handle with large grip surface and soft components. Lock washer for the thrust bolt at the end of the clamping arm.

Order no.	Size	F1 [kN]	F2 [kN]	Weight [g]
90662	3	1,8	2,5	350

Note:

These clamps are suitable for photogrammetric use. The matte-black surface of the clamps prevents reflection while photographing.

For suitable clamping arm extension see no. 6896.

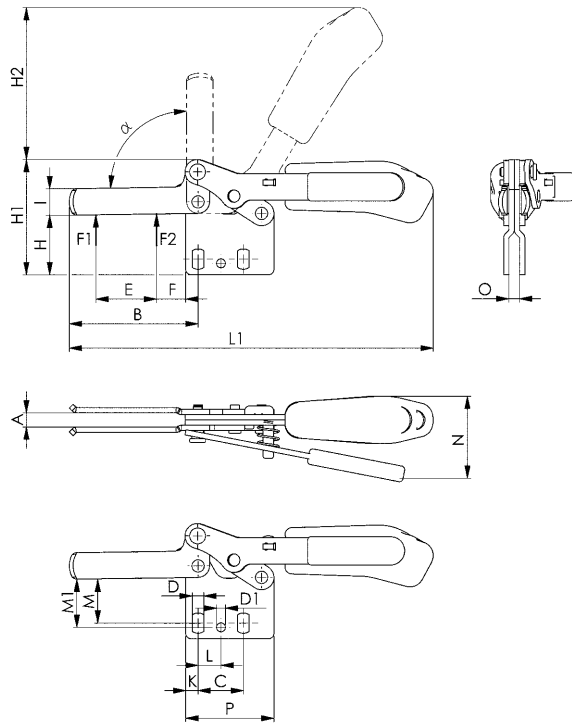

Recommendations



No. 6896,
page 171



No. 6890B,
page 165

Dimensions:

Order no.	Size	A	B	C	D	D1	E	F	H	H1	H2	I	K	L	L1	M	M1	N	O	P	α
90662	3	8,0	73	25,7	6,5	5,1	34,5	16,5	34	65	86	15,0	7	13,0	206,0	22,5-27,5	27	46,5	6	50	90°

CAD



Subject to technical alterations.

> AMF PNEUMATIC TOGGLE CLAMPS

have definite advantages over the manual toggle clamps:

- > relieve operator of strenuous clamping movement
- > a number of clamps can be used simultaneously
- > a number of clamps can be operated with different sequences
- > one or more clamps can be controlled from the machine panel
- > one or more clamps can be operated from different positions.

> ADVANTAGES OF THE TOGGLE ACTION...

- > in the event of air failure, clamp stays locked
- > low air consumption with maximum leverage
- > large opening angle, clearing the component for easy removal
- > assures maximum power-to-movement ratio.

> SELECTION GUIDE

The pneumatic toggle clamp no. 6820 correspond in design and dimensions to the mechanical toggle clamp no. 6800. Therefore hand operated clamps can be replaced with pneumatic toggle clamps - if required.

Heavy duty pneumatic toggle clamps no. 6825A/CE and no. 6826A are recommended to be incorporated in special and transfer machines. Tempered and ground bolts guarantee long life. The push type pneumatic toggle clamp no. 6850A corresponds in design and dimensions to the mechanical toggle clamp no. 6842 when pushed/closed, maximum forces of 2.5 - 10 kN can be reached.

> CLAMPING AND HOLDING FORCES

As already explained for the hand operated toggle clamps, the selection of the correct clamp is of utmost importance. To select the correct size of pneumatic clamp, apart from the holding force, the possible clamping force at 6 bar air pressure (other pressure media may also be used at pressures up to max. 10 bar) is indicated in the tables

- > F3 is the possible clamping force at the end of the arm.
- > F4 is the force applied at the fulcum.
- > F5 is the piston force 6 bar air pressure.

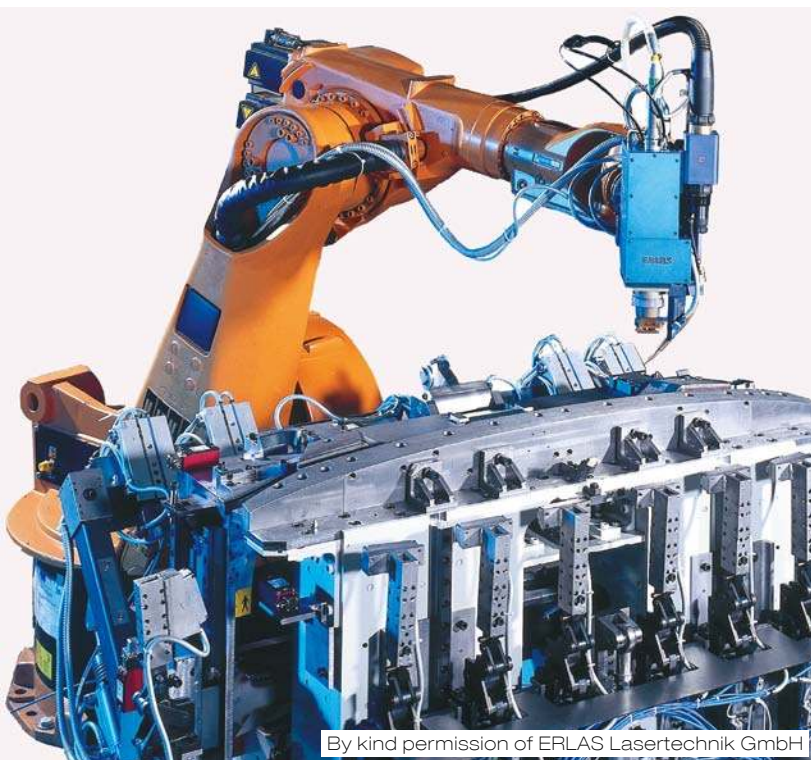

By kind permission of ERLAS Lasertechnik GmbH

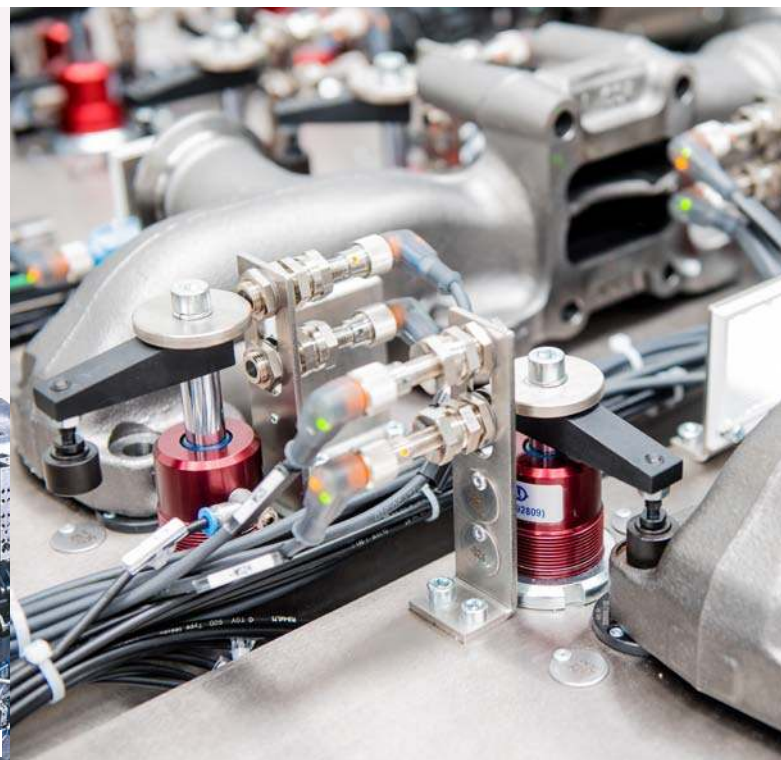

	PUSH TYPE PNEUMATIC TOGGLE CLAMP			COMBI-CLAMP			PNEUMATIC TOGGLE CLAMPS (VERTICAL CYLINDER)					
	6850A			6860P			6821A			6826A		
Size	3	5	7	1	2	3	2	3	4	4	6	8
Piston diameter [mm]	40	50	63	25	32	40	25	32	40	40	50	63
Max. holding force [kN]	4	10	25	1	2	3	1,2	2,5	3	9	18	30
Max. clamping force [kN]	2,5	5	10	0,3	0,5	0,7	1	1,1	2,2	2,2	3,5	6
Piston stroke [mm]	62	103	131	40	50	62	42	51	62	97	115	155
Service according to cycles	50.000											
Max. operating pressure [bar]	6	6	6	6	6	6	6	6	6	6	6	6
Air consumption [dm³] at 6 bar	0,14	0,37	0,78	0,26	0,35	0,8	0,26	0,35	0,8	1	1,6	1,8
Toggle joint	x	x	x	x	x	x	x	x	x	x	x	x
Sensing possibility	x	x	x	x	x	x	x	x	x	x	x	x

	LINK CLAMPS																		
	6829V					6829VA					6829L				6828LA				
Size	25	32	40	50	63	25	32	40	50	63	25	32	40	50	25	32	40	50	63
Piston diameter [mm]	25	32	40	50	63	25	32	40	50	63	25	32	40	50	25	32	40	50	63
Max. holding force [kN]	-	-	-	-	-	-	-	-	-	-	-	-	-	-	-	-	-	-	-
Max. clamping force [kN]	0,23	0,37	0,56	0,76	1,35	0,23	0,37	0,56	0,76	1,35	0,20	0,31	0,49	0,79	0,20	0,31	0,49	0,79	1,25
Piston stroke [mm]	22	28	30	30	30	22	28	30	30	30	32	36	41	47	33	37	42	48	48
Service according to cycles	500.000																		
Max. operating pressure [bar]	6	6	6	6	6	6	6	6	6	6	6	6	6	6	6	6	6	6	6
Air consumption [dm³] at 6 bar	0,02	0,04	0,07	0,11	0,18	0,02	0,04	0,07	0,11	0,18	0,03	0,05	0,1	0,17	0,03	0,05	0,1	0,17	0,29
Toggle joint	-	-	-	-	-	-	-	-	-	-	-	-	-	-	-	-	-	-	-
Sensing possibility	-	-	-	-	-	x	x	x	x	x	-	-	-	-	x	x	x	x	x

	SWING CLAMPS															
	6829KR/KL								6829BR/BL							
Size	12	16	20	25	32	40	50	63	12	16	20	25	32	40	50	63
Piston diameter [mm]	12	16	20	25	32	40	50	63	12	16	20	25	32	40	50	63
Max. holding force [kN]	-	-	-	-	-	-	-	-	-	-	-	-	-	-	-	-
Max. clamping force [kN]	0,03	0,06	0,08	0,17	0,27	0,45	0,7	1,1	0,03	0,06	0,08	0,17	0,27	0,45	0,7	1,1
Piston stroke [mm]	17,6	17,5	27	26	28	30	32	30	17,5	17,5	27	27	30	30	31	31
Service according to cycles	500.000															
Max. operating pressure [bar]	6	6	6	6	6	6	6	6	6	6	6	6	6	6	6	6
Air consumption [dm³] at 6 bar	0,003	0,007	0,011	0,022	0,04	0,07	0,116	0,178	0,003	0,007	0,011	0,023	0,044	0,07	0,112	0,184
Toggle joint	-	-	-	-	-	-	-	-	-	-	-	-	-	-	-	-
Sensing possibility	-	-	-	-	-	-	-	-	x	x	x	x	x	x	x	x

PNEUMATIC TOGGLE CLAMPS (HORIZONTAL CYLINDER)													
6820P				6820A				6825A			6825CE		
0	1	2	3	1	2	3	4	4	6	8	0	1	Size
10	12	20	25	16	25	32	40	40	50	63	16	20	Piston diameter [mm]
0,7	1,1	1,2	2,5	1,1	1,2	2,5	3	9	18	30	1	1,2	Max. holding force [kN]
0,09	0,18	0,5	1	0,3	1	1,1	2,2	2,2	3,5	6	0,4	0,8	Max. clamping force [kN]
40	40	40	50	32	42	51	62	97	115	155	40	40	Piston stroke [mm]
50.000												Service according to cycles	
6	6	6	6	6	6	6	6	6	6	6	6	6	Max. operating pressure [bar]
0,03	0,06	0,17	0,3	0,08	0,26	0,35	0,8	1	1,8	4,3	0,1	0,15	Air consumption [dm³] at 6 bar
x	x	x	x	x	x	x	x	x	x	x	x	x	Toggle joint
-	-	-	-	x	x	x	x	x	x	x	-	-	Sensing possibility

PNEUMATIC TOGGLE CLAMPS											
6828M				6828H			6828U				
10	16	20	25	16	20	25	40	50	63	Size	
10	16	20	25	16	20	25	32	40	50	Piston diameter [mm]	
Dependent on the clamping arm length (see diagrams)											Max. holding force [kN]
											Max. clamping force [kN]
8	25	54	75	25	54	75	380	800	1500	Max. holding torque [Nm]	
2,5	8	15	25	8	15	25	120	160	380	Max. clamping moment [Nm] at 5 bar	
see diagrams											Max. clamping arm length [mm]
3.000.000											Service according to ... cycles
6	6	6	6	6	6	6	6	6	6	Max. operating pressure [bar]	
0,03	0,06	0,11	0,2	0,06	0,11	0,2	0,72	1,26	2,25	Air consumption [dm³] at 6 bar	
x	x	x	x	x	x	x	x	x	x	Toggle joint	
-	x	x	x	x	x	x	x	x	x	Sensing possibility	

SWING CLAMPS													
6829ER/EL								6829W					
12	16	20	25	32	40	50	63	25	32	40	50	63	Size
12	16	20	25	32	40	50	63	25	32	40	50	63	Piston diameter [mm]
-	-	-	-	-	-	-	-	-	-	-	-	-	Max. holding force [kN]
0,03	0,06	0,08	0,17	0,27	0,45	0,7	1,1	0,2	0,3	0,6	0,9	1,4	Max. clamping force [kN]
17,6	17,5	27	26	29,5	30,5	30	29,5	19,5	25	25	39	39	Piston stroke [mm]
500.000												Service according to cycles	
6	6	6	6	6	6	6	6	6	6	6	6	6	Max. operating pressure [bar]
0,003	0,007	0,011	0,023	0,042	0,07	0,108	0,175	0,017	0,035	0,057	0,141	0,231	Air consumption [dm³] at 6 bar
-	-	-	-	-	-	-	-	-	-	-	-	-	Toggle joint
-	-	-	-	-	-	-	-	x	x	x	x	x	Sensing possibility

No. 6850A

Push type pneumatic toggle clamp

Push-type clamp.
Heavy version for long working life. Pneumatic cylinder with magnetic piston for end-position monitoring. Console galvanized and passivated, clamp body made of malleable iron casting, painted. Lever parts and push rod made of tempered steel, galvanized and passivated. Stainless steel rivets. Bearing positions are greased.

Complete with tempered, galvanised clamping screw no. 6880.



Order no.	Size	F1 [kN]	F3 [kN]	F5 [kN]	Vn [dm ³]	Clamping screw	Weight [g]
560007	3	4	2,5	0,75	0,14	M8 x 35	2610
560008	5	10	5,0	1,00	0,37	M12 x 50	5265
560009	7	25	10,0	1,80	0,78	M12 x 50	6120

F3 = maximum clamping force at 6 bar.
Vn = Air consumption per double stroke in dm³ at 6 bar.

Note:

Sizes 5 and 7 are not to design, and have long consoles.
Suitable proximity switches for end-position monitoring are available using order no. 392241.
0.3 m PUR cable with M8 connector and rotatable knurled nuts.
Switching function: NOC. Output: PNP.

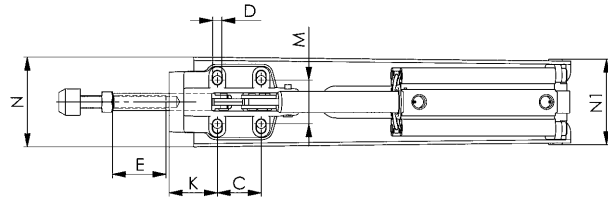
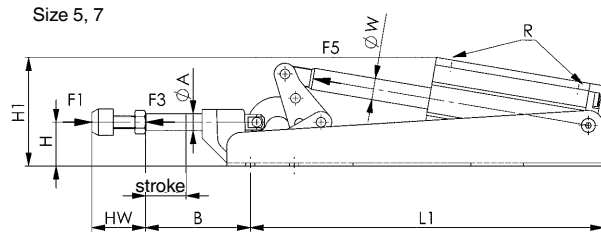
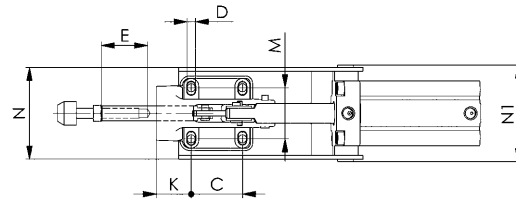
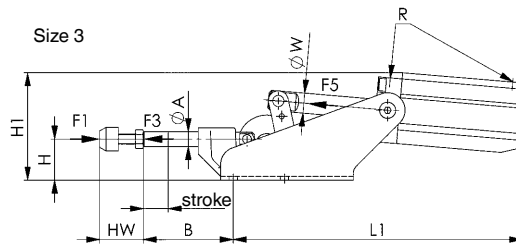

Recommendations



No. 6880,
page 166

Dimensions:

Order no.	Size	dia. A	B	C	D	E	H	H1	Stroke	HW min.	HW max.	K	L1	M	N	N1	R	dia. W	Piston dia.
560007	3	12	72	41	6,5	30	33	87	20,0	21,5	35	28	232	41	73,5	78	G1/8	16	40
560008	5	16	98	41	8,5	50	41	102	29,5	30,0	50	45	330	41	84,0	80	G1/4	20	50
560009	7	22	105	70	11,0	50	59	131	38,0	30,0	50	45	422	57	114,0	97	G1/4	20	63

Subject to technical alterations.

No. 6860P

Combi-clamp, pneumatic

Galvanized and passivated. Stainless steel rivets which run in case-hardened bearing bushes. Bearing points greased.

Equipped with pneumatic cylinder, double-acting, red anodised.

With magnetic piston for limit position query.



CAD

Order no.	Size	F1 [kN]	F2 [kN]	F3 [kN]	F4 [kN]	F5 [kN]	Vn [dm ³]	Weight [g]
90787	1	1,0	1,0	0,3	0,12	0,26	0,26	770
91488	2	2,0	2,0	0,5	0,25	0,35	0,35	1450
92163	3	3,0	3,0	0,7	0,35	0,80	0,80	3050

F3 or F4 = max. achievable clamping force at 6 bar.

Vn = air consumption per double stroke in dm³ at 6 bar.

Note:

Suitable proximity switches for end-position monitoring are available using order no. 392241.

0.3 m PUR cable with M8 connector and rotatable knurled nuts.

Switching function: NOC. Output: PNP.

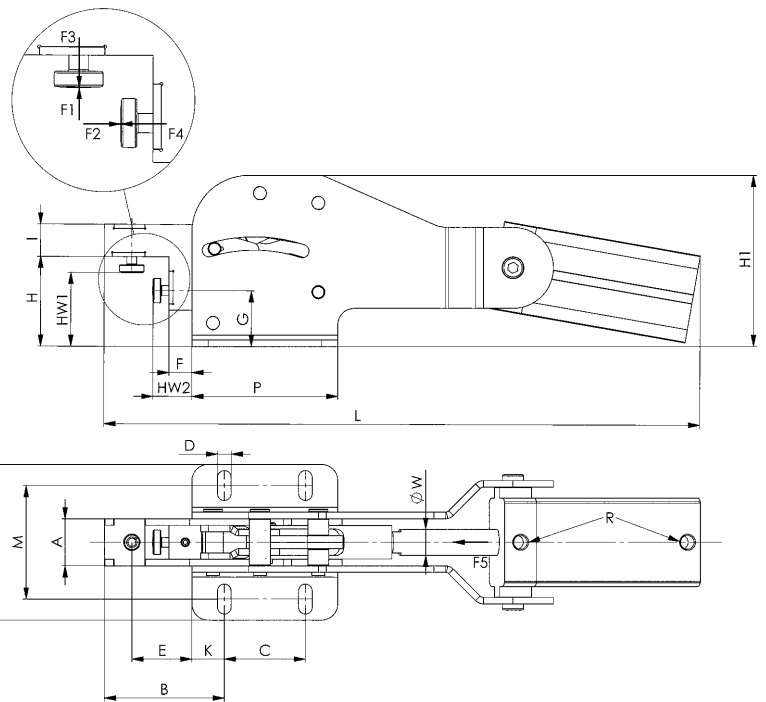

Recommendations



No. 6860,
page 44

Dimensions:

Order no.	Size	A	B	C	D	E	F	G	H	H1	HW1 min.	HW1 max.	HW2 min.	HW2 max.	I	K
90787	1	17,0	33	40	5,5	15	0,5	22	36,0	68	25,0	32,0	5	10	12	7,5
91488	2	19,5	56	50	6,5	32	9,0	28	46,0	87	31,5	40,5	14	22	16	12,5
92163	3	29,0	74	50	8,5	37	14,0	34	55,5	106	40,0	50,0	20	30	20	20,0

Order no.	Size	L	M	N	P	R	dia. W	Piston dia.
90787	1	225	34,5-39,5	51,5	55	M5	10	25
91488	2	309	50,0 - 62,5	76,0	75	G1/8	12	32
92163	3	368	61,5 - 81,5	98,0	90	G1/8	16	40

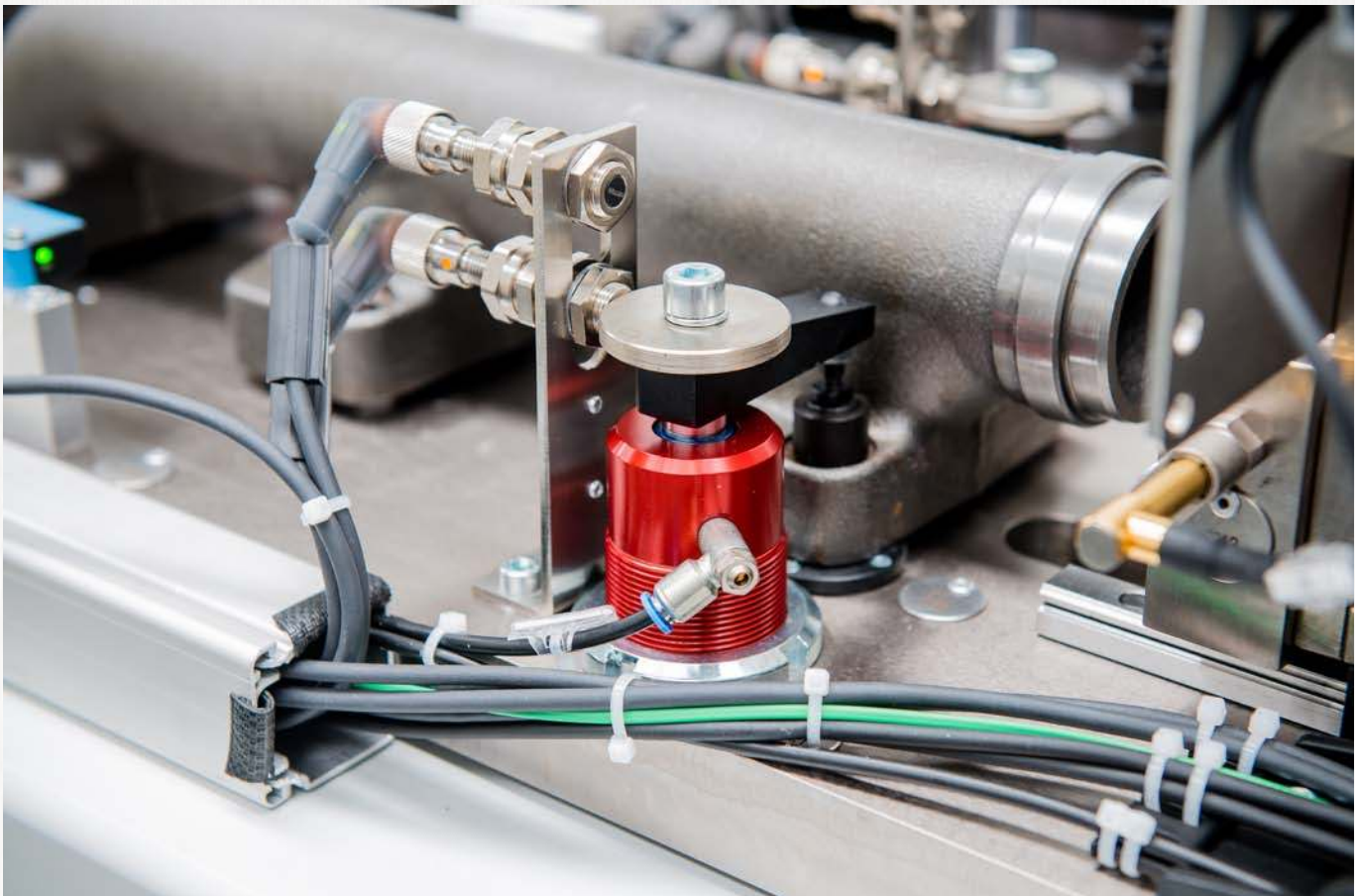
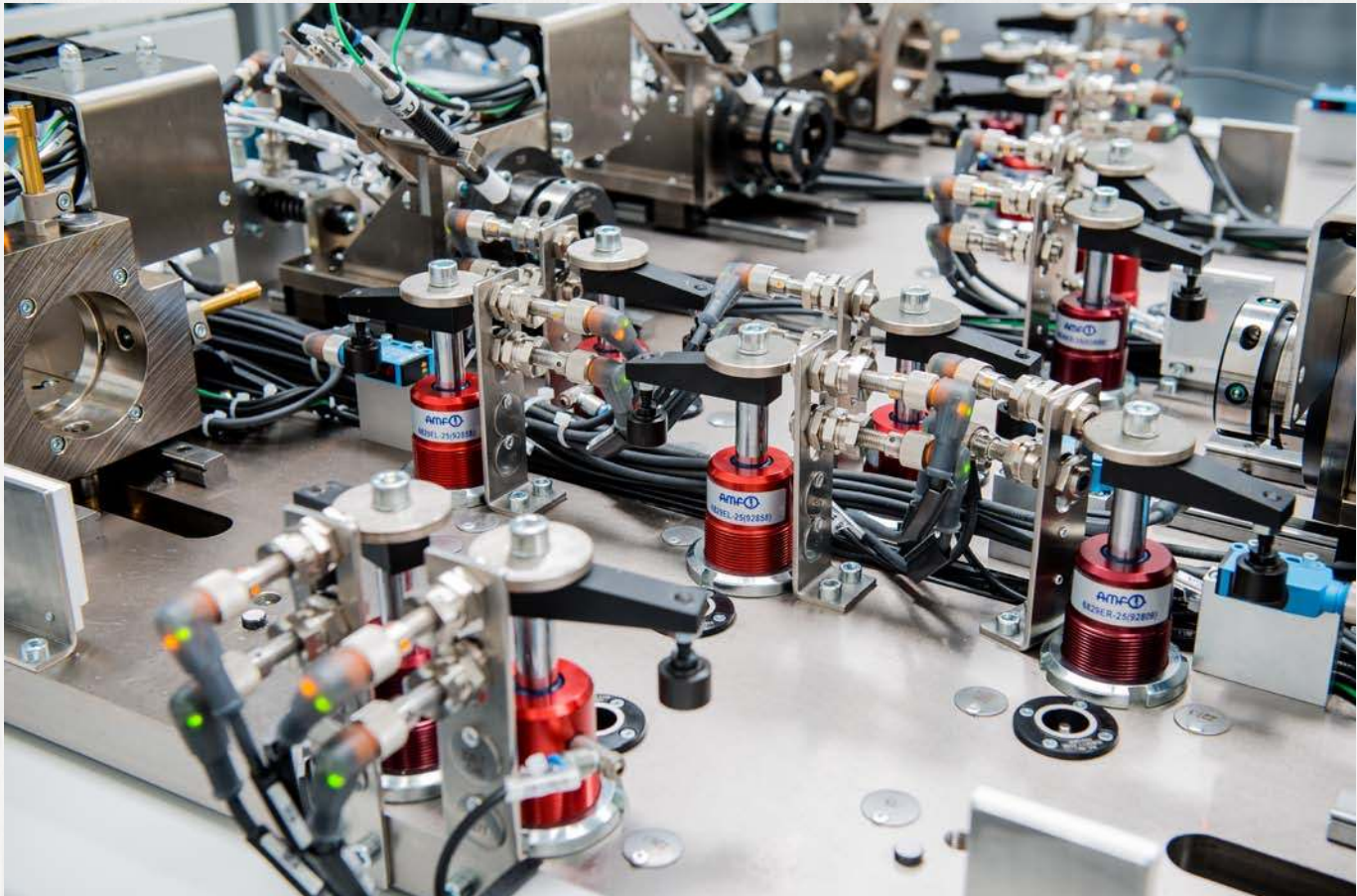

Subject to technical alterations.

No. 6820P

Pneumatic toggle clamp

With horizontal cylinder attachment.

Plastic pneumatic cylinder, double-acting and ready to connect. Clamps galvanized and passivated, rivets made of stainless steel, which, for sizes 2 and 3, run in hardened bearing bushes. Bearing positions are greased.

Complete with tempered, galvanised clamping screw no. 6890. The console is self-supporting and must be clear of other surfaces.



CAD

Order no.	Size	F1 [kN]	F2 [kN]	F3 [kN]	F4 [kN]	F5 [N]	Vn [dm ³]	Clamping screw	Weight [g]
559791	0	0,5	0,7	0,07	0,09	38	0,03	M4 x 25	125
559792	1	0,8	1,1	0,13	0,18	60	0,06	M5 x 30	400
559793	2	1,0	1,2	0,35	0,50	170	0,17	M6 x 35	600
559794	3	1,4	2,5	0,55	1,00	265	0,30	M8 x 45	800

F3 or. F4 = max. achievable clamping force at 6 bar.

Vn = air consumption per double stroke in dm³ at 6 bar.

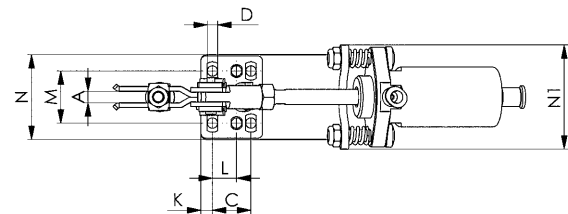
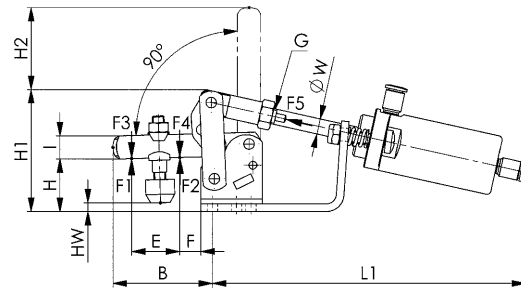
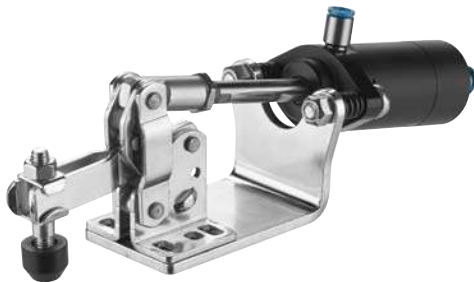

Recommendations



No. 6890,
page 164

Dimensions:

Order no.	Size	A	B	C	D	E	F	G	H	H1	H2	HW min.	HW max.	I	K
559791	0	4	31	13,5	4,5	14,5	5,0	M4	20,0	46	23,0	-0,5	5,5	8	5,0
559792	1	5	39	16,0	4,5	17,5	6,5	M6	21,5	50	34,5	-2	4,5	10	6,0
559793	2	6	52	20,0	5,4	20,0	16,0	M8	27,0	63	42,5	1	8	12	6,0
559794	3	8	78	20,0	7,5	37,0	19,0	M10 x 1,25	38,0	84	69,0	7	16	18	7,5

Order no.	Size	L	L1	M	N	N1	dia. W	Piston dia.	Outside-Ø for compressed air tubing
559791	0	-	131	23	33	29	4	10	4
559792	1	-	146	24	34	33	6	12	6
559793	2	12,5	163	27	44	54	8	20	6
559794	3	-	201	32	50	59	10	25	6

Subject to technical alterations.

No. 6820A

Pneumatic clamp

with horizontal cylinder attachment.
Fitted with pneumatic cylinder, double-acting. **With magnetic piston for end-position monitoring.** With throttle bores for reduced speed. Clamps are galvanised and passivated. Stainless steel rivets which, for sizes 2 to 4, run in hardened bearing bushes. Bearings positioned are lubricated.
Complete with tempered, galvanised clamping screw no. 6890.



CAD

Order no.	Size	F1 [kN]	F2 [kN]	F3 [kN]	F4 [kN]	F5 [kN]	Vn [dm ³]	Clamping screw	Weight [g]
555061	1	0,8	1,1	0,20	0,3	0,10	0,08	M5 x 30	320
555062	2	1,0	1,2	0,70	1,0	0,30	0,26	M6 x 35	600
555063	3	1,0	2,5	0,65	1,1	0,50	0,35	M8 x 45	1005
555064	4	2,0	3,0	1,50	2,2	0,75	0,80	M8 x 65	1520

F3 or F4 = max. achievable clamping force at 6 bar.
Vn = air consumption per double stroke in dm³ at 6 bar.

Note:

Suitable proximity switches for end-position monitoring are available using order no. 392241. 0.3 m PUR cable with M8 connector and rotatable knurled nuts.
Switching function: NOC. Output: PNP.

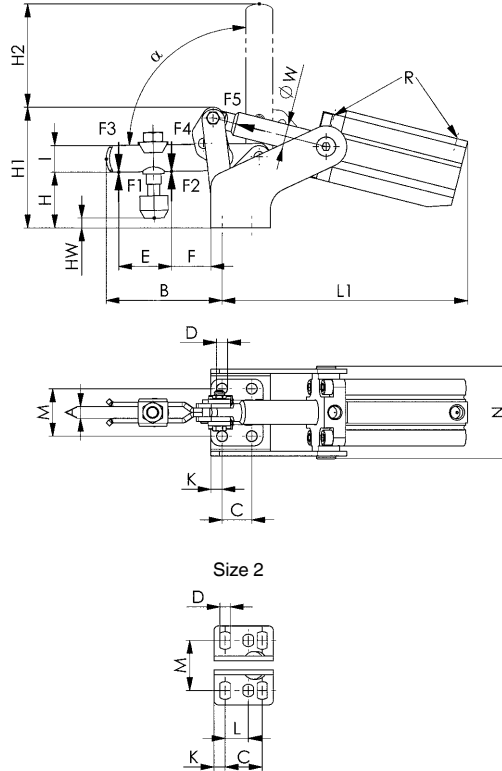

Recommendations



No. 6895,
page 178



No. 6821A,
page 139

Dimensions:

Order no.	Size	A	B	C	D	E	F	H	H1	H2	HW min.	HW max.	I	K	L	L1	M	N	R	dia. W	Piston dia.	Opening angle α
555061	1	5	39,5	16	4,5	18,0	6	21,5	51,0	34,0	-2,0	4,5	10	6,0	-	126,0	24	50,0	M5	8	16	92,0°
555062	2	6	52,0	20	5,5	25,0	11	26,0	62,0	42,5	-1,0	7,0	12	6,0	12,5	145,0	27	54,5	M5	12	25	91,5°
555063	3	8	78,0	20	7,5	35,5	19	36,5	82,0	69,0	5,4	14,0	18	7,5	-	165,5	32	62,5	G1/8	16	32	90,0°
555064	4	10	100,5	32	8,5	45,5	25	45,5	99,5	91,5	-3,0	25,5	20	13,0	-	196,0	45	77,5	G1/8	16	40	90,5°

No. 6821A

Pneumatic clamp

with vertical cylinder structure.
 Space-saving angled form. Vertical or horizontal mounting.
 Fitted with pneumatic cylinder, double-acting. **With magnetic piston for end-position monitoring.** With throttle bores for reduced speed. Clamps are galvanised and passivated.
 Stainless steel rivets, which run in hardened bearing bushes.
 Bearings positioned are lubricated.
Complete with tempered, galvanised clamping screw no. 6890.



Order no.	Size	F1 [kN]	F2 [kN]	F3 [kN]	F4 [kN]	F5 [kN]	Vn [dm ³]	Clamping screw	Weight [g]
555065	2	1	1,2	0,70	1,0	0,30	0,26	M6 x 35	625
555066	3	1	2,5	0,65	1,1	0,50	0,35	M8 x 45	1025
555067	4	2	3,0	1,50	2,2	0,75	0,80	M8 x 65	1700

F3 or F4 = max. achievable clamping force at 6 bar.
 Vn = air consumption per double stroke in dm³ at 6 bar.

Note:

Suitable proximity switches for end-position monitoring are available using order no. 392241. 0.3 m PUR cable with M8 connector and rotatable knurled nuts.
 Switching function: NOC. Output: PNP.

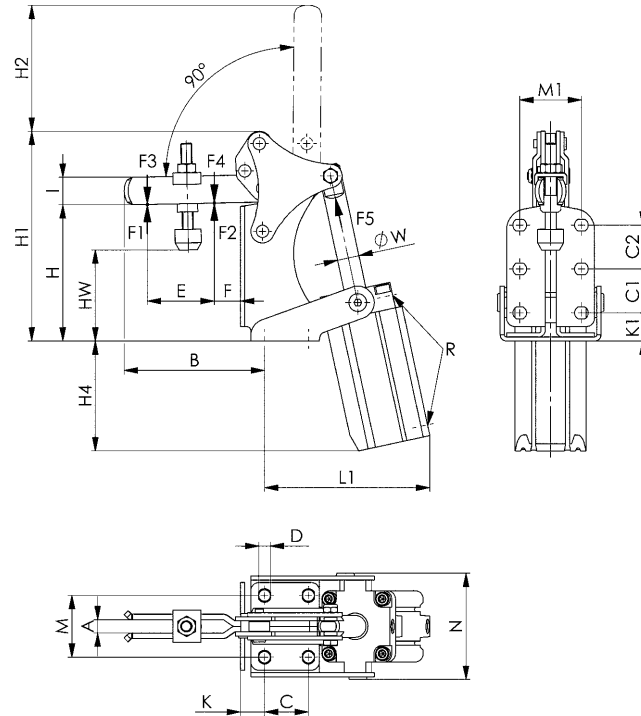

Recommendations



No. 6895,
page 178



No. 6829V,
page 144



No. 6826A,
page 142

Dimensions:

Order no.	Size	A	B	C	C1	C2	D	E	F	H	H1	H2	H4	HW min.	HW max.	I	K	K1	L1	M	M1	N	R	dia. W	Piston dia.
555065	2	6,0	56,5	12,5	12,5	12,5	5,6	25	6,5	65,0	100,5	43	67,5	38,4	46,0	12	15,3	15,9	78	27	26,6	54,5	M5	12	25
555066	3	8,0	80,5	16,0	16,0	-	6,5	36	12,5	68,5	114,5	69	78,0	38,0	46,5	18	16,5	17,5	96	25	25,0	62,5	G1/8	16	32
555067	4	9,7	102,0	32,0	32,0	32,0	8,5	49	19,0	99,5	153,0	92	80,0	51,0	79,5	20	17,5	20,5	121	45	45,0	77,5	G1/8	16	40

No. 6825A

Heavy pneumatic toggle clamp

With horizontal cylinder attachment.
Tempered steel, burnished. The bearing bolts running in bearing bushes are tempered, ground and locked with circlips.
With magnetic piston for end-position monitoring.
Ready to connect, comprising:
- mechanical element
- double acting pneumatic cylinder



CAD

Order no.	Size	F1 [kN]	F2 [kN]	F3 [kN]	F4 [kN]	F5 [kN]	Vn [dm ³]	Weight [g]
559769	4	6	9	1,5	2,2	0,75	1,0	4800
559770	6	12	18	2,5	3,5	1,00	1,8	6965
559771	8	20	30	4,0	6,0	1,80	4,3	12785

F3 or F4 = max. achievable clamping force at 6 bar.
Vn = air consumption per double stroke in dm³ at 6 bar.

Application:

These pneumatic toggle clamps are of machine tool quality and can be installed in machines such as material handling lines and special machines. Opening and clamping position of the clamp can be controlled electrically and can be intergrated into automated manufacturing.

Note:

This heavy pneumatic toggle clamp is also available in a hydraulicdrive version (article no. 6960C). In case of interest, please ask for our catalogue „Hydraulic Clamping Systems“. Suitable proximity switches for end-position monitoring are available using order no. 392241. Design: PUR cable 0.3 m with M8 plug connection and rotating knurled nuts. Switching function: NOC. Output: PNP.

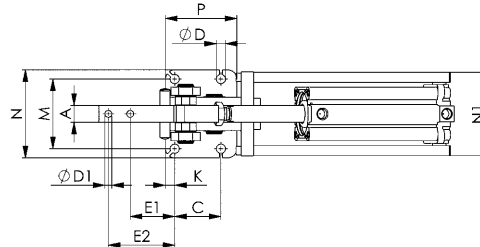
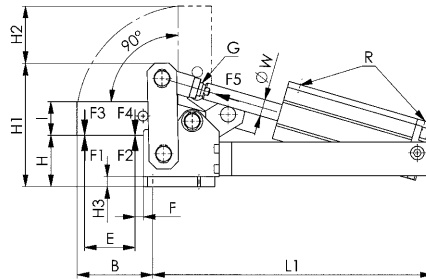
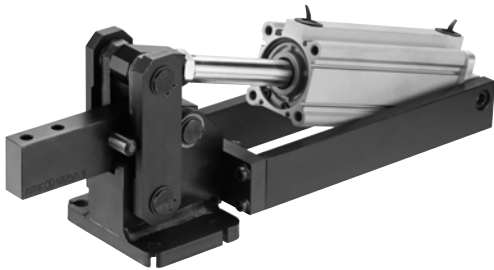

Recommendations



No. 6885,
page 167



No. 6825CE,
page 141



No. 6828M,
page 148

Dimensions:

Order no.	Size	A	B	C	dia. D	dia. D1	E	E1	E2	F	G	H	H1	H2	H3
559769	4	15	82	52	11	6,2	54	47,0	74,0	10,0	M12 x 1,25	57	122	75	12
559770	6	20	90	55	11	8,2	60	53,0	79,0	10,0	M16 x 1,50	61	147	68	12
559771	8	30	128	80	13	13,0	95	69,5	109,5	9,5	M16 x 1,50	86	196	110	12

Order no.	Size	I	K	L1	M	N	N1	P	R	dia. W	Piston dia.
559769	4	30	10,0	292,5	70	90	82	77,0	G1/8	16	40
559770	6	40	11,0	333,0	83	105	100	85,0	G1/4	20	50
559771	8	60	12,5	404,0	111	136	123	112,5	G1/4	20	63

Subject to technical alterations.

No. 6825CE

Heavy pneumatic toggle clamp

with horizontal cylinder attachment.

With adjustable end position cushioning.

Magnetic piston for end-position monitoring. Tempered steel, blued. The axle bolts running in bronze bushes are tempered, ground and locked with circlips.

Clamp is ready for installation and consists of:

- toggle clamp element
- double acting FESTO pneumatic cylinder
- bearing block

These cylinders are made to DIN ISO 6432.



CAD

Order no.	Size	F1 [kN]	F2 [kN]	F3 [kN]	F4 [kN]	F5 [kN]	Vn [dm ³]	Weight [g]
92106	0	0,6	1,0	0,2	0,4	0,10	0,10	260
92122	1	0,8	1,2	0,6	0,8	0,19	0,15	500

F3 or. F4 = max. achievable clamping force at 6 bar.

Vn = air consumption per double stroke in dm³ at 6 bar.

Application:

These pneumatic toggle clamps are of machine tool quality and can be installed in machines such as material handling lines and special machines. Opening and clamping position of the clamp can be controlled electrically and can be intergrated into automated manufacturing.

Note:

Please enquire separately for suitable fastening kits and proximity switches for end position monitoring.

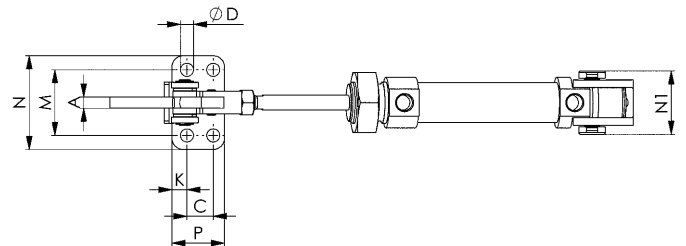
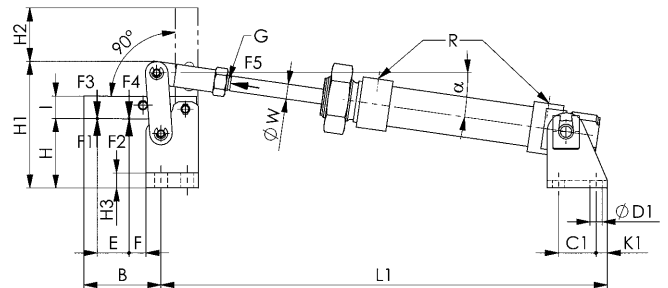

Recommendations



No. 6825A,
page 140



No. 6828U,
page 152



No. 6826A,
page 142

Dimensions:

Order no.	Size	A	B	C	C1	dia. D	dia. D1	E	F	G	H	H1	H2	H3
92106	0	5	33,5	11	15	4,5	5,5	14	8,5	M6	26	53	23,0	6
92122	1	6	41,0	14	20	7,0	6,6	17	9,0	M8	37	68	28,5	8

Order no.	Size	I	K	K1	L1	M	N	N1	P	R	dia. W	α	Piston dia.	Piston stroke
92106	0	10	5,5	5	195	27	35	27,5	22	M5	6	6,6°	16	40
92122	1	12	8,0	6	238	35	50	34,0	28	G1/8	8	8,2°	20	40

Piston dia. = Cylinder dia. required for piston force F5 at 6 bar air pressure.

No. 6826A

Heavy pneumatic toggle clamp

with vertical cylinder attachment.

Tempered steel, burnished. The bearing bolts running in bearing bushes are tempered, ground and locked with circlips.

With magnetic piston for end-position monitoring.

Ready to connect, comprising:

- mechanical element
- double acting pneumatic cylinder



Order no.	Size	F1 [kN]	F2 [kN]	F3 [kN]	F4 [kN]	F5 [kN]	Vn [dm ³]	Weight [g]
559772	4	6	9	1,5	2,2	0,75	1,0	3850
559773	6	12	18	2,5	3,5	1,00	1,6	6950
559774	8	20	30	4,0	6,0	1,80	1,8	13160

F3 or F4 = max. achievable clamping force at 6 bar.

Vn = air consumption per double stroke in dm³ at 6 bar.

Application:

These pneumatic toggle clamps are of machine tool quality and can be installed in machines such as material handling lines and special machines. Opening and clamping position of the clamp can be controlled electrically and can be integrated into automated manufacturing.

Note:

Suitable proximity switches for end-position monitoring are available using order no. 392241.

Design: PUR cable 0.3 m with M8 plug connection and rotating knurled nuts.

Switching function: NOC.

Output: PNP.

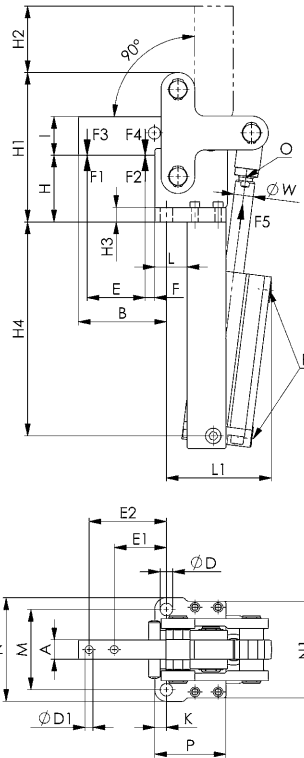

Dimensions:

Order no.	Size	A	B	dia. D	dia. D1	E	E1	E2	F	H	H1	H2	H3	H4
559772	4	15	82	11	6,2	54	47	74	10,0	65	129,5	75,5	12	193
559773	6	20	91	13	8,2	60	54	80	10,0	69	154,5	68,5	15	221
559774	8	30	125	17	13,0	95	67	107	9,5	94	204,0	110,0	20	255

Order no.	Size	I	K	L	L1	M	N	N1	O	P	R	dia. W	Piston dia.
559772	4	30	10	37,0	94	70	90	82	M12 x 1,25	67,0	G1/8	16	40
559773	6	40	12	33,5	109	83	107	100	M16 x 1,50	73,5	G1/4	20	50
559774	8	60	15	49,0	147	115	145	123	M16 x 1,50	109,0	G1/4	20	63

Subject to technical alterations.



No. 6829V

Link Clamp, pneumatic, flange version

dual acting.

Parts of mechanism are made of steel and blued. Piston rod non-rusting, polished. Body is made of aluminium, anodised. HART-COAT® surface for wear-resistance.

Complete with clamping screw.

Attachment options:

- from above by cylinder screws through the flange
- screwed in using the threads and secured with lock nut
- both ends secured with lock nuts

Accessories (not supplied as standard):

- lock nut no. 6829N
- clamping screw no. 6880



CAD



Order no.	Size	F3 [kN]	Clamping screw	Weight [g]
93609	25	0,23	M 6x25	580
93617	32	0,37	M 8x35	950
93625	40	0,56	M 8x35	1200
93633	50	0,76	M12x50	1900
93641	63	1,35	M12x50	2300

F3 = at 6 bar max. air pressure

Note:

The lever mechanism can be dismantled so that it can be individually modified. The mounting holes in the flange are similar to those in threaded flange No. 6829GF. Operate only with lubricated air.

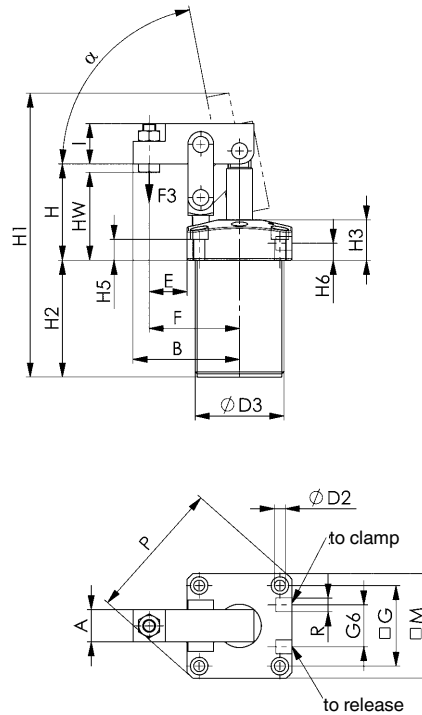

Examples of mountings

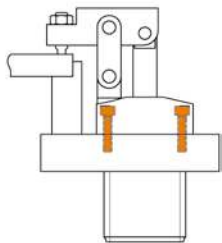

From above with 4 socket cap screws through the flange.

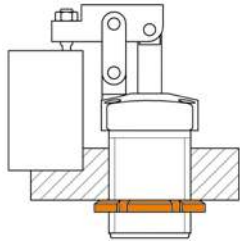

By screwing the body into a tapped hole and locking with a grooved nut.

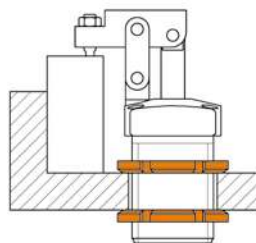

By inserting the body into a plain hole and locking with two grooved nuts.

Recommendations



No. 6829N,
page 160



No. 6880,
page 166



No. 6828M,
page 148

Dimensions:

Order no.	Size	A	B	dia. D2	dia. D3	E	F	G	G6	H	H1	H2	H3	H5	H6	HW	I	M	P	R	Piston dia.	α
93609	25	16	48,0	5,5	M40x1,5	16,0	41,0	37	23	51,0	144	62	25	15	12,0	37-47	17	50	66	M5	25	79°
93617	32	18	60,0	6,5	M50x1,5	22,0	52,0	45	23	57,0	170	73	25	13	10,5	50-56	20	60	80	G1/8	32	80°
93625	40	20	66,0	6,8	M55x1,5	23,5	56,0	50	26	60,0	178	73	25	13	10,5	50-54,5	25	65	87	G1/8	40	79°
93633	50	22	77,5	8,5	M65x1,5	26,0	63,5	58	32	65,0	200	79	25	11	10,5	47-57	30	75	100	G1/8	50	72°
93641	63	22	88,0	8,5	M80x1,5	29,5	74,0	70	35	71,5	211	80	25	11	9,0	54-64	30	89	118	G1/8	63	63°

Subject to technical alterations.

No. 6829VA

Link clamp, pneumatic, flange version

Double-acting with sensor groove and magnetic piston for end-position monitoring.

Steel mechanical parts, burnished. Piston rod non-rusting, polished. Body is made of aluminium, red anodised. HART-COAT® surface for wear-resistance.

Complete with clamping screw.



CAD



Order no.	Size	F3 [kN]	Clamping screw	Weight [g]
562505	25	0,23	M6 x 25	580
562506	32	0,37	M8 x 35	950
562507	40	0,56	M8 x 35	1200
562508	50	0,76	M12 x 50	1900
562509	63	1,35	M12 x 50	2300

F3 = at 6 bar max. permissible operating pressure

Note:

The lever mechanism can be dismantled so that it can be individually modified.
Can only be operated with oiled air.

Suitable proximity switches for end-position monitoring are available using order no. 392241.

Version: PUR cable 0.3 m with M8 plug connection and rotatable knurled nuts.

Switching function: NOC.

Output: PNP.

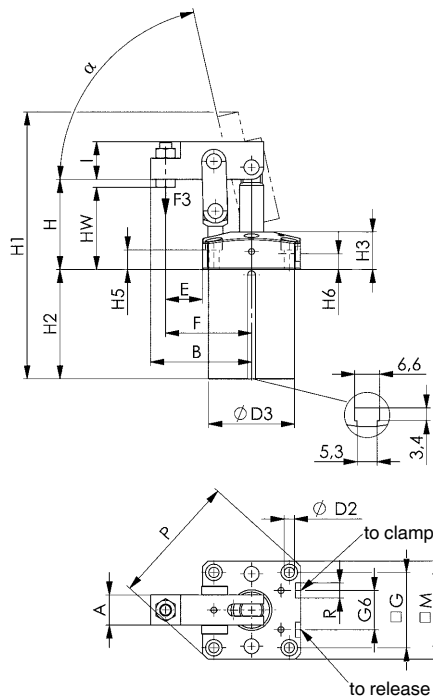

Example of mounting:

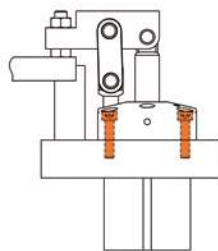

From above with 4 socket cap screws through the flange.

Recommendations



No. 6820SIS,
page 178



No. 6829BR/BL,
page 156



No. 6828M,
page 148

Dimensions:

Order no.	Size	A	B	dia. D2	dia. D3	E	F	G	G6	H	H1	H2	H3	H5	H6	HW	I	M	P	R	Piston dia.	α
562505	25	16	48,0	5,5	42	16,0	41,0	37	23	51	144	62	25	15	12,0	37,0 - 47,0	17	50	66	M5	25	79°
562506	32	18	60,0	6,5	52	22,0	52,0	45	23	57	170	73	25	13	10,5	50,0 - 56,0	20	60	80	G1/8	32	80°
562507	40	20	67,0	6,8	57	24,5	57,0	50	26	60	177	73	25	13	10,5	50,0 - 54,5	25	65	87	G1/8	40	77°
562508	50	22	77,5	8,5	67	26,0	63,5	58	32	65	200	79	25	11	10,5	47,0 - 57,0	30	75	100	G1/8	50	72°
562509	63	22	88,0	8,5	82	29,5	74,0	70	35	67	204	80	25	11	9,0	50,0 - 58,0	30	89	118	G1/8	63	53°

Subject to technical alterations.

No. 6829L

Link clamp, pneumatic, flange version

With lowerable clamp arm.

Double-acting. Parts of mechanism are made of steel and burnished. Piston rod non-rusting, polished. Body is made of aluminium, red anodised. HART-COAT® surface for wear-resistance. Operating temperature 0 - 60 °C.

Order no.	Size	F3		Weight [g]
			[kN]	
565859	25		0,20	800
565860	32		0,31	1200
565861	40		0,49	2000
565862	50		0,79	2900

F3 = at 6 bar max. permissible operating pressure

Application:

The special kinematics of the link clamp permits use in restricted spaces, such as clamping pockets or clamping slots.

In the opened state, the link clamp is very flat and so permits loading and unloading of the workpieces without disturbing contours.

Use is possible even in a material handling line, as workpieces or trays can be transported further collision-free without lifting.

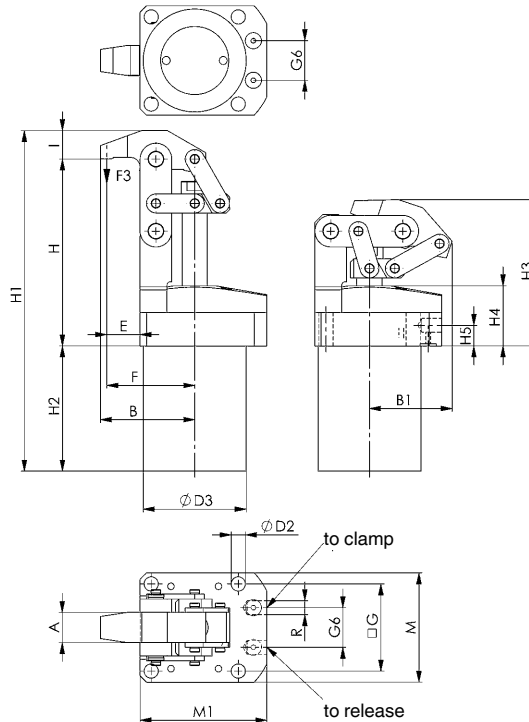

Example of mounting:

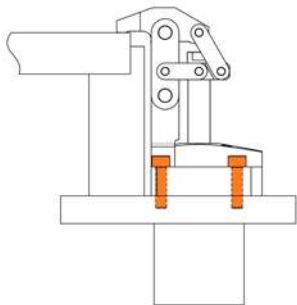

From above with 4 socket cap screws through the flange.

Application examples:

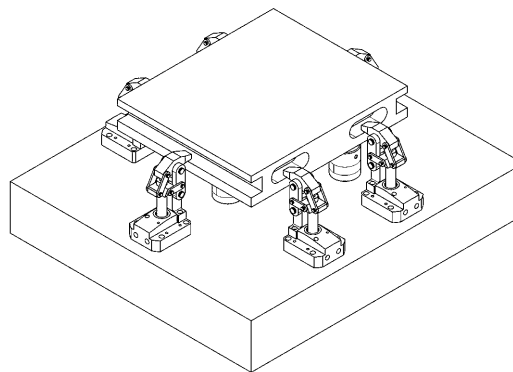
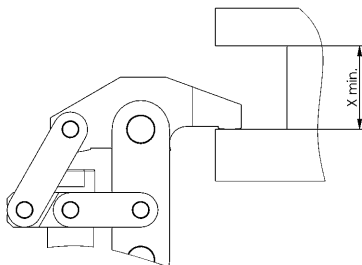

Recommendations



No. 6829V,
page 144



No. 6829VA,
page 145



No. 6828M,
page 148

Dimensions:

Order no.	Size	A	B	B1	dia. D2	dia. D3	E	F	G	G6	H	H1	H2	H3	H4	H5	I	M	M1	R	Piston dia.	X min.
565859	25	12	46,0	37,0	5,5	47	17	42,0	40	21	88,5	161	59	71,0	31	12,5	13	50	60	G1/8	25	17
565860	32	16	53,5	40,4	6,6	55	20	49,5	47	21	95,5	181	70	78,2	31	12,5	15	59	67	G1/8	32	25
565861	40	19	59,5	52,1	9,0	65	21	55,5	55	25	118,0	215	79	92,4	38	13,0	18	69	80	G1/4	40	25
565862	50	22	71,0	57,0	11,0	70	25	67,0	67	28	133,0	241	86	107,5	44	15,0	22	84	93	G1/4	50	35

Subject to technical alterations.

No. 6829LA

Link clamp, pneumatic, flange version

With clamp arm, which can be lowered sensor groove and magnetic piston for end-position monitoring.

Double-acting. Parts of mechanism are made of steel and burnished.

Piston rod non-rusting, polished.

Body is made of aluminium, red anodised. HART-COAT® surface for wear-resistance.

Operating temperature 0 - 60 °C.



Order no.	Size	F3		Weight [g]
			[kN]	
569830	25		0,20	800
569831	32		0,31	1200
569832	40		0,49	2000
569833	50		0,79	2900
569834	63		1,25	3500

F3 = at 6 bar max. permissible operating pressure

Application:

The special kinematics of the link clamp permits use in restricted spaces, such e.g. in clamping pockets or clamping slots.

In the opened state, the link clamp is very flat and so permits loading and unloading of the workpieces without disturbing contours.

Use is possible even in a material handling line, as workpieces or trays can be transported further collision-free without lifting.

Note:

Suitable proximity switches for end-position monitoring are available using order no. 392241.

Version: PUR cable 0.3 m with M8 plug connection and rotatable knurled nuts.

Switching function: NOC. Output: PNP.

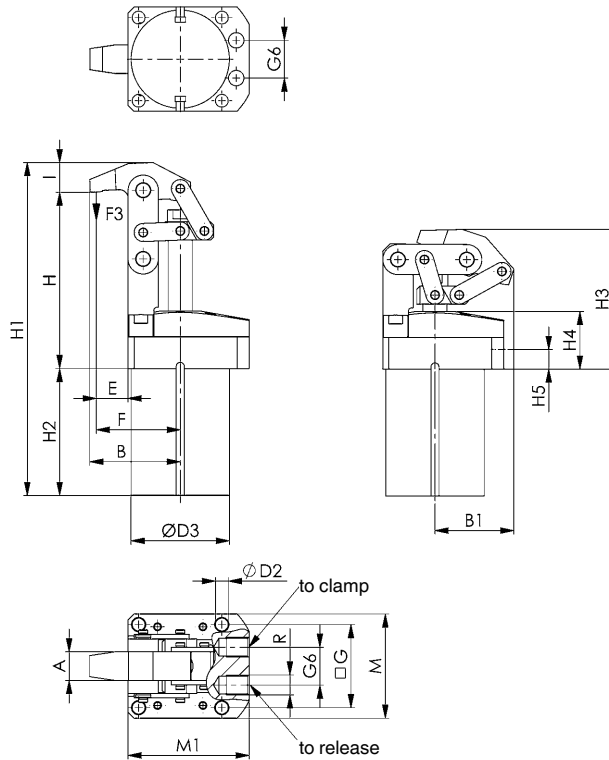

Recommendations



No. 6829V,
page 144



No. 6829VA,
page 145



No. 6828M,
page 148

Dimensions:

Order no.	Size	A	B	B1	dia. D2	dia. D3	E	F	G	G6	H	H1	H2	H3	H4	H5	I	M	M1	R	Piston dia.	X min.
569830	25	12	46,3	37,0	5,5	47	17	42,0	40	21	87,3	169,0	67	72,4	31	11,5	13	50	60	G1/8	25	17
569831	32	16	53,7	40,4	6,5	55	20	49,5	47	21	94,2	186,0	75	78,2	31	12,5	15	59	67	G1/8	32	25
569832	40	19	59,8	52,2	8,5	65	21	55,4	55	25	116,7	220,3	84	92,4	38	13,0	18	69	80	G1/4	40	25
569833	50	22	71,3	57,0	10,5	70	25	67,0	67	28	131,7	246,3	91	107,5	44	15,5	22	84	93	G1/4	50	35
569834	63	22	71,3	57,0	10,5	85	23	67,0	72	28	131,7	246,3	91	107,5	44	16,0	22	88	98	G1/4	63	35

Subject to technical alterations.

No. 6828M

Pneumatic toggle clamp

Double-acting.

Max. operating pressure 6 bar.

Mini design in block version for clamping and gripping technology.

High-strength aluminium housing, anodised.

Size 16, 20 and 25 with magnetic piston for end-position monitoring. Clamp arm made from steel, bronzed, with three holes.

Order no.	Size	Clamping moment at 5 bar	Holding moment max.	Weight
		[Nm]	[Nm]	[g]
567170	10	2,5	8	100
91843	16	8,0	25	300
91868	20	15,0	54	550
91884	25	25,0	75	850

Note:

Suitable proximity switches for end-position monitoring are available using order no. 392241.

0.3 m PUR cable with M8 connector and rotatable knurled nuts.

Switching function: NOC. Output: PNP.



Größe / size 16, 20, 25

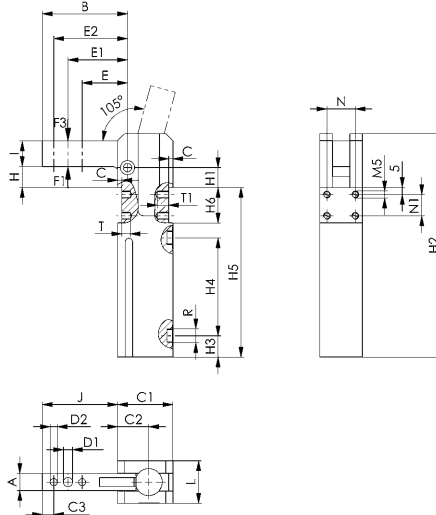

Application example:

Mini clamp, e.g. as „cover close device“. Defined, locked close position through toggle lever mechanism.

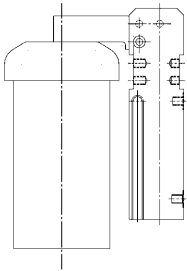

Größe / size 10

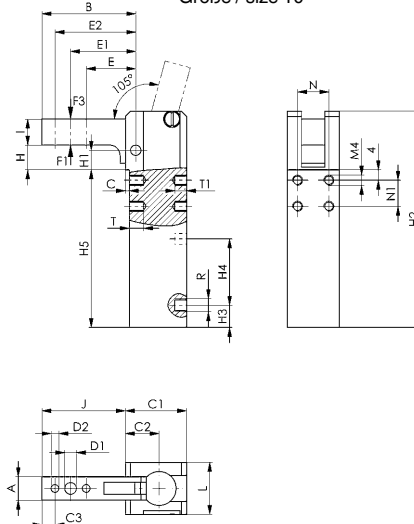

Recommendations



No. 6829V,
page 144



No. 6829L,
page 146



No. 6828U,
page 152

CAD



Dimensions:

Order no.	Size	A	B	C	C1	C2	C3	D1	D2 H7	E	E1	E2	H	H1	H2
567170	10	9	36	1,5	23,5	13	5	4,5	3	19	25,0	31	9,5	7,5	83
91843	16	10	50	2,5	32,0	18	6	5,5	4	28	36,0	44	7,5	7,5	123
91868	20	12	60	3,0	39,0	22	8	6,5	5	32	42,0	52	15,0	14,0	158
91884	25	16	75	4,0	45,0	25	10	8,5	6	40	52,5	65	19,0	17,0	182

Order no.	Size	H3	H4	H5	H6 +0.1	I	J	L	N ±0.1	N1 ±0.1	R	T	T1	Piston dia.
567170	10	8,5	25,5	60,5	-	10	32	20	12	10	M5	5,5	4,5	10
91843	16	12,0	57,0	96,0	20	15	44	26	16	10	M5	7,0	5,0	16
91868	20	15,0	69,0	120,0	25	18	53	30	20	15	G1/8	8,0	6,0	20
91884	25	17,5	80,0	136,0	28	22	68	35	25	18	G1/8	8,0	6,0	25

Subject to technical alterations.

No. 6828H

Pneumatic clamp with lever

double-acting and with additional lever for manual opening and/or closing.

Max. operating pressure 6 bar.

Mini design in block version for clamping and gripping technology. High-strength aluminium, red anodised. **Magnetic piston for end-position monitoring.** Clamp arm made from steel, bronzed, with three bores.



Order no.	Size	Clamping moment at 5 bar [Nm]	Lever left	Lever right	Holding moment max. [Nm]	Weight [g]
555083	16	8	-	●	25	320
555170	16	8	●	-	25	320
555084	20	15	-	●	54	700
555171	20	15	●	-	54	700
555085	25	25	-	●	75	920
555172	25	25	●	-	75	920

Note:

Suitable proximity switches for end-position monitoring are available using order no. 392241. 0.3 m PUR cable with M8 connector and rotatable knurled nuts. Switching function: NOC. Output: PNP.

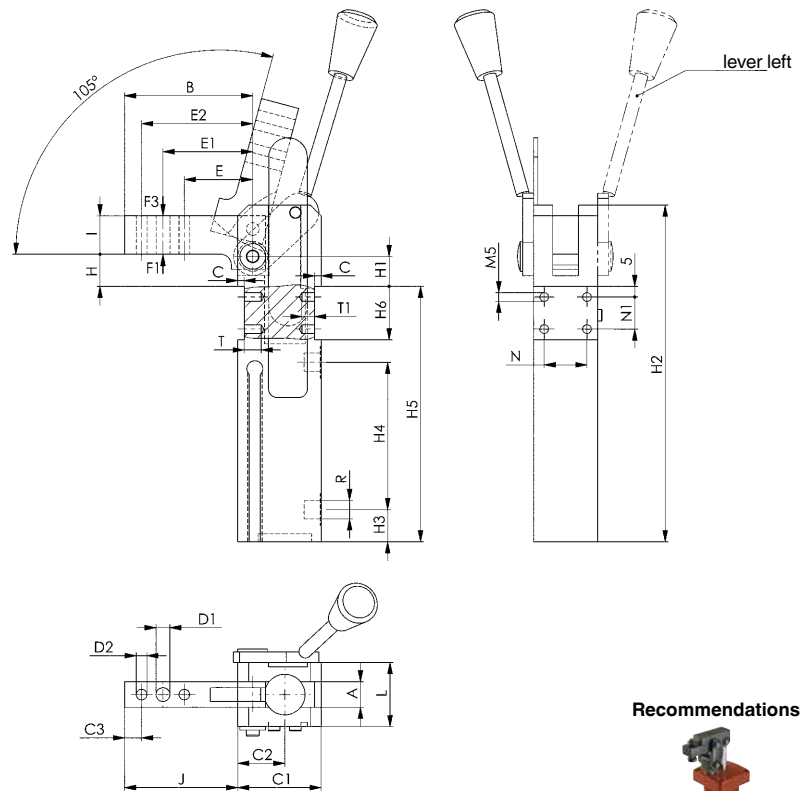

Recommendations



No. 6829V,
page 144



No. 6828M,
page 148



No. 6828U,
page 152



Dimensions:

Order no.	Size	A	B	C	C1	C2	C3	D1	D2 H7	E	E1	E2	H	H1	H2	H3	H4	H5	H6 +0.1	I	J	L	N ±0.1	N1 ±0.1	R	T	T1	Piston dia.
555083	16	10	50	2,5	32	18	6	5,5	4	28	36,0	44	7,5	7,5	123	12,0	57	96	20	15	44	26	16	10	M5	7	5	16
555170	16	10	50	2,5	32	18	6	5,5	4	28	36,0	44	7,5	7,5	123	12,0	57	96	20	15	44	26	16	10	M5	7	5	16
555084	20	12	60	3,0	39	22	8	6,5	5	32	42,0	52	15,0	14,0	158	15,0	69	120	25	18	53	30	20	15	G1/8	8	6	20
555171	20	12	60	3,0	39	22	8	6,5	5	32	42,0	52	15,0	14,0	158	15,0	69	120	25	18	53	30	20	15	G1/8	8	6	20
555085	25	16	75	4,0	45	25	10	8,5	6	40	52,5	65	19,0	17,0	182	17,5	80	136	28	22	68	35	25	18	G1/8	8	6	25
555172	25	16	75	4,0	45	25	10	8,5	6	40	52,5	65	19,0	17,0	182	17,5	80	136	28	22	68	35	25	18	G1/8	8	6	25

Subject to technical alterations.

Force diagrams 6828M and 6828H

Size 10

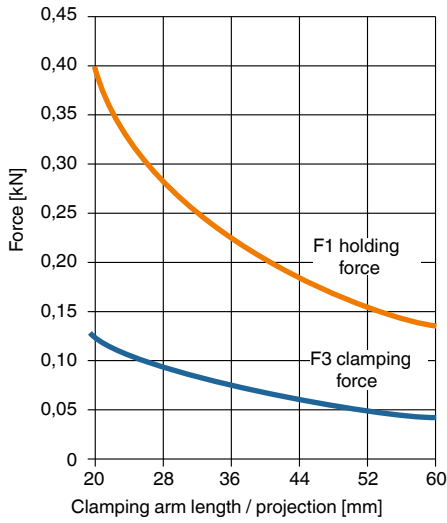

Size 16

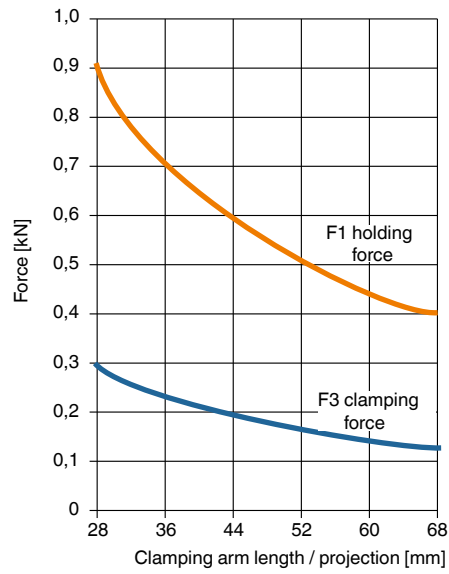

Size 20

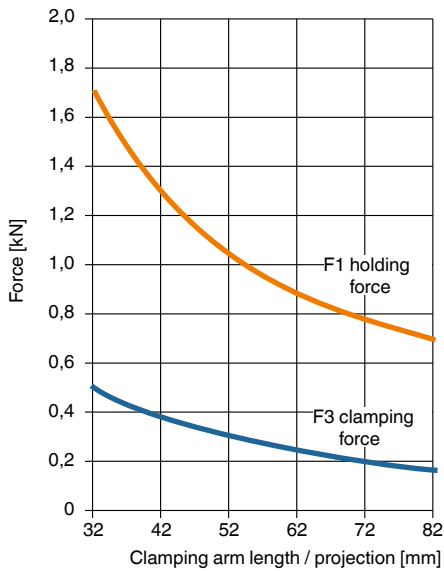

Size 25

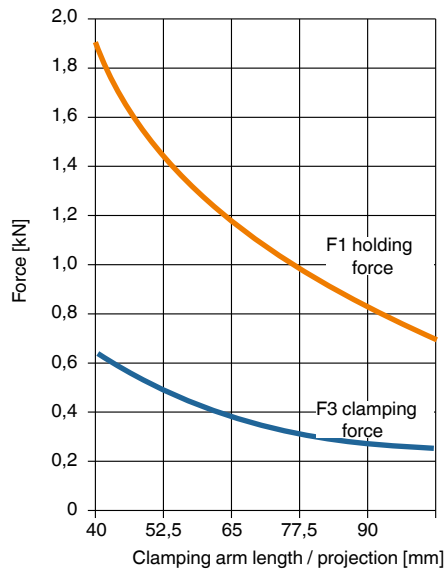

Examples of mountings:

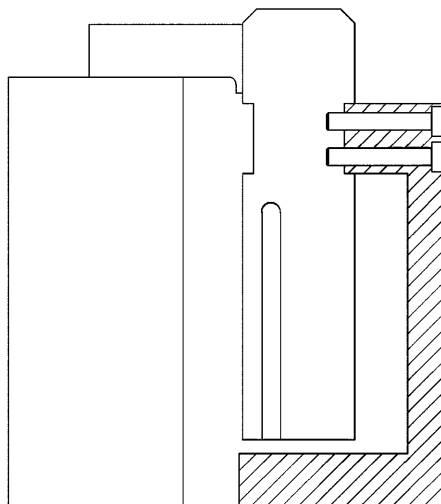
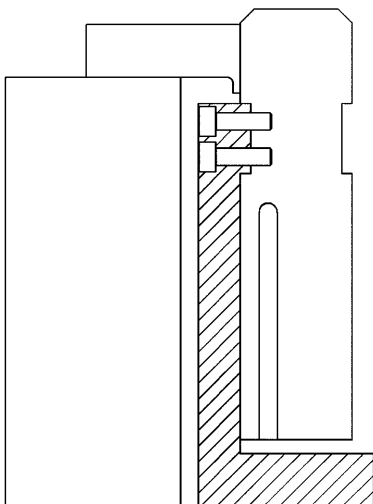

Subject to technical alterations.

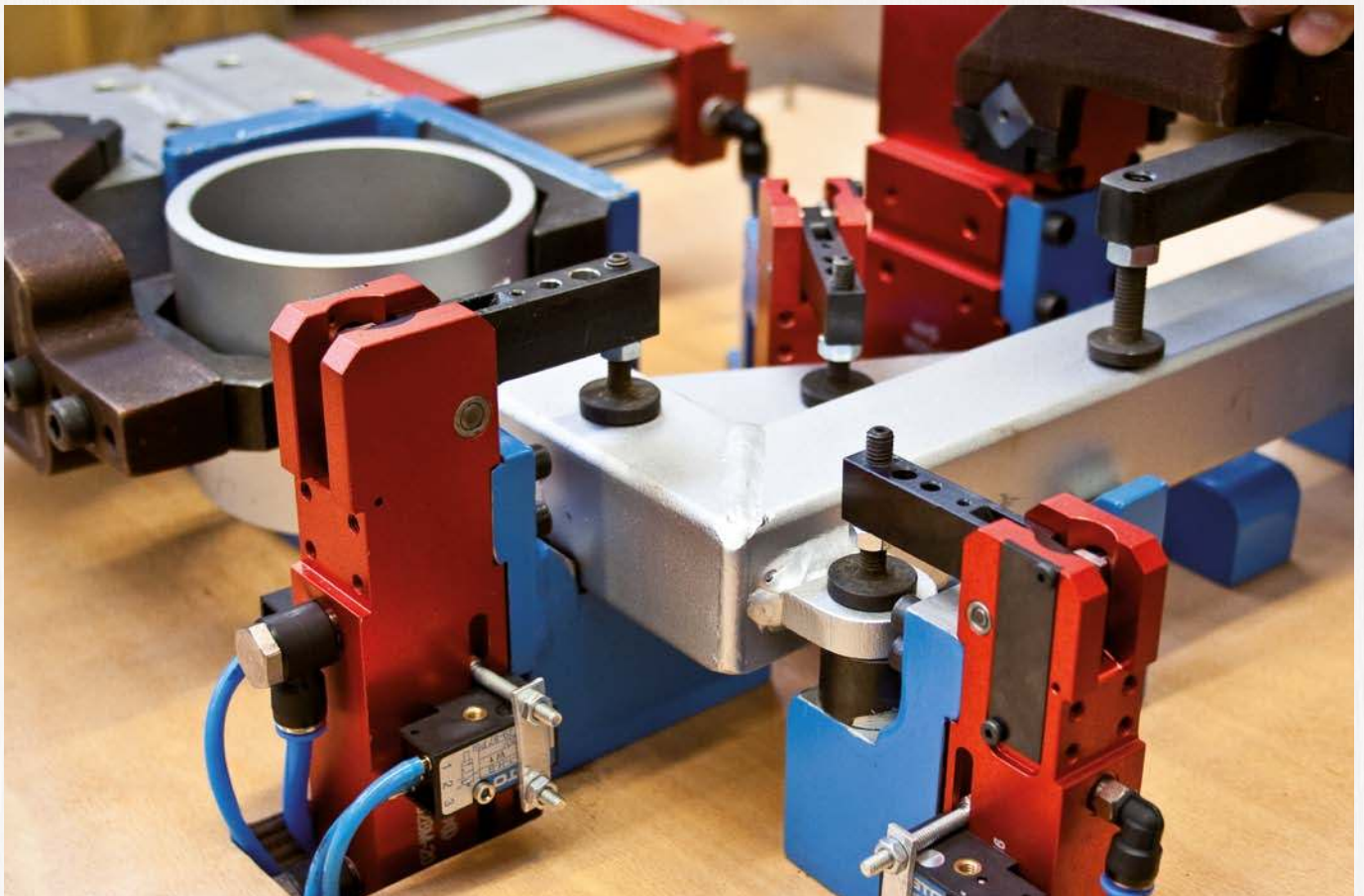
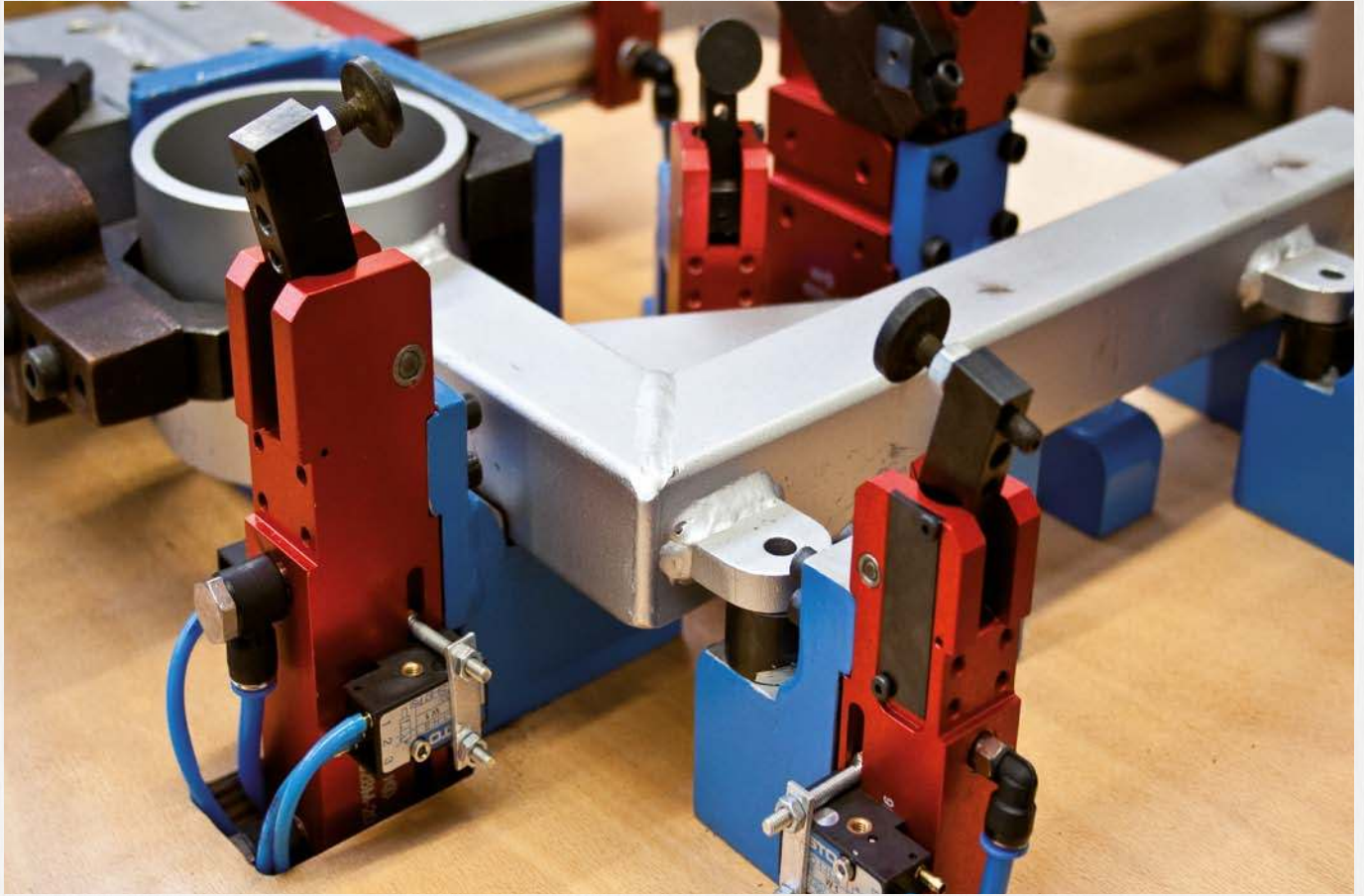

Subject to technical alterations.

No. 6828U

Heavy pneumatic toggle clamp

Double-acting.

Max. operating pressure 6 bar. With continuously adjustable opening angle in the range 10° to 135°. Aluminium case. With pneumatic end position cushioning and self-locking. With inductive query 24V as standard. **Delivery without clamp arm.**

Accessories (not supplied as standard):

- Clamping arm no. 6828SP centre, right and left
- Connecting plug for inductive query

Order no.	Size	Clamping moment at 5 bar		Holding moment max.		Weight [Kg]
		[Nm]		[Nm]		
565864	40	120		380		2,0
565865	50	160		800		3,6
565866	63	380		1500		4,8

Application:

These pneumatic clamps are suitable for use in material handling lines and special machines.

Opening and clamping position of the clamp can be controlled electrically, allowing integration into automated manufacturing processes.

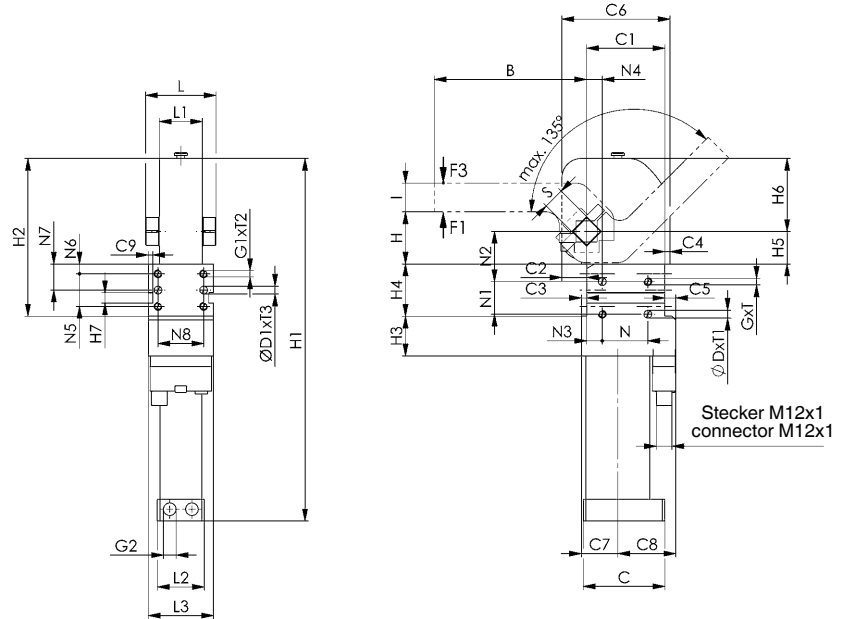

Connection sketch

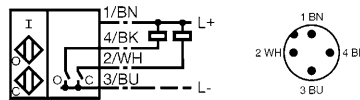

O ... open
C ... close

Recommendations



No. 6828SP,
page 153



No. 6829V,
page 144



No. 6826A,
page 142

Dimensions:

Order no.	Size	B	C	C1 *	C2	C3	C4	C5	C6	C7	C8	C9	dia. D H7	dia. D1 H7	G	G1	G2	H ±0.2	H1	H2	H3	H4 +0.1	H5
565864	40	117	62,5	60	19,0	4,0	4,0	8,5	83	28	44,5	3,5	6	6	M6	M6	G1/8	40,5	278	121,0	30,5	40	25,0
565865	50	144	82,0	93	10,5	6,5	4,5	4,5	108	50	54,0	-	-	8	-	M8	G1/8	51,5	286	149,5	16,5	55	36,5
565866	63	144	106,0	93	11,0	6,5	5,0	17,0	109	53	63,5	-	-	8	-	M8	G1/4	51,5	329	158,5	16,5	55	36,5

Order no.	Size	H6	H7 N9	I ±0,1	L	L1 -0.5	L2	L3	N*	N1*	N2 ±0.05	N3 ±0.05	N4 ±0.05	N5*	N6 ±0.1	N7 ±0.05	N8*	S h9	T	T1	T2	T3	Piston dia.
565864	40	56	8	22	54	33	36	50	35	25	38,5	12	12	25	7,5	20	35	16	9	8	12	8	40
565865	50	58	-	28	69	45	48	48	-	-	-	-	-	32	11,0	27	30	19	-	-	12	12	50
565866	63	67	-	28	79	48	43	48	-	-	-	-	-	32	11,0	27	30	22	-	-	12	12	63

* Tolerance for peg holes ±0.02 mm; for threaded holes ±0.1 mm.

Subject to technical alterations.

Force diagrams 6828U-40

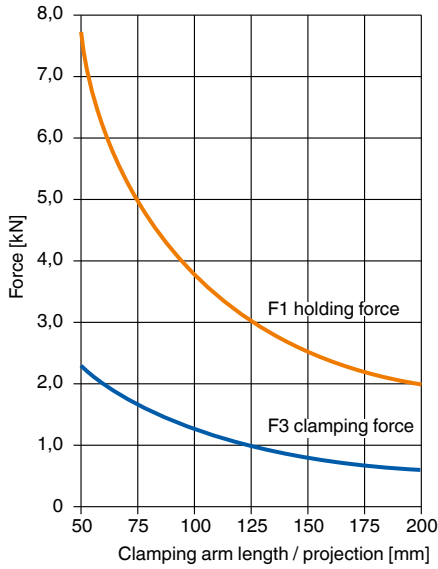

6828U-50

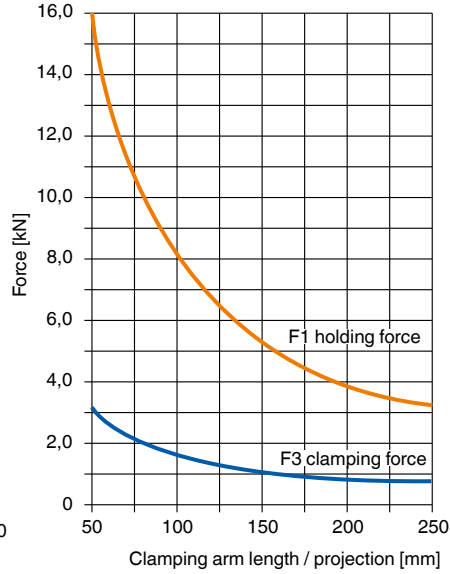

6828U-63

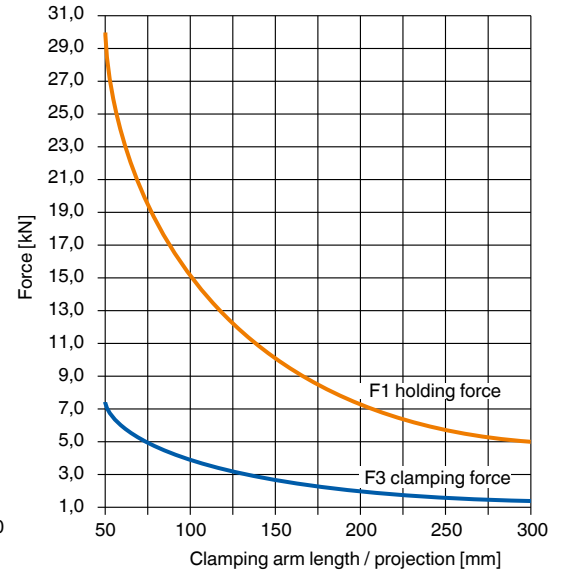

No. 6828SP

Clamp arm

made of steel, for heavy pneumatic toggle clamp no. 6828U, size 40, 50, 63.



Order no.	Size	Article no.	A -0,1	A1 ±0,1	A2	A3	B	B1 ±0,02	B2 ±0,2	B3 ±0,1	dia. D	Weight [g]
92080	40	6828SPL-40	16	23	31	54	117	20	20	90	7	520
91900	40	6828SPM-40	16	-	-	54	117	20	20	90	7	520
92007	40	6828SPR-40	16	23	31	54	117	20	20	90	7	520
92072	50	6828SPL-50	20	34	44	68	144	30	30	105	9	855
91959	50	6828SPM-50	20	-	-	68	144	30	30	105	9	855
92056	50	6828SPR-50	20	34	44	68	144	30	30	105	9	855
92130	63	6828SPL-63	20	37	47	78	144	30	30	105	9	1150
92098	63	6828SPM-63	20	-	-	78	144	30	30	105	9	1150
92114	63	6828SPR-63	20	37	47	78	144	30	30	105	9	1150

Clamp arm variants:

SPL (Clamp arm left)

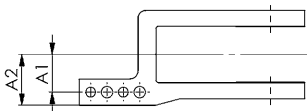

SPM (Clamp arm in the middle)

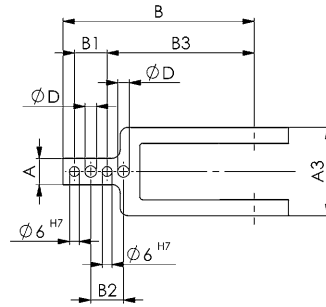

SPR (Clamp arm right)

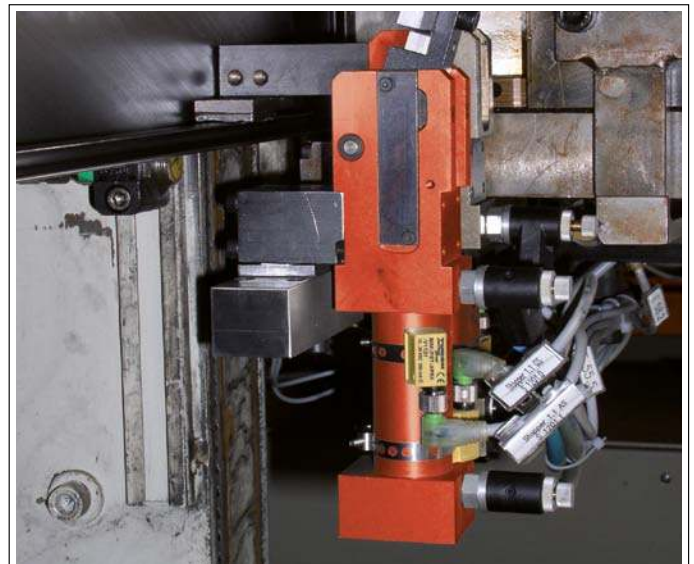
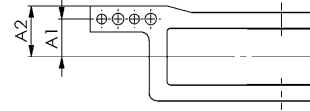

Subject to technical alterations.

PNEUMATIC SWING CLAMPS

> APPLICATIONS

Pneumatic swing clamps are used where low clamping forces are needed (e.g. for welding), and where workpieces must be easily positioned from above.

> POINTS TO REMEMBER!

The swing action of toggle clamps must not be hindered. They can only clamp on their vertical stroke, not while swinging.

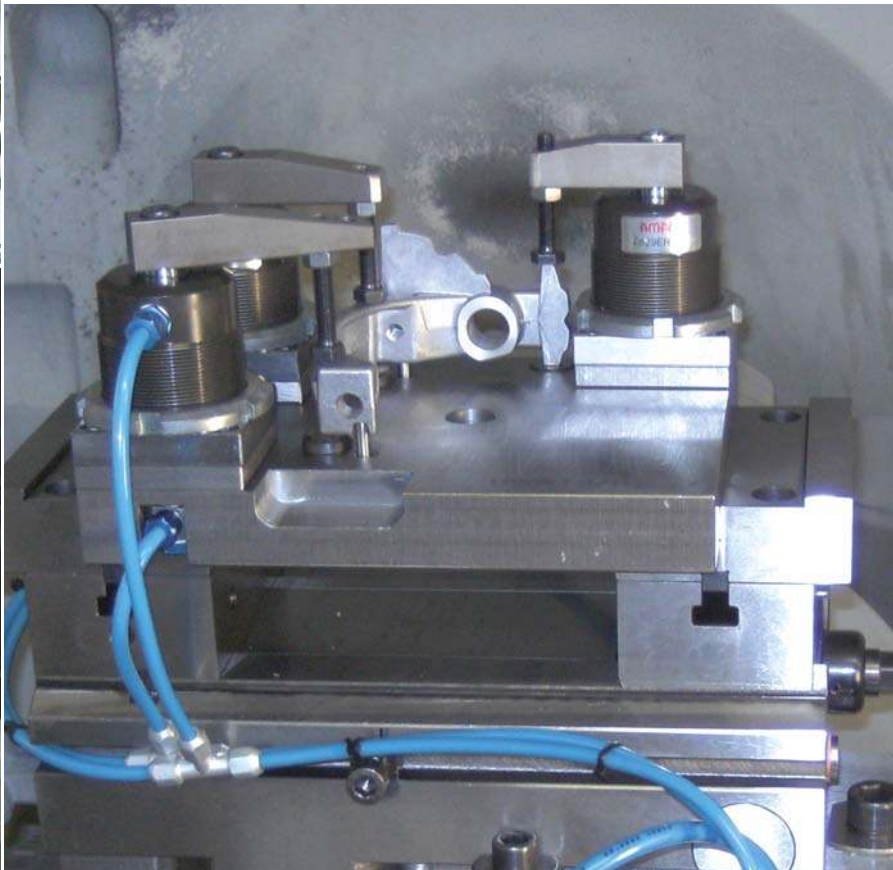
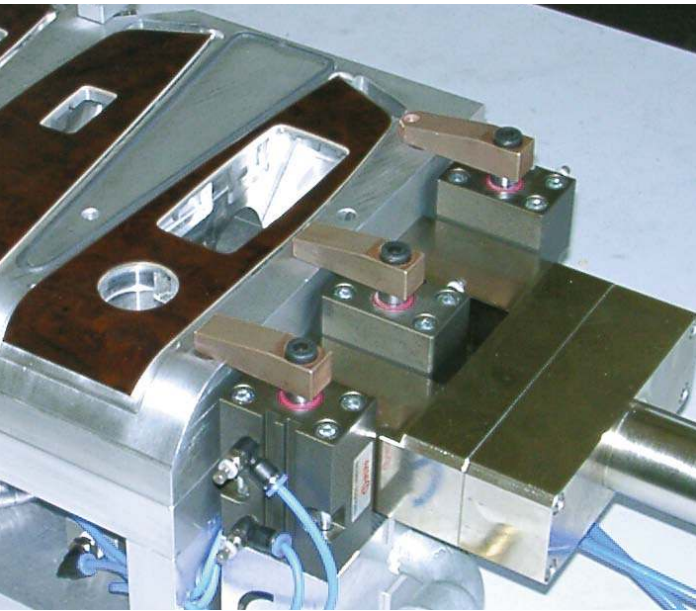

No. 6829KR/KL

Swing clamp, pneumatic, flange-mounting version

double-acting

For recessed installation in fixtures. Both compressed-air connections are in the flange. Piston rod non-rusting, polished. Body is made of aluminium, anodised. HART-COAT® surface for wear-resistance. Including screw and spring washer for simple setting of the clamp arm position.

Mounting:

- from above with cap screws through the flange
- from below in a bore in the fixture using grooved nuts and clamping against the flange
- from above with grooved nuts against the fixture

Accessories (not included in pack):

- Clamping arm 6829SP
- Grooved nut 6829N
- Clamping screw 6880



CAD



Order no.	Size	right swinging	left swinging	F3 [kN]	Connecting thread for clamping screws	Weight [g]
560012	12	●	-	0,03	M4	130
560018	12	-	●	0,03	M4	130
560011	16	●	-	0,06	M4	180
560019	16	-	●	0,06	M4	180
560010	20	●	-	0,08	M6	300
560020	20	-	●	0,08	M6	300
93484	25	●	-	0,17	M6	500
93559	25	-	●	0,17	M6	500
93492	32	●	-	0,27	M8	650
93567	32	-	●	0,27	M8	650
93500	40	●	-	0,45	M8	800
93575	40	-	●	0,45	M8	800
93518	50	●	-	0,70	M12	920
93583	50	-	●	0,70	M12	920
93526	63	●	-	1,10	M12	1080
93591	63	-	●	1,10	M12	1080

F3 = at 6 bar max. air pressure

Note:

The mounting holes in the flange are the same as in threaded flange no. 6828GF. Operate only with lubricated air.

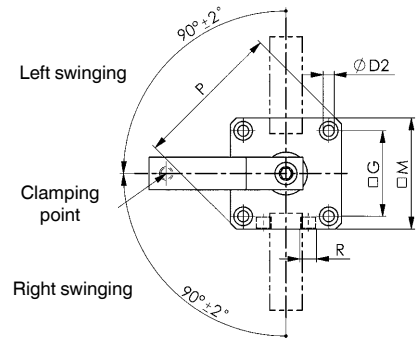
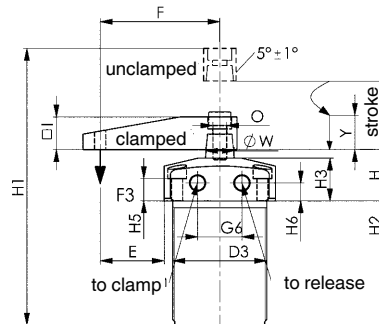

Examples of mountings:

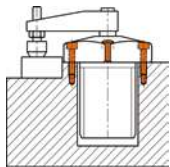

with 4 cap screws from above

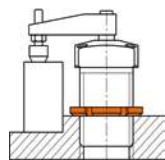

with grooved nut from above

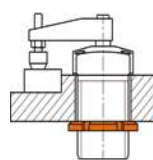

with grooved nut from below

Recommendations



No. 6829SP,
page 159



No. 6829N,
page 160



No. 6829GF,
page 160

Dimensions:

Order no.	Size	dia. D2	D3	E	F	G	G6	H	H1	H2	H3	H5	H6	I	M	O	P	R	dia. W	Piston dia.	Y Clamping stroke*	Stroke
560012	12	4,5	M25x1,5	18,7	35	23,0	10	25	105	50	20	11	9,0	12,0	33	M5	43	M5	8	12	8,6	17,6
560018	12	4,5	M25x1,5	18,7	35	23,0	10	25	105	50	20	11	9,0	12,0	33	M5	43	M5	8	12	8,6	17,6
560011	16	4,5	M30x1,5	23,0	41	26,5	12	25	105	50	20	11	9,0	12,0	36	M5	47	M5	8	16	8,5	17,5
560019	16	4,5	M30x1,5	23,0	41	26,5	12	25	105	50	20	11	9,0	12,0	36	M5	47	M5	8	16	8,5	17,5
560010	20	4,5	M35x1,5	27,5	48	30,5	14	26	107	65	20	10	9,0	16,0	41	M8	54	M5	12	20	15,0	27,0
560020	20	4,5	M35x1,5	27,5	48	30,5	14	26	107	65	20	10	9,0	16,0	41	M8	54	M5	12	20	15,0	27,0
93484	25	5,5	M40x1,5	25,0	50	37,0	23	30	135	62	25	15	11,5	16,0	50	M8	66	M5	14	25	13,0	26,0
93559	25	5,5	M40x1,5	25,0	50	37,0	23	30	135	62	25	15	11,5	16,0	50	M8	66	M5	14	25	13,0	26,0
93492	32	6,5	M50x1,5	30,0	60	45,0	23	30	152	73	25	13	10,5	19,0	60	M8	80	G1/8	16	32	14,0	28,0
93567	32	6,5	M50x1,5	30,0	60	45,0	23	30	152	73	25	13	10,5	19,0	60	M8	80	G1/8	16	32	14,0	28,0
93500	40	6,5	M55x1,5	37,5	70	50,0	26	30	152	73	25	13	10,5	19,0	65	M8	87	G1/8	16	40	16,0	30,0
93575	40	6,5	M55x1,5	37,5	70	50,0	26	30	152	73	25	13	10,5	19,0	65	M8	87	G1/8	16	40	16,0	30,0
93518	50	8,5	M65x1,5	42,5	80	58,0	32	30	164	80	25	11	10,5	25,5	75	M10	100	G1/8	20	50	16,0	32,0
93583	50	8,5	M65x1,5	42,5	80	58,0	32	30	164	80	25	11	10,5	25,5	75	M10	100	G1/8	20	50	16,0	32,0
93526	63	8,5	M80x1,5	45,0	90	70,0	35	30	164	80	25	11	10,5	25,5	90	M10	118	G1/8	20	63	14,0	30,0
93591	63	8,5	M80x1,5	45,0	90	70,0	35	30	164	80	25	11	10,5	25,5	90	M10	118	G1/8	20	63	14,0	30,0

* Swing clamps may only be loaded during the clamping stroke Y.

Subject to technical alterations.

No. 6829BR/BL

Swing clamp, pneumatic, block version

double-acting

Piston rod non-rusting, polished. Body is made of aluminium, anodised. HART-COAT® surface for wear-resistance. **Magnetic piston to signal end positions.** Including screw and spring washer for simple setting of the clamp arm position.

Mounting:

- on front or rear faces, using through holes
- from above with long socket bolts ISO 4762 (DIN 912)
- from below using tapped holes in base

Accessories (not included in pack):

- Clamping arm 6829SP
- Clamping screw 6880

Order no.	Size	right swinging	left swinging	F3 [kN]	Connecting thread for clamping screws	Weight [g]
91496	12	●	-	0,03	M 4	200
91397	12	-	●	0,03	M 4	200
91504	16	●	-	0,06	M 4	300
91405	16	-	●	0,06	M 4	300
91512	20	●	-	0,08	M 6	400
91413	20	-	●	0,08	M 6	400
91520	25	●	-	0,17	M 6	600
91421	25	-	●	0,17	M 6	600
91538	32	●	-	0,27	M 8	800
91439	32	-	●	0,27	M 8	800
91546	40	●	-	0,45	M 8	920
91447	40	-	●	0,45	M 8	920
91553	50	●	-	0,70	M12	1000
91454	50	-	●	0,70	M12	1000
91561	63	●	-	1,10	M12	1150
91462	63	-	●	1,10	M12	1150

F3 = at 6 bar max. air pressure

Note:

Suitable proximity switches for end-position monitoring are available using order no. 392241. Design: PUR cable 0,3 m with M8 plug connection and rotating knurled nuts. Switching function: NOC. Output: PNP. Operate only with lubricated air.



Recommendations



No. 6880,
page 166



No. 6829SP,
page 159



No. 6829ER/EL,
page 158

Examples of mountings:

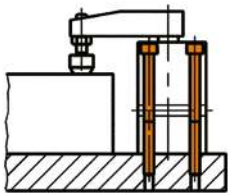

from above

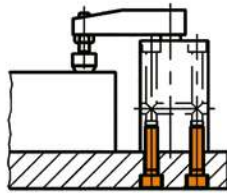

from below

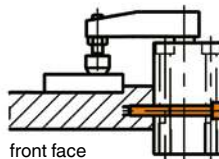

front face

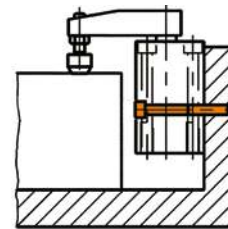

rear face

CAD



Subject to technical alterations.

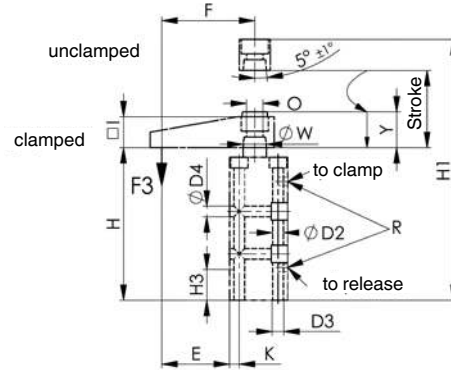
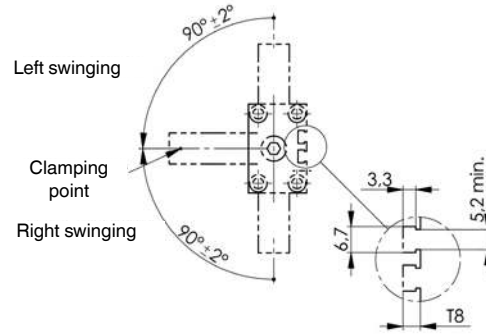
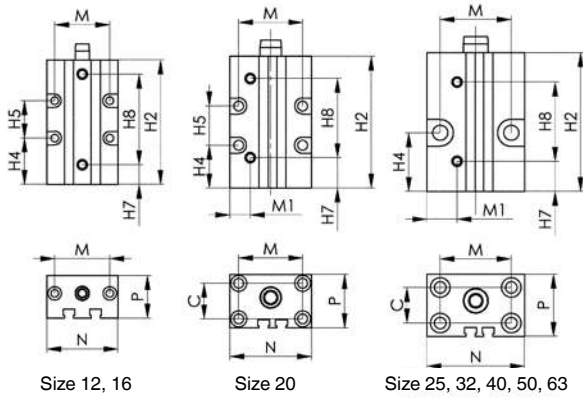

Dimensions:

Order no.	Size	C	dia. D2	D3	dia. D4	E	F	H	H1	H2	H3	H4	H5	H7	H8
91496	12	-	4,3	M 5	4,3	25,0	35	76	105	70	15	26	21	11	51,0
91397	12	-	4,3	M 5	4,3	25,0	35	76	105	70	15	26	21	11	51,0
91504	16	-	4,3	M 5	4,3	30,0	41	76	105	70	15	26	21	11	51,0
91405	16	-	4,3	M 5	4,3	30,0	41	76	105	70	15	26	21	11	51,0
91512	20	20	5,5	M 6	5,5	35,0	48	80	125	74	20	24	22	17	44,5
91413	20	20	5,5	M 6	5,5	35,0	48	80	125	74	20	24	22	17	44,5
91520	25	20	6,5	M 8	8,5	35,0	50	83	125	78	20	32	-	17	44,5
91421	25	20	6,5	M 8	8,5	35,0	50	83	125	78	20	32	-	17	44,5
91538	32	30	6,5	M 8	8,5	40,0	60	96	145	90	20	43	-	22	50,0
91439	32	30	6,5	M 8	8,5	40,0	60	96	145	90	20	43	-	22	50,0
91546	40	37	8,5	M10	8,5	45,5	70	96	145	90	25	40	-	20	52,0
91447	40	37	8,5	M10	8,5	45,5	70	96	145	90	25	40	-	20	52,0
91553	50	46	8,5	M10	10,5	49,0	80	106	162	100	30	45	-	25	53,5
91454	50	46	8,5	M10	10,5	49,0	80	106	162	100	30	45	-	25	53,5
91561	63	60	10,5	M12	10,5	52,5	90	106	162	100	30	36	-	28	53,0
91462	63	60	10,5	M12	10,5	52,5	90	106	162	100	30	36	-	28	53,0

Order no.	Size	I	K	M	M1	N	O	P	R	T8	dia. W	Piston dia.	Y Clamping stroke*	Stroke
91496	12	12	10,0	31	20,0	40	M 5	24	M 5	5,0	8	12	8,5	17,5
91397	12	12	10,0	31	20,0	40	M 5	24	M 5	5,0	8	12	8,5	17,5
91504	16	12	13,0	31	21,0	42	M 5	28	M 5	4,5	8	16	8,5	17,5
91405	16	12	13,0	31	21,0	42	M 5	28	M 5	4,5	8	16	8,5	17,5
91512	20	16	5,0	36	11,5	46	M 8	30	M 5	4,5	12	20	14,0	27,0
91413	20	16	5,0	36	11,5	46	M 8	30	M 5	4,5	12	20	14,0	27,0
91520	25	16	7,5	40	17,0	55	M 8	35	M 5	5,0	14	25	14,0	27,0
91421	25	16	7,5	40	17,0	55	M 8	35	M 5	5,0	14	25	14,0	27,0
91538	32	19	7,5	45	18,0	60	M 8	45	G1/8	6,5	16	32	15,5	30,0
91439	32	19	7,5	45	18,0	60	M 8	45	G1/8	6,5	16	32	15,5	30,0
91546	40	19	9,0	52	22,0	70	M 8	55	G1/8	8,0	16	40	15,5	30,0
91447	40	19	9,0	52	22,0	70	M 8	55	G1/8	8,0	16	40	15,5	30,0
91553	50	25	9,5	66	25,0	85	M10	65	G1/8	6,5	20	50	15,0	31,0
91454	50	25	9,5	66	25,0	85	M10	65	G1/8	6,5	20	50	15,0	31,0
91561	63	25	10,0	80	30,0	100	M10	80	G1/8	8,5	20	63	15,0	31,0
91462	63	25	10,0	80	30,0	100	M10	80	G1/8	8,5	20	63	15,0	31,0

* Swing clamps may only be loaded during the clamping stroke Y.

No. 6829ER/EL

Swing clamp, pneumatic, screw-in version

double-acting

Piston rod non-rusting, polished. Body is made of aluminium, anodised. HART-COAT® surface for wear-resistance. Including screw and spring washer for simple setting of the clamp arm position.

Mounting:

- with grooved nut 6829N (DIN 70852)
- with threaded flange 6829GF

Accessories (not included in pack):

- Clamping arm 6829SP
- Grooved nut 6829N
- Thread flange 6829GF
- Clamping screw 6880



Recommendations



No. 6829SP, page 159



No. 6829N, page 160



No. 6829GF, page 160

Order no.	Size	right swinging	left swinging	F3 [kN]	Connecting thread for clamping screws	Weight [g]
560062	12	●	-	0,03	M4	100
560027	12	-	●	0,03	M4	100
560063	16	●	-	0,06	M4	150
560028	16	-	●	0,06	M4	150
560064	20	●	-	0,08	M6	270
560029	20	-	●	0,08	M6	270
92809	25	●	-	0,17	M 6	450
92858	25	-	●	0,17	M 6	450
92817	32	●	-	0,27	M 8	550
92866	32	-	●	0,27	M 8	550
92825	40	●	-	0,45	M 8	700
92874	40	-	●	0,45	M 8	700
92833	50	●	-	0,70	M12	850
92882	50	-	●	0,70	M12	850
92841	63	●	-	1,10	M12	1000
92890	63	-	●	1,10	M12	1000

F3 = at 6 bar max. air pressure

Note:

Operate only with lubricated air.

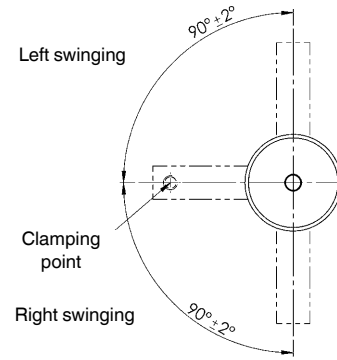
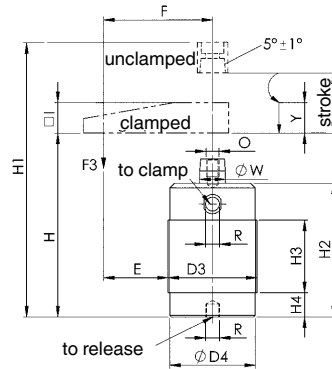

Order no.	Size	D3	dia. D4	E	F	H	H1	H2	H3	H4	I	O	R	dia. W	Piston dia.	Y Clamping stroke*	Stroke
560062	12	M25x1,5	23	22,5	35	75	105	70	48	2	12,0	M5	M5	8	12	8,6	17,6
560027	12	M25x1,5	23	22,5	35	75	105	70	48	2	12,0	M5	M5	8	12	8,6	17,6
560063	16	M30x1,5	28	26,0	41	75	105	70	48	2	12,0	M5	M5	8	16	8,5	17,5
560028	16	M30x1,5	28	26,0	41	75	105	70	48	2	12,0	M5	M5	8	16	8,5	17,5
560064	20	M35x1,5	33	30,5	48	91	134	85	64	2	16,0	M8	M5	12	20	15,0	27,0
560029	20	M35x1,5	33	30,5	48	91	134	85	64	2	16,0	M8	M5	12	20	15,0	27,0
92809	25	M40x1,5	38	30,0	50	73	118	70	34	12	16,0	M 8	M 5	14	25	13,0	26,0
92858	25	M40x1,5	38	30,0	50	73	118	70	34	12	16,0	M 8	M 5	14	25	13,0	26,0
92817	32	M50x1,5	48	35,0	60	83,5	132	79	43	15	19,0	M 8	G1/8	16	32	15,5	29,5
92866	32	M50x1,5	48	35,0	60	83,5	132	79	43	15	19,0	M 8	G1/8	16	32	15,5	29,5
92825	40	M55x1,5	53	42,5	70	85,5	136	83	47	15	19,0	M 8	G1/8	16	40	16,5	30,5
92874	40	M55x1,5	53	42,5	70	85,5	136	83	47	15	19,0	M 8	G1/8	16	40	16,5	30,5
92833	50	M65x1,5	62	47,5	80	92	148	87	50	15	25,0	M10	G1/8	20	50	14,0	30,0
92882	50	M65x1,5	62	47,5	80	92	148	87	50	15	25,0	M10	G1/8	20	50	14,0	30,0
92841	63	M80x1,5	77	50,0	90	98	153	92	55	15	25,0	M10	G1/8	20	63	13,5	29,5
92890	63	M80x1,5	77	50,0	90	98	153	92	55	15	25,0	M10	G1/8	20	63	13,5	29,5

* Swing clamps may only be loaded during the clamping stroke Y.

Examples of mountings:



with grooved nut from below

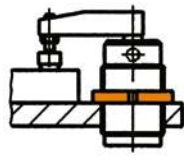

with grooved nut from above



with threaded flange and grooved nut

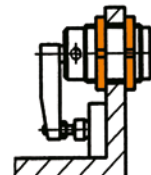

with two grooved nuts

Subject to technical alterations.

No. 6829SP

Clamping arm

High-strength aluminium alloy. HART-COAT® surface for wear-resistance and reduced adhesion of weld spatter. With thread for clamping screw No. 6880.

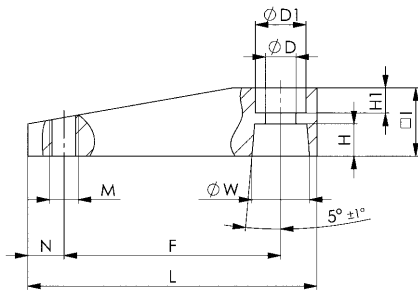

Order no.	Size	dia. D	dia. D1	F	H	H1	I	L	M	N	dia. W	Weight [g]
92486	12	5,5	9	35	5,0	5,0	12	45	M4	4	8	13
92494	16	5,5	9	41	5,0	4,0	12	51	M4	4	8	15
92502	20	8,5	14	48	5,5	7,5	16	64	M6	6	12	31
93674	25	8,5	14	50	6,5	6,0	16	66	M6	6	14	32
93682	32	8,5	14	60	9,0	7,0	19	80	M8	10	16	55
93690	40	8,5	14	70	9,0	7,0	19	90	M8	10	16	65
93708	50	10,5	17	80	10,0	9,0	25	105	M12	10	20	132
93716	63	10,5	17	90	10,0	9,0	25	115	M12	10	20	149

Note:

Fitting clamping arm:

- 1) Set up clamping arm with spring washer and screw without play.
- 2) Turn clamping arm into position.
- 3) Hold clamping arm fixed with wrench and tighten screw.

Clamping arm removal:

- 1) Hold clamping arm fixed with wrench and loosen screw.
 - 2) With light blows from below (plastic hammer), separate clamping arm from the piston rod.
- Caution! No side blows permitted!



Application example:

Clamping arm with clamping screw no. 6880.

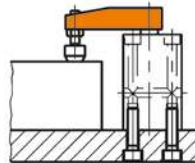

No. 6829AD

Adapter

for mounting special clamping arms, with taper bore and mounting holes for arm. High-strength aluminium alloy. HART-COAT® surface for wear-resistance and reduced adhesion of weld spatter.

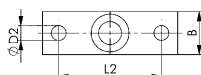
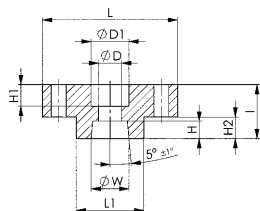

Order no.	Size	B	dia. D	dia. D1	dia. D2	H	H1	H2	I	L	L1	L2	dia. W	Weight [g]
92403	12/16	12	5,5	10	4,5	5,0	7,0	6	14	30	13	22	8	8
92411	20	16	8,5	14	5,5	5,5	10,5	8	20	40	18	30	12	20
92429	25	16	8,5	14	5,5	6,5	8,0	8	20	50	25	38	14	28
92437	32/40	19	8,5	14	7,0	9,0	11,0	10	25	60	30	45	16	50
92452	50/63	25	10,5	17	9,0	10,0	14,0	12	30	65	30	48	20	80

Application example:

Adapter in use as a connecting element between an individual clamping arm and the piston rod of a pneumatic swing clamp no. 6829.

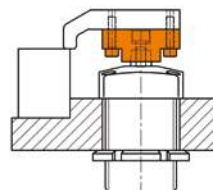

No. 6829N

Grooved nut (DIN 70852)

Steel, galvanized.
Use hook spanner for tightening (see AMF catalogue „Hand Tools“).



Order no.	Size	B	C	dia. D1	dia. D2	D3	H	Weight [g]
560083	12 *	5,0	2,0	32	38	M25x1,5	7	32
560084	16	6,5	2,8	38	44	M30x1,5	7	36
560085	20	7,0	3,3	43	50	M35x1,5	8	51
92924	25	7,0	3,3	49	56	M40x1,5	8	63
92932	32	8,0	3,8	60	68	M50x1,5	8	84
92940	40	8,0	3,8	67	75	M55x1,5	8	106
92957	50	11,0	4,3	76	85	M65x1,5	9	132
92973	63	11,0	4,3	91	100	M80x1,5	10	180

* according to DIN 981

Application example:

Grooved nut from above for locking swing clamp in a fixture.

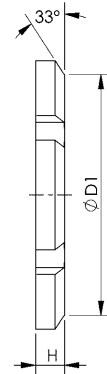
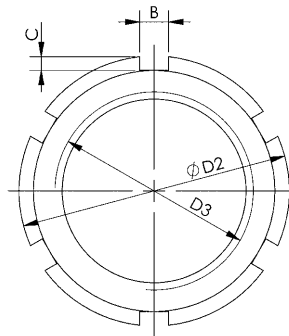

No. 6829GF

Threaded flange

Aluminium.
With four counterbored mounting holes. Female screw-in thread for swing clamp. Use grooved nut to lock in desired.



Order no.	Size	C	dia. D1	dia. D2	D3	H	H1	L	Weight [g]
560065	12	24	8	4,5	M25x1,5	8	5	35	15
560066	16	29	8	4,5	M30x1,5	8	5	40	18
560067	20	32	9	5,5	M35x1,5	9	6	45	25
93062	25	37	9	5,5	M40x1,5	9	6	50	30
93070	32	45	11	6,5	M50x1,5	12	7	60	50
93088	40	50	11	6,5	M55x1,5	12	7	65	55
93096	50	58	13	8,5	M65x1,5	15	9	75	85
93104	63	70	13	8,5	M80x1,5	15	9	88	102

Advantage:

Avoids cutting a large thread in the fixture.

Note:

The mounting holes in the flange are the same as in pneumatic clamp flange no. 6829K and 6829V.

Application example:

Swing clamp screwed into threaded flange.

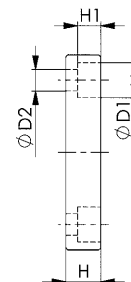
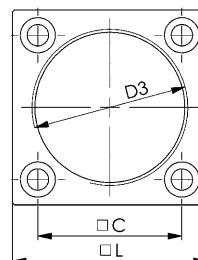

Subject to technical alterations.

No. 6829WR/WL

Swing Clamp with welding protection, pneumatic

double acting

Piston rod non-rusting, polished and protected against weld spatter. Body, welding protection and clamping arm made of aluminium, anodised. HART-COAT® surface for wear-resistance.

Magnetic piston for end-position monitoring.

Clamp arm not included.

Accessories (not included in pack):

- Welding protection no. 6829WS
- Clamping arm no. 6829WSP



Recommendations



No. 6829WS,
page 162



No. 6829WSP,
page 162



No. 6829BR/BL,
page 156

Order no.	Size	right swinging		left swinging		F3 [kN]	Weight [g]
		●	-	-	●		
91579	25	●	-	-	-	0,2	326
92361	25	-	●	-	-	0,2	326
91595	32	●	-	-	-	0,3	537
92387	32	-	●	-	-	0,3	537
91611	40	●	-	-	-	0,6	680
92445	40	-	●	-	-	0,6	680
91637	50	●	-	-	-	0,9	1160
92460	50	-	●	-	-	0,9	1160
91652	63	●	-	-	-	1,4	1520
92478	63	-	●	-	-	1,4	1520

F3 = at 6 bar max. air pressure

Note:

Suitable proximity switches for end-position monitoring are available using order no. 392241.

Design: PUR cable 0.3 m with M8 plug connection and rotating knurled nuts.

Switching function: NOC. Output: PNP.

Operate only with lubricated air.

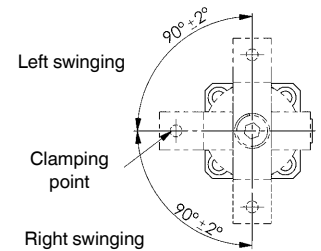
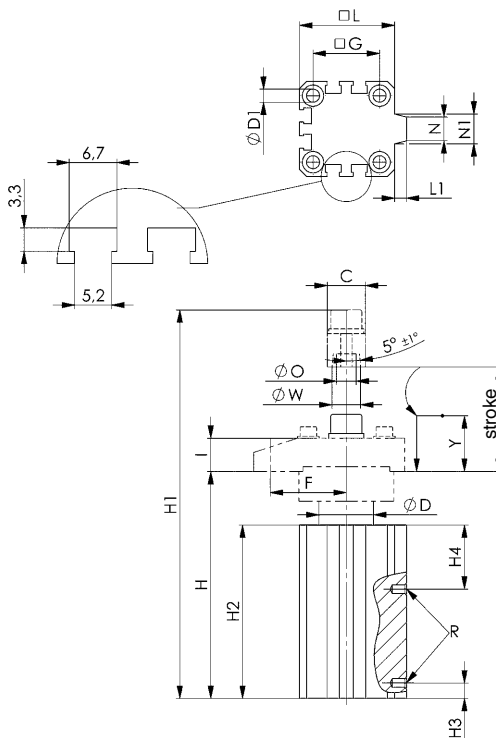

Dimensions:

Order no.	Size	C	dia. D	dia. D1	F	G	H	H1	H2	H3	H4	I	L	L1	N	N1	dia. O	R	dia. W	Piston dia.	Y Clamping stroke*	Stroke
91579	25	16	23	5,5	32,0	29	95,5	139,0	73,0	6,5	27,0	14	40	5,0	9,6	12,5	8,3	M5	12	25	10	19,5
92361	25	16	23	5,5	32,0	29	95,5	139,0	73,0	6,5	27,0	14	40	5,0	9,6	12,5	8,3	M5	12	25	10	19,5
91595	32	22	30	5,5	45,0	34	113,0	168,0	80,0	9,0	34,5	18	45	4,5	14,5	16,5	10,5	G1/8	16	32	10	25,0
92387	32	22	30	5,5	45,0	34	113,0	168,0	80,0	9,0	34,5	18	45	4,5	14,5	16,5	10,5	G1/8	16	32	10	25,0
91611	40	22	30	5,5	45,0	40	114,0	173,0	80,0	9,0	34,5	22	52	5,0	18,0	22,0	10,5	G1/8	16	40	10	25,0
92445	40	22	30	5,5	45,0	40	114,0	173,0	80,0	9,0	34,5	22	52	5,0	18,0	22,0	10,5	G1/8	16	40	10	25,0
91637	50	25	37	6,6	65,0	50	149,4	227,9	101,5	11,0	39,0	25	64	7,0	20,0	23,0	12,5	G1/4	20	50	20	39,0
92460	50	25	37	6,6	65,0	50	149,4	227,9	101,5	11,0	39,0	25	64	7,0	20,0	23,0	12,5	G1/4	20	50	20	39,0
91652	63	25	47	9,0	72,5	60	152,9	231,4	104,0	10,0	35,0	25	77	7,0	28,0	33,0	12,5	G1/4	20	63	20	39,0
92478	63	25	47	9,0	72,5	60	152,9	231,4	104,0	10,0	35,0	25	77	7,0	28,0	33,0	12,5	G1/4	20	63	20	39,0

* Swing clamps may only be loaded during the clamping stroke Y.

CAD



No. 6829WS

Welding protection

for piston rod
for swing clamp with welding protection no. 6829W for protection of the piston rod against weld spatter. High-strength aluminium alloy, anodised.



Order no.	Size	dia. A	B	C	D	dia. E	G	J	dia. K	L2	Weight [g]
91645	25	40	14,5	16,4	2,0	12,1	M4	10,5	25	32,0	32
91660	32	50	18,0	22,6	3,8	16,1	M5	11,0	32	41,3	55
91686	40	50	17,9	22,6	3,8	16,1	M6	11,0	32	41,4	58
91702	50	59	33,0	25,8	5,1	20,1	M6	25,0	39	46,5	122
91793	63	69	33,0	25,8	5,1	20,1	M6	25,0	50	59,5	160

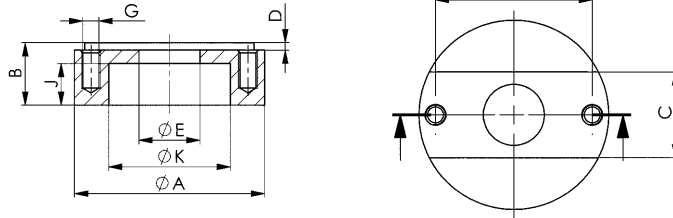

CAD



No. 6829WSP

Clamp arm

for swing clamp with welding protection no. 6829W.
High-strength aluminium alloy, black. HART-COAT® surface for wear-resistance and reduced adhesion of weld spatter.
Ready for mounting, with connection thread for clamping screw no. 6880.



Order no.	Size	C	dia. D	dia. D2	E	F	H	I	L	M	L2	N	dia. W	Weight [g]
91678	25	16	8,3	4,8	16,00	32,0	5,5	14	63,5	M6	32,0	7	12	36
91694	32	22	10,5	5,7	20,70	45,0	9,0	18	80,0	M8	41,3	10	16	83
91751	40	22	10,5	6,4	20,70	45,0	9,0	22	82,0	M8	41,4	10	16	84
91603	50	25	12,5	6,4	23,25	65,0	12,0	25	105,0	M10	46,5	10	20	144
91629	63	25	12,5	6,4	29,75	72,5	12,0	25	120,0	M10	59,5	10	20	168

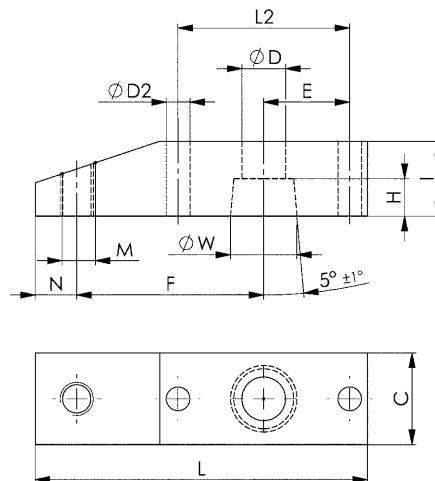

CAD



Subject to technical alterations.

No. 6897S

Sensor monitor

for manual clamps.

For monitoring the closed position of the toggle clamp. Complete with inductive sensor M8x1 for ambient temperatures from 0° to 60° C. Matching plug connection no. 6897K.



Order no.	Size	L x W x H	Weight [g]
90597	3	55 x 40 x 35	60

Note:

Sensor monitor size 3 can be used on both sides for horizontal toggle clamp no. 6830-3, 6834-3 and 6830B-3, only on one side for horizontal toggle clamp with safety latch no. 6830S-3.

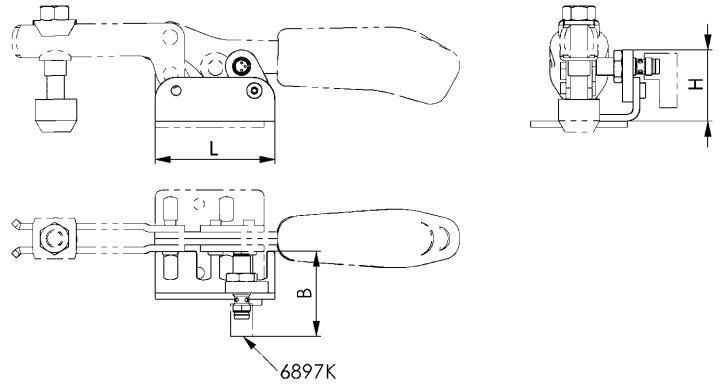

No. 6897K

Plug connection for sensor monitor

for sensor monitor no. 6897S and 6820SIS.

Angled plug connection, cable permanently injection-moulded on.

Order no.	Size	Cable length [m]	Weight [g]
90613	1	2	75
90639	2	5	150

Note:

IP68 acc. to IEC 529, silicone-free, halogen-free, gold-plated contacts.



Subject to technical alterations.

No. 6890

Clamping screw

for open clamping arms, tempered, galvanised and passivated. Strength class 8.8, with removable protective cap made of NBR + NR. The vulcanised compression piece is made of neoprene. Both materials are oil-resistant, silicone-free with a hardness of 70 Shore A and serve to protect sensitive workpieces. Size 0-3, 6 with washer/nut element, size 4-7 with nut for T-slots.

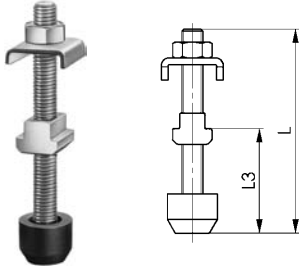

Order no.	Size	Screw DIN 933	T-Nut DIN 508	Washer size	L	L3	Weight [g]
99002	0	M 4x 25	-	0	32	13-20	5
99010	1	M 5x 30	-	1	38	17-24	10
99028	2	M 6x 35	-	2	45	19-28	22
99077	2	M 6x 50	-	2	60	19-43	30
99036	3	M 8x 45	-	3	58	22-34	40
99044	4	M 8x 65	M 8x10	4	78	21-50	62
99051	5	M 8x 65	M 8x10	5	78	21-45	62
561827	6 *	M10x116	-	6	116	28-78	122
99085	6	M12x 80	M12x14	6	97	28-58	160
99069	7	M12x110	M12x14	6	127	28-88	180

* with bonded thrust piece

No. 6890NI

Clamping screw

for open clamping arms, stainless steel. Size 4 with 2 washers. Protective cap made of oil-resistant NBR + NR for protection of sensitive workpieces. Hardness 70 Shore A, silicone-free.

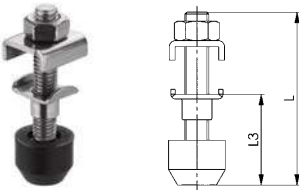

Order no.	Size	Screw DIN 933	Washer size	L	L3	Weight [g]
96040	0	M4x25	0	32	13-20	5
96057	1	M5x30	1	38	17-24	10
96065	2	M6x35	2	45	19-28	22
96073	3	M8x45	3	58	22-34	40
96081	4	M8x65	4	78	21-50	60

Application possibilities, in relation to toggle clamp size:

Article no. of toggle clamps	Size clamping screw									
	0	1	2	3	4	5	6*	6	7	
6800	0	1	2	3	4	-	-	5	6	
6800NI	0	1	2	3	4	-	-	-	-	
6800S / 6802S	-	-	2	3	4	-	-	-	-	
6802	-	1	2	3	4	-	-	5	6	
6803	-	1	2	3	4	-	-	-	-	
6803NI	-	-	2	-	-	-	-	-	-	
6803S	-	-	2	3	4	-	-	-	-	
6820A	-	1	2	3	4	-	-	-	-	
6820P	0	1	2	3	-	-	-	-	-	
6821A	-	-	2	3	4	-	-	-	-	
6830 / 6832	0	1	2	3	4	5	6	-	-	
6830NI	0	1	2	3	4	-	-	-	-	
6830S / 6832S	-	-	-	3	4	-	-	-	-	
6833	-	1	2	3	4	-	-	-	-	
6837M	-	-	2	3	4	-	-	-	-	
6895	0	1	2	3	4	5	-	6	-	

No. 6890C

Clamping screw

for comfortline vertical toggle clamp, tempered, galvanised and passivated. Strength class 8.8, with removable protective cap made of oil-resistant NBR + NR for protection of sensitive workpieces. Hardness 70 Shore A, silicone-free.

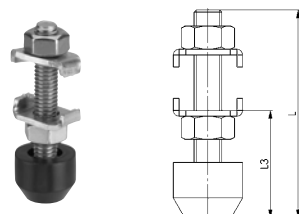

Order no.	Size	Screw DIN 933	Washer size	L	L3	Weight [g]
565898	1	M5 x 30	1	38	16 - 23	13
565899	2	M6 x 35	2	45	19 - 27	22

Subject to technical alterations.

No. 68301

Clamping screw

For horizontal acting toggle clamp plus.

complete with U-washers, hex nuts and screw with bonded pressure pad, made of oil-resistant neoprene to prevent damage to delicate workpieces. Hardness 85 Shore A, silicone-free. Strength class 8.8.

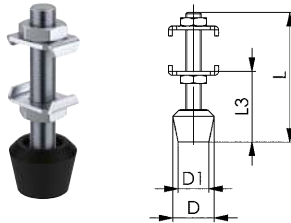

Order no.	Size	M x L	D	D1	L3	Weight [g]
552698	1	M5 x 35	11	10	9 - 18	15
551718	2	M6 x 50	16	12	17 - 29	20
551719	3	M8 x 58	21	16	21 - 34	36
551720	4	M10 x 76	26	20	28 - 44	95

No. 68301NI

Clamping screw

for horizontal toggle clamp plus, stainless steel.

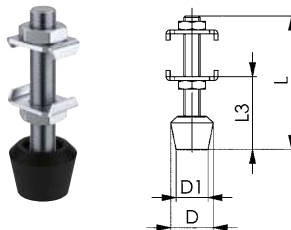

Order no.	Size	M x L	D	D1	L3	Weight [g]
560014	1	M5 x 35	11	10	10 - 22	15
555177	2	M6 x 50	16	12	17 - 29	20
558996	3	M8 x 58	21	16	22 - 31	45
555178	4	M10 x 76	26	20	28 - 44	95

No. 6890B

Clamping screw, black

for open clamping arms,

matte-black galvanized, complete with washer, nut element, washer, hex nut and screw with bonded pressure pad, made of oil-resistant neoprene to prevent damage to delicate workpieces. Hardness 85 Shore A, silicone-free. Strength class 8.8.

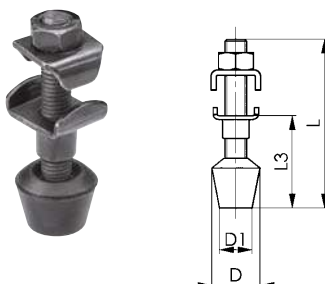

Order no.	Size	M x L	D	D1	L3	Weight [g]
99614	0	M4x34,5	10	-	11,5-22	6
99671	1	M5x38,0	13	10	17,0-24	11
99630	2	M6x46,0	16	10	20,0-27	17
92635	2	M6x60,0	16	10	20,0-40	22
92916	2	M6x110,0	16	10	20,0-90	60
99655	3	M8x63,0	18	13	27,0-37	39

No. 6875

Clamping screw

for open clamping arms,
galvanised. For auto-adjust toggle clamps.

Order no.	Size	M x L	D	L3	Weight [g]
557079	1	M6 x 49	19	16 - 34	23
557080	2	M8 x 50	27	21 - 31	51
557081	3	M8 x 66	27	21 - 47	55

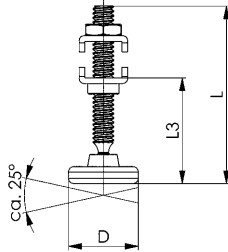

CAD



No. 6876

Clamping screw

for push-pull type toggle clamps,
galvanised. For auto-adjust toggle clamps.

Order no.	Size	M x L	D	L3	Weight [g]
557086	1	M6 x 37	19	13 - 25	16
557087	2	M8 x 50	27	16 - 35	41

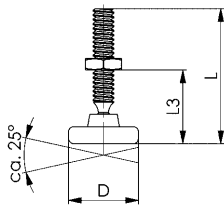

CAD



No. 6880

Clamping screw

For push-pull type toggle clamps,
tempered, galvanised and passivated. Strength class 8.8,
with nut and removable protective cap made of oil-resistant NBR
+ NR for protection of sensitive workpieces. Hardness 70 Shore A,
silicone-free.

Order no.	Size	Screw DIN 933	L	L3	Weight [g]
98012	0+1	M 4x20	27	12-20	4
98038	2	M 6x25	35	17-25	15
98046	3	M 8x35	48	22-35	26
98053	5	M10x50	66	30-52	57
98061	7	M12x50	68	30-50	82
98475	8	M16x80	90	25-70	220

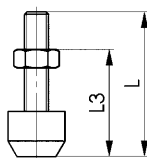

CAD



Subject to technical alterations.

No. 6880NI

Clamping screw

for push-pull type clamps,
stainless steel

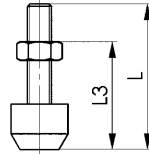

Order no.	Size	Screw DIN 933	L	L3	Weight [g]
96008	0+1	M 4x20	27	12-20	4
96016	2	M 6x25	35	18-27	15
96024	3	M 8x35	48	22-35	26
96032	7	M12x50	68	30-50	82

CAD



No. 6885

Clamping screw

For massive and fixed clamping arms,
tempered, galvanised and passivated. Strength class 8.8,
with two nuts and removable protective cap made of oil-resistant
NBR + NR.

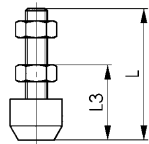

Order no.	Size	Screw DIN 933	L	L3	Weight [g]
98517	1	M 5x 30	38	14-25	10
98525	2	M 6x 35	45	17-25	20
98533	3	M 8x 45	58	22-32	35
98541	4	M 8x 65	78	22-52	40
98558	5	M12x 80	98	30-60	130
98566	6	M12x110	128	30-88	160
98582	8	M16x120	130	25-84	280

CAD



No. 6880B

Clamping screw, black

for push-pull type clamps,
matte-black, with nut and bonded pressure pad,
strength class 8.8.

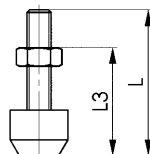

Order no.	Size	Screw DIN 933	L	L3	Weight [g]
99622	1	M4 x 20	23	10-17	4
99705	2	M6 x 25	35	17-25	15
492058	3	M8 x 44	44	26 - 33	26

CAD



No. 6894

Clamping screw

with a bonded pressure pad, made of oil resistant neoprene to prevent damage to delicate workpieces. Hardness 85 Shore A, silicone-free. Screw tempered, galvanized and passivated, strength class 8.8.

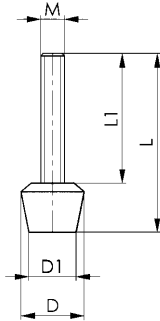

Order no.	M x L	D	D1	L1	Weight [g]
99408	M 4x 32	11	8	24	4
99416	M 5x 38	13	10	28	8
99390	M 6x 35	16	12	23	11
99424	M 6x 45	16	12	33	13
99556	M 6x 60	16	12	48	16
99432	M 8x 48	21	16	32	25
99499	M 8x 58	21	16	42	29
99440	M 8x 63	21	16	47	31
99457	M 8x 78	21	16	62	37
99580	M10x 66	26	20	46	53
99598	M10x 76	26	20	56	59
99606	M10x116	26	20	96	84
99465	M12x 70	31	24	46	78
99473	M12x100	31	24	76	105
99481	M12x130	31	24	106	131

CAD



No. 6891

Self-aligning clamping screw

for open clamping arms, tempered, galvanized and passivated. Sizes 1-3 with washer/ nut-element. Sizes 4-6 with T-nut.

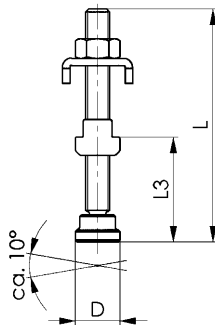

Order no.	Size	Screw DIN 6332	T-Nut DIN 508	Washer size	D	L	L3	Weight [g]
99119	1	M 5x 35	-	1	12	37	12-22	12
99127	2	M 6x 50	-	2	12	52	14-33	20
99135	3	M 8x 75	-	3	16	78	18-52	47
99143	4	M 8x 75	M 8x10	4	16	78	15-50	62
99168	6	M12x100	M12x14	6	25	105	25-62	183

CAD



No. 6886

Self-aligning clamping screw

for solid and closed clamping arms, tempered, galvanized and passivated.

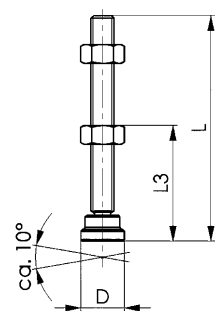

Order no.	Size	Screw DIN 6332	D	L	L3	Weight [g]
98616	1	M 5x 35	12	37	8-23	9
98632	4	M 8x 75	16	78	16-52	42
98665	6	M12x100	25	105	30-61	138

CAD





CONVENIENT ORDERING – IN OUR ONLINE SHOP

- + Over 6000 products can be ordered online
- + Order tracking online
- + Easy download of CAD data
- + Online inquiry of availability
- + Management of different shopping carts

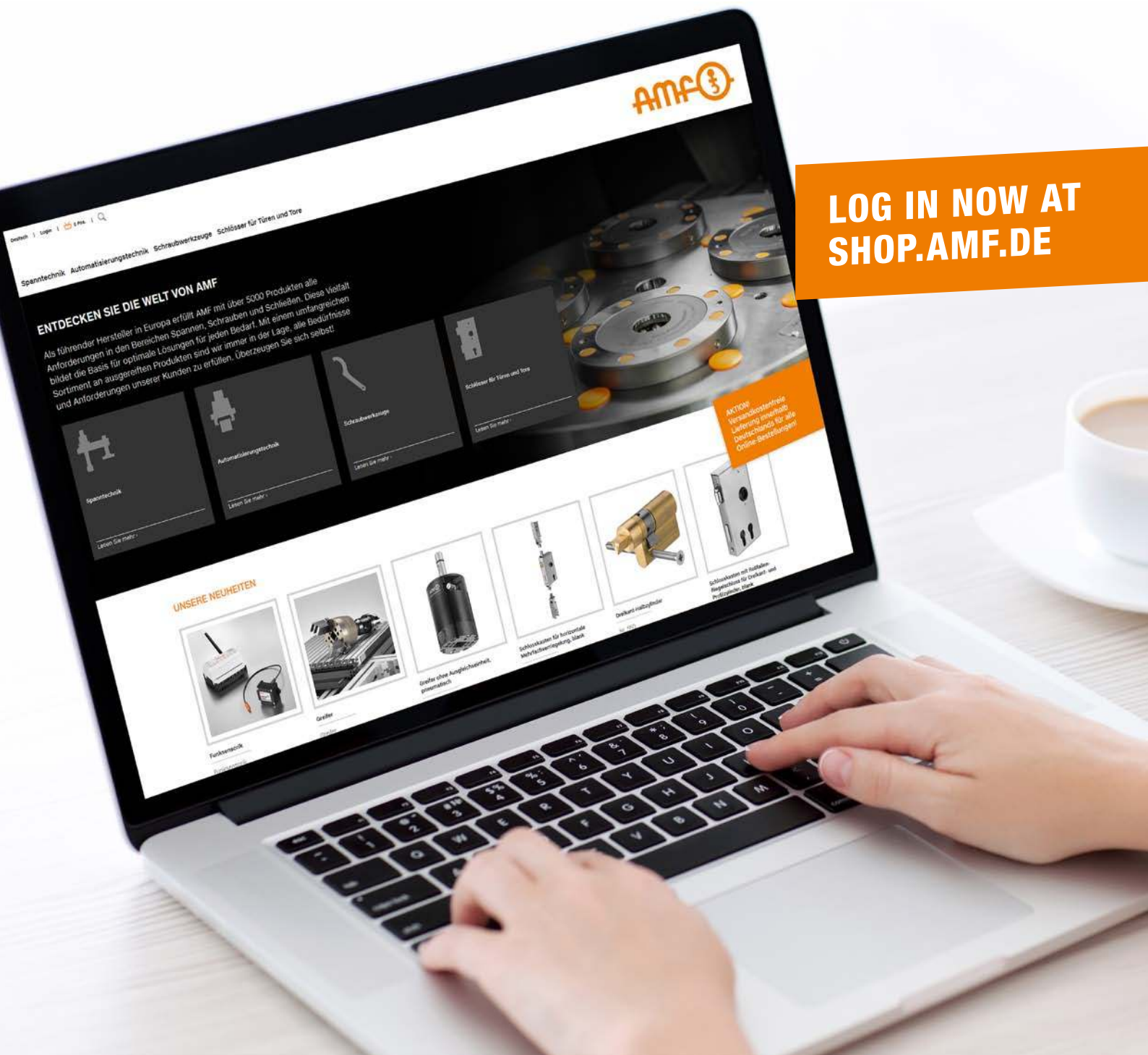

LOG IN NOW AT
SHOP.AMF.DE

No. 6892

Spring loaded screw

for open ended clamping arms,
tempered, galvanized and passivated.



Order no.	Size	B	G	G1	Rubber nose	L	L3	L4	Weight [g]
99259	3	14,5	M 8	M5	6893-M5	90	39-52	5	55
99267	4	18,5	M 8	M5	6893-M5	90	40-53	5	63
99275	5	20,5	M 8	M5	6893-M5	90	40-48	5	64
99283	6	24,0	M12	M8	6893-M8	123	60-68	7	182

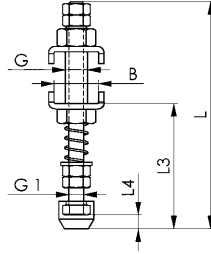

Spring rate:

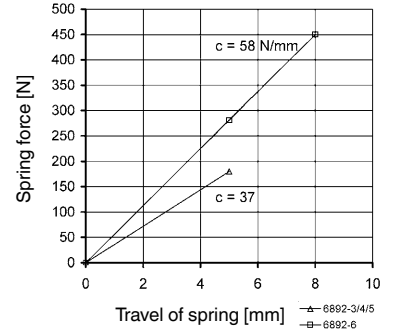

CAD



No. 6887

U-washer

galvanised and passivated.
For clamping screws 6890.

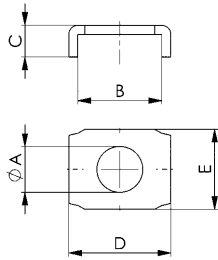

Order no.	Size	dia. A	B	C	D	E	Weight [g]
557062	0	4,2	8,1	3,0	10,6	9	1
557074	1+2	6,3	11,5	4,4	14,0	11	2
557075	3	8,5	14,6	7,2	18,6	20	7
564052	4	8,5	18,5	8,4	23,5	20	12
564053	5	8,5	20,5	7,4	25,5	20	12
564054	6	13,0	24,0	9,4	30,0	30	24

CAD



No. 6887B

U-washer

matte-black.
For clamping screws 6890B.

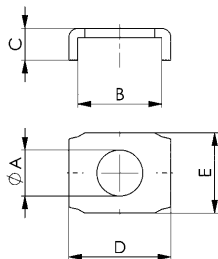
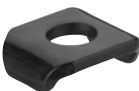

Order no.	Size	dia. A	B	C	D	E	Weight [g]
564055	0	4,2	8,1	3,0	10,6	9	1
557076	1+2	6,3	11,5	4,4	14,0	11	2
557077	3	8,5	14,6	7,2	18,6	20	7

Application possibilities, in relation to toggle clamp size:

Article no. of toggle clamps	Size U-washer 6887 / 6887B					
	0	1+2	3	4	5	6
6800	0	1+2	3	4	-	5+6
6800S / 6802S	-	2	3	4	-	-
6802	-	1+2	3	4	-	5+6
6803	-	1+2	3	4	-	-
6803S	-	2	3	4	-	-
6820A	-	1+2	3	4	-	-
6820P	0	1+2	3	-	-	-
6821A	-	2	3	4	-	-
6830 / 6832	0	1+2	3	4	5	-
6830S / 6832S	-	-	3	4	-	-
6833	-	1+2	3	4	-	-
6837M	-	2	3	4	-	-
6895	0	1+2	3	4	5	6

CAD



Subject to technical alterations.

No. 6893

Rubber nose

Made of oil resistant neoprene to prevent damage to delicate components. Hardness 70 Shore A. Fits the clamping screws no. 6880, no. 6885, no. 6890 and no. 6892, for placement on hexagon screw head ISO 272. Minimum order quantity is 10 pieces per size.



Order no.	Size	SW	D	D1	H	H1	Weight [g]
99309	M 4	7	11,0	7	8,5	4,2	1
99325	M 5	8	12,5	8	10,0	5,0	1
99333	M 6	10	15,0	10	12,0	6,0	2
99341	M 8	13	19,0	13	15,0	7,5	4
99358	M10	16	22,0	15	17,5	8,5	5
99374	M12-SW18	18*	25,0	18	20,0	9,5	8
99366	M12-SW19	19**	26,0	19	20,0	9,5	9
99382	M16	24	33,0	24	27,0	14,0	19

* According to new standard ISO 4017 (marked with a „6“ on its clamping face).
 ** According to old norm DIN 933.

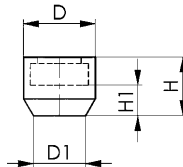

No. 6899

Clamping arm extension

for manual clamps, Aluminium. Complete with fastening bolt. Without clamping screw.



Order no.	Size	A	B	E	I	L	SW	Weight [g]
557094	1	5 x M5	6	12	11	61	7	24
557095	2	6 x M6	8	15	14	90	8	47
557096	3	8 x M8	3	15	17	115	10	92

Note:

Can be shortened to desired length.

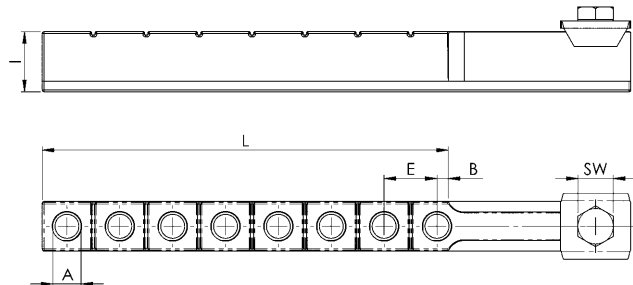

No. 6896

Clamping arm extension

for manual clamps, steel, blued. Complete with fastening screw. Without clamping screw.



Order no.	Size	Clamping screw	A	E	I	L	SW	Weight [g]
94045	0	M4	4,2	25	10	32,5	7	15
94060	1	M5	5,2	45	12	55,0	8	25
94086	2	M6	6,2	65	14	73,5	10	40
94102	3	M8	8,2	70	20	82,0	13	80

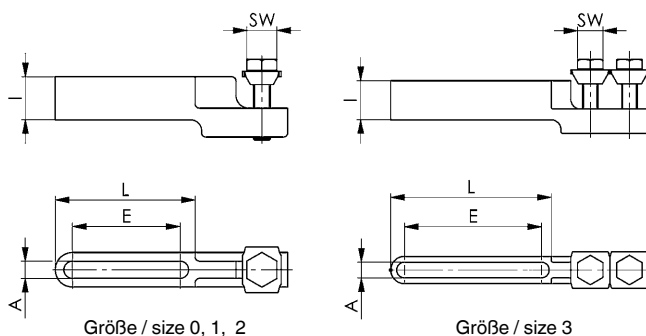

Subject to technical alterations.

No. 6878K

Clamping bolt for perforated tables

For adapting toggle clamps on perforated tables for woodworking and welding.

The toggle clamp can be fixed quickly and easily from above. The clamping bolt is insensitive to the surface quality and diameter of the hole and can also be used with thin plates from 4 mm.

Order no.	Size	Cylinder screw ISO 4762	dia. D	H	Weight [g]
564126	16	M8 x 20	16	17,5	36
564127	20	M8 x 25	20	20,0	59
564128	28	M8 x 30	28	28,5	148

Design:

- Area of application woodworking size 20: Stainless steel
- Area of application welding sizes 16 and 28: burnished steel

Note:

The toggle clamp is attached using the supplied cylinder screw.

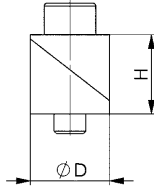

Recommendations



No. 6870F,
page 106



No. 6878AE,
page 174



No. 6878AR,
page 174

No. 6878RM

Rhombus T-slot adapter

For adapting toggle clamps on T-slot tables. Suitable for woodworking and welding.

The rhombus T-nut with integrated inhibition can be easily and conveniently inserted in the desired position from above into the T-slot and screwed tightly. Rhombus nut made of tempered steel, burnished.

Including screw set for mounting various toggle clamps and adapter plates.

Order no.	Slot	Weight [g]
564235	12	40
564236	14	50
564237	16	70
564238	18	90



Recommendations



No. 6870F,
page 106



No. 6878AR,
page 174



No. 6830,
page 32



Application possibilities, in relation to toggle clamp size:

Article no. of toggle clamps	Size	Only clamping bolt or rhombus T-slot adapter without adapter plate	Size mounting kit 6878B for adapter plate round and angular		
			M5	M6	M8
6800	2		●		
	3			●	
	4				●
6830	2		●		
	3			●	
	4				●
6870F	20		●		
	50	●		●	
	70	●		●	
6874F	15		●		
	25	●		●	

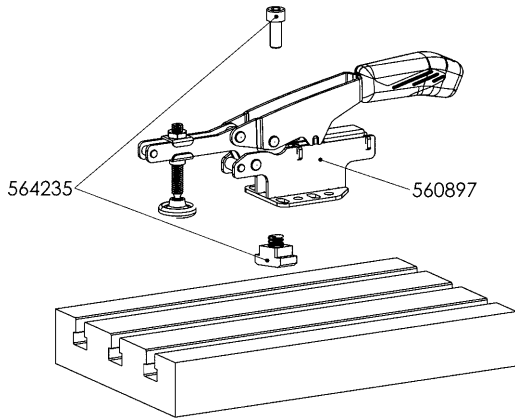

No. 6878AE

Adapter plate, angular

For fastening vertical toggle clamps and horizontal toggle clamps on perforated tables for woodworking and welding. Particularly suitable for quick positioning. The toggle clamp can be fixed quickly and easily from above. Steel adapter plate, galvanized and passivated.



Order no.	Size	Flat-head screw DIN 7991	N	P	Weight [g]
564129	1	M8 x 35	62	93	170

Note:

The adapter plate is fastened on the perforated table using the corresponding clamping bolt. The toggle clamp is attached on the adapter by flat-head screws from below. For this purpose, select the required mounting kit 6878B according to the toggle clamp sizes.

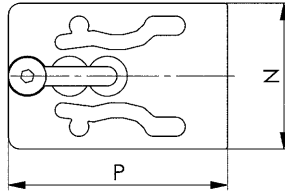

CAD



No. 6878AR

Adapter plate, round

For fastening vertical toggle clamps and horizontal toggle clamps on perforated tables for woodworking and welding. For flexible change of position within the breadboard. Steel adapter plate, galvanized and passivated. Clamping bolt with washer for fixing the round adapter plate on the perforated table.



Order no.	Size	dia. D1	dia. D2	P	Weight [g]
564130	1	145	100	140	450

Note:

To fix the adapter plate round with the clamping bolts 6878K on the perforated table, the mounting kit discs, order no. 564139 are required.

The toggle clamp is attached on the adapter plate by flat-head screws from below. For this purpose, the mounting kit 6878B according to the toggle clamp sizes is required.

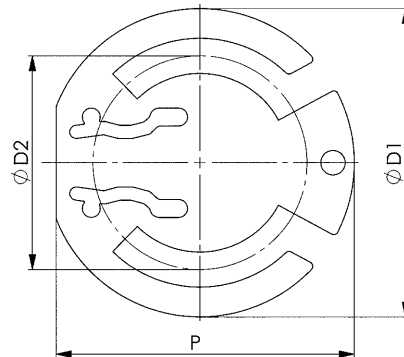

CAD



Application examples:

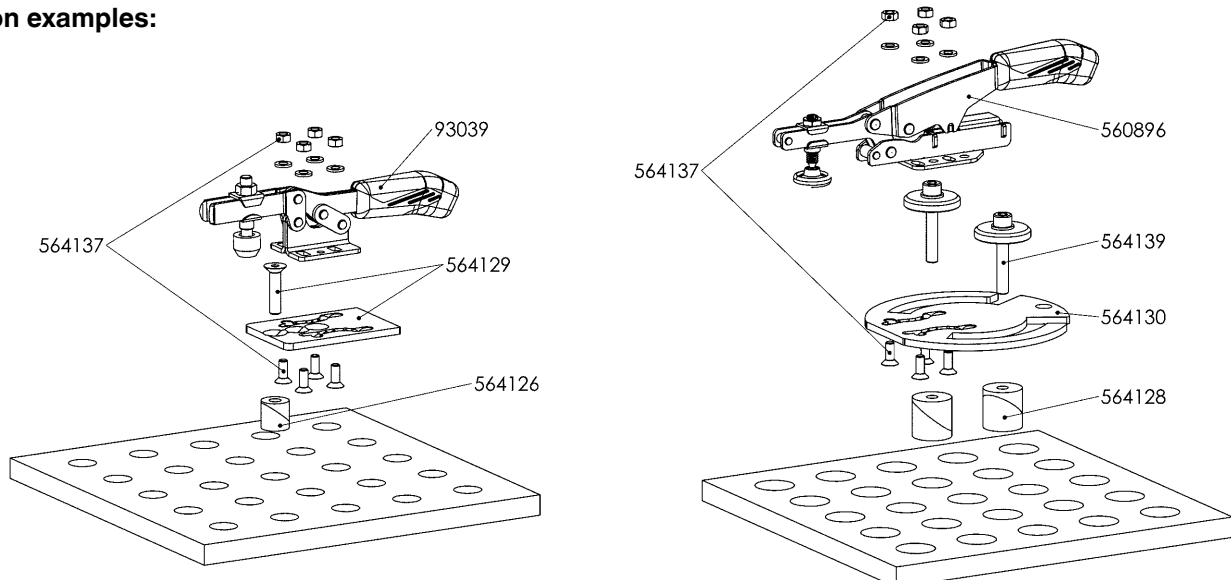

Subject to technical alterations.



Subject to technical alterations.

No. 6878B

Mounting kit

For adapter plates 6878AE and 6878AR.

- Supplied as standard:
- 4 x flat-head screws
 - 4 x washers
 - 4 x nuts



Order no.	Size	Weight [g]
564136	M5	4
564137	M6	6
564138	M8	9

No. 6878S

Mounting kit, disc

For adapter plate round 6878AR.

- Supplied as standard:
- 1 x disc
 - 1 x washers
 - 1 x cylinder screw

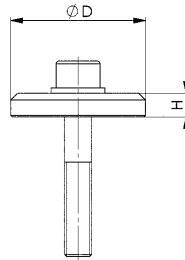

Order no.	Size	Cylinder screw ISO 4762	D	H	Weight [g]
564139	1	M8 x 50	40	7	100

CAD



No. 6877

Adapter for perforated tables Ø 19 mm

Aluminium.

Adapter for fastening the auto-adjust toggle clamps on perforated tables.

Fastening the adapter onto the toggle clamps by a screw and hole at the foot of the toggle clamp.

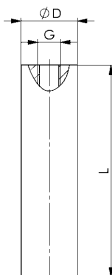

Order no.	Size	dia. D	L	G	Weight [g]
558988	1	19	76,0	M8	60
558989	2	19	190,5	M8	150

On request:

Other sizes with Ø 20 mm available on request.

CAD



Subject to technical alterations.



Subject to technical alterations.

No. 6895

Supporting arm for toggle clamps

Galvanized and passivated, complete with two tempered clamping screws no. 6890 and fastening screw.

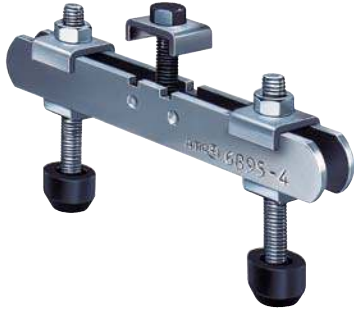

Order no.	Size	Screw DIN 933	Distance between screws	Length	Weight
				[mm]	[g]
99507	0	M 4x25	18- 60	70	40
99515	1	M 5x30	22- 72	85	65
99523	2	M 6x35	28- 85	100	90
99531	3	M 8x45	34-100	120	200
99549	4	M 8x65	40-125	150	370
99572	5	M 8x65	40-125	150	370
99564	6	M12x80	54-200	240	985

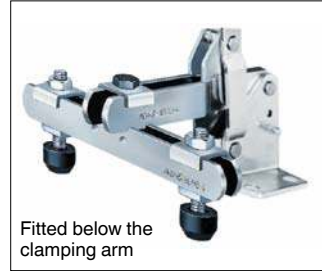
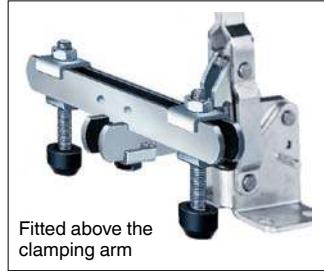

Application possibilities, in relation to toggle clamp size:

Article no. of toggle clamps	Size of supporting arm						
	0	1	2	3	4	5	6
6800	0	1	2	3	4	-	5+6
6800S/6802S	-	-	2	3	4	-	-
6802	-	1	2	3	4	-	-
6803	-	1	2	3	4	-	-
6803S	-	-	2	3	4	-	-
6820A	-	1	2	3	4	-	-
6820P	0	1	2	3	-	-	-
6821A	-	-	2	3	4	-	-
6830/6832	0	1	2	3	4	5	-
6830S/6832S	-	-	-	3	4	-	-
6833	-	1	2	3	4	-	-



No. 6820SIS

Proximity switch



Order no.	Cable length	Weight
	[m]	[g]
392241	0,3	15

Application:

Proximity switch for end-position sensing.

Note:

PUR cable 0.3 m with M8 plug connection and rotating knurled nuts.
Switching function: NOC.
Output: PNP.

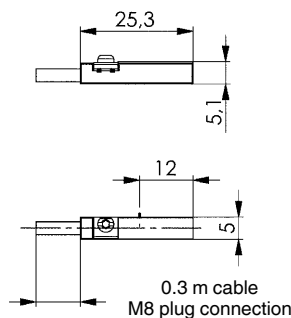

Subject to technical alterations.

No. 6848GH

Counter catch

for no. 6848H.
Galvanized and passivated.

Order no.	Size	C1	D	H	H1	K	L	N	Weight [g]
94821	2	11	5,2	12	18	8	26	18	16
94839	3	14	6,5	19	28	12	39	23	44
94847	4	19	8,5	26	38	17	56	30	108



No. 6848GHNI

Counter catch

for no. 6848HNI.
Polished stainless steel.



Order no.	Size	C1	D	H	H1	K	L	N	Weight [g]
95638	2	11	5,2	12	18	8	26	18	16
95646	3	14	6,5	19	28	12	39	23	44
95653	4	19	8,5	26	38	17	56	30	108

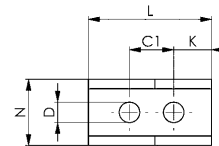
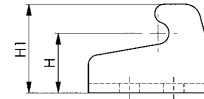

No. 6848GV

Counter catch

for no. 6848V.
Galvanized and passivated.

Order no.	Size	C1	D	H	H1	K	L	N	Weight [g]
94854	2	11	5,2	5	12	5	26	18	14
94862	3	14	6,5	6	14	7	36	23	30
94870	4	19	8,5	8	22	9	48	30	66



No. 6848GVNI

Counter catch

for no. 6848VNI.
Polished stainless steel.



Order no.	Size	C1	D	H	H1	K	L	N	Weight [g]
95661	2	11	5,2	5	12	5	26	18	14
95679	3	14	6,5	6	16	7	36	23	30
95687	4	19	8,5	8	22	9	48	30	66

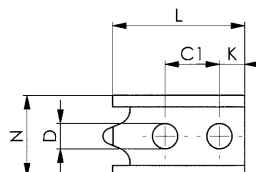
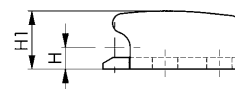

Subject to technical alterations.

... BY ITEM NO.

Article no.	Page	Article no.	Page	Article no.	Page	Article no.	Page	Article no.	Page
No. 6800	12	No. 6805E	24	No. 68300E	34	No. 6841E	46	No. 6848HSNIJ	100
No. 6800B	118	No. 6805G	25	No. 68300G	35	No. 6841G	47	No. 6848HSNIT	101
No. 6800BS	125	No. 6805J	24	No. 68300J	34	No. 6841J	46	No. 6848HSNIY	100
No. 6800C	15	No. 6805T	25	No. 68300NI	90	No. 6841NI	92	No. 6848HST	83
No. 6800E	12	No. 6805Y	24	No. 68300NIE	90	No. 6841NIE	92	No. 6848HSY	82
No. 6800ESD	112	No. 6806	22	No. 68300NIG	91	No. 6841NIG	93	No. 6848HT	61
No. 6800G	13	No. 6806E	22	No. 68300NIJ	90	No. 6841NIJ	92	No. 6848HY	60
No. 6800J	12	No. 6806G	23	No. 68300NIT	91	No. 6841NIT	93	No. 6848V	62
No. 6800NI	84	No. 6806J	22	No. 68300NIY	90	No. 6841NIY	92	No. 6848VE	62
No. 6800NIE	85	No. 6806T	23	No. 68300T	35	No. 6841T	47	No. 6848VG	63
No. 6800NIG	85	No. 6806Y	22	No. 68300Y	34	No. 6841Y	46	No. 6848VJ	62
No. 6800NIJ	84	No. 6809G	31	No. 68301	165	No. 6842	54	No. 6848VNI	102
No. 6800NIT	85	No. 6809H	30	No. 68301NI	165	No. 6842E	54	No. 6848VNIE	102
No. 6800NIY	84	No. 6809P	28	No. 6832	36	No. 6842G	55	No. 6848VNIG	103
No. 6800S	66	No. 6809RK	30	No. 6832B	121	No. 6842J	54	No. 6848VNIJ	102
No. 6800SE	67	No. 6809RL	30	No. 6832BS	127	No. 6842PK	56	No. 6848VNIT	103
No. 6800SG	67	No. 6809S	31	No. 6832E	36	No. 6842PL	57	No. 6848VNIY	102
No. 6800SJ	66	No. 6809V	31	No. 6832G	37	No. 6842T	55	No. 6848VT	63
No. 6800ST	67	No. 6810P	29	No. 6832J	36	No. 6842Y	54	No. 6848VY	62
No. 6800SY	66	No. 6811P	26	No. 6832S	76	No. 6843	52	No. 6849PH	64
No. 6800T	13	No. 6812P	27	No. 6832SE	76	No. 6843NI	95	No. 6850A	134
No. 6800Y	12	No. 6820A	138	No. 6832SG	77	No. 6844	50	No. 6860	44
No. 6802	16	No. 6820P	137	No. 6832SJ	76	No. 6844E	50	No. 6860E	45
No. 6802B	119	No. 6820SIS	178	No. 6832ST	77	No. 6844ESD	115	No. 6860G	45
No. 6802BS	126	No. 6821A	139	No. 6832SY	76	No. 6844G	51	No. 6860J	44
No. 6802E	16	No. 6825A	140	No. 6832T	37	No. 6844J	50	No. 6860P	135
No. 6802G	17	No. 6825CE	141	No. 6832Y	36	No. 6844NI	94	No. 6860T	45
No. 6802J	16	No. 6826A	142	No. 6833	38	No. 6844NIE	94	No. 6860Y	44
No. 6802S	68	No. 6828H	149	No. 6833E	38	No. 6844NIG	95	No. 6870F	106
No. 6802SE	68	No. 6828M	148	No. 6833G	39	No. 6844NIJ	94	No. 6871	107
No. 6802SG	69	No. 6828SP	153	No. 6833J	38	No. 6844NIT	95	No. 6872	108
No. 6802SJ	68	No. 6828U	152	No. 6833T	39	No. 6844NIY	94	No. 6873	110
No. 6802ST	69	No. 6829AD	159	No. 6833Y	38	No. 6844T	51	No. 6874F	109
No. 6802SY	68	No. 6829BR/BL	156	No. 6834	40	No. 6844Y	50	No. 6875	166
No. 6802T	17	No. 6829ER/EL	158	No. 6834E	40	No. 6845	52	No. 6876	166
No. 6802Y	16	No. 6829GF	160	No. 6834G	41	No. 6845B	124	No. 6877	176
No. 6803	18	No. 6829KR/KL	155	No. 6834J	40	No. 6847	58	No. 6878AE	174
No. 6803E	18	No. 6829L	146	No. 6834S	78	No. 6847G	58	No. 6878AR	174
No. 6803G	19	No. 6829LA	147	No. 6834SE	78	No. 6847GK	59	No. 6878B	176
No. 6803J	18	No. 6829N	160	No. 6834SG	79	No. 6847GKNI	97	No. 6878K	172
No. 6803NI	86	No. 6829SP	159	No. 6834SJ	78	No. 6847GNI	96	No. 6878RM	172
No. 6803NIE	86	No. 6829V	144	No. 6834ST	79	No. 6847K	59	No. 6878S	176
No. 6803NIG	87	No. 6829VA	145	No. 6834SY	78	No. 6847KNI	97	No. 6880	166
No. 6803NIJ	86	No. 6829WR/WL	161	No. 6834T	41	No. 6847NI	96	No. 6880B	167
No. 6803NIT	87	No. 6829WS	162	No. 6834Y	40	No. 6847S	81	No. 6880ESD	116
No. 6803NIY	86	No. 6829WSP	162	No. 6835BO	129	No. 6847SU	81	No. 6880NI	167
No. 6803S	70	No. 6830	32	No. 6835BS-2	128	No. 6848GH	179	No. 6885	167
No. 6803SE	70	No. 6830B	120	No. 6835BS-3	130	No. 6848GHNI	179	No. 6886	168
No. 6803SG	71	No. 6830E	32	No. 6835B-2	122	No. 6848GV	179	No. 6887	170
No. 6803SJ	70	No. 6830ESD	113	No. 6835B-3	123	No. 6848GVNI	179	No. 6887B	170
No. 6803ST	71	No. 6830G	33	No. 6837H	42	No. 6848H	60	No. 6889	164
No. 6803SY	70	No. 6830J	32	No. 6837HE	43	No. 6848HE	60	No. 6890B	165
No. 6803T	19	No. 6830NI	88	No. 6837HG	43	No. 6848HG	61	No. 6890C	164
No. 6803Y	18	No. 6830NIE	88	No. 6837HJ	43	No. 6848HJ	60	No. 6890ESD	116
No. 6804	20	No. 6830NIG	89	No. 6837HT	43	No. 6848HNI	98	No. 6890NI	164
No. 6804E	20	No. 6830NIJ	88	No. 6837HY	42	No. 6848HNIE	98	No. 6891	168
No. 6804G	21	No. 6830NIT	89	No. 6837M	42	No. 6848HNIG	99	No. 6892	170
No. 6804J	20	No. 6830NIY	88	No. 6840	48	No. 6848HNIJ	98	No. 6893	171
No. 6804S	72	No. 6830S	74	No. 6840E	48	No. 6848HNIT	99	No. 6894	168
No. 6804SE	72	No. 6830SE	74	No. 6840ESD	114	No. 6848HNIY	98	No. 6895	178
No. 6804SG	73	No. 6830SG	75	No. 6840G	49	No. 6848HS	82	No. 6896	171
No. 6804SJ	72	No. 6830SJ	74	No. 6840J	48	No. 6848HSE	82	No. 6897K	163
No. 6804ST	73	No. 6830ST	75	No. 6840S	80	No. 6848HSG	83	No. 6897S	163
No. 6804SY	72	No. 6830SY	74	No. 6840T	49	No. 6848HSJ	82	No. 6899	171
No. 6804T	21	No. 6830T	33	No. 6840Y	48	No. 6848HSNI	100		
No. 6804Y	20	No. 6830Y	32	No. 6841	46	No. 6848HSNIE	100		
No. 6805	24	No. 68300	34	No. 6841B	124	No. 6848HSNIG	101		

... BY ORDER NO.

Order no.	Page	Order no.	Page	Order no.	Page	Order no.	Page	Order no.	Page
392241	178	557074	170	557213	84	557353	38	557466	13
456400	121	557075	170	557214	84	557357	43	557467	13
482471	121	557076	170	557215	84	557358	43	557468	13
482497	121	557077	170	557216	84	557359	43	557469	13
492058	167	557079	166	557217	84	557360	44	557470	13
551715	34	557080	166	557273	86	557361	44	557471	13
551716	34	557081	166	557274	88	557362	44	557472	17
551717	34	557086	166	557275	88	557373	46	557473	17
551718	165	557087	166	557276	88	557374	46	557474	17
551719	165	557094	171	557277	88	557375	46	557475	17
551720	165	557095	171	557278	88	557376	46	557476	17
552552	34	557096	171	557279	90	557377	46	557477	17
552698	165	557097	36	557280	90	557378	46	557479	19
554881	107	557098	36	557281	98	557389	48	557480	19
554882	107	557099	36	557282	98	557390	48	557481	19
554883	108	557100	36	557283	98	557391	48	557482	19
554884	108	557101	36	557284	100	557392	48	557483	21
554885	110	557102	36	557285	102	557393	48	557484	21
554886	110	557106	40	557286	102	557394	48	557485	21
555061	138	557108	40	557287	102	557397	50	557486	21
555062	138	557109	40	557288	92	557398	50	557487	23
555063	138	557110	40	557289	94	557399	50	557488	23
555064	138	557118	38	557290	94	557400	50	557489	23
555065	139	557119	38	557291	94	557403	54	557490	23
555066	139	557120	38	557301	12	557404	54	557491	25
555067	139	557121	38	557302	12	557405	60	557492	33
555083	149	557125	42	557303	12	557406	60	557493	33
555084	149	557126	42	557304	12	557407	60	557494	33
555085	149	557127	42	557305	12	557408	62	557495	33
555170	149	557143	44	557306	12	557409	62	557496	33
555171	149	557144	44	557307	12	557411	62	557497	33
555172	149	557145	44	557310	16	557417	66	557498	35
555175	90	557147	46	557311	16	557418	66	557499	35
555176	90	557148	46	557312	16	557419	66	557500	35
555177	165	557149	46	557313	16	557420	68	557501	37
555178	165	557150	46	557314	16	557421	68	557502	37
557009	12	557151	46	557315	16	557422	68	557503	37
557010	12	557152	46	557318	18	557423	70	557504	37
557011	12	557161	48	557319	18	557424	70	557505	37
557012	12	557162	48	557320	18	557425	70	557506	37
557013	12	557163	48	557321	18	557426	72	557507	41
557014	12	557164	48	557322	20	557427	74	557508	41
557015	12	557165	48	557323	20	557428	74	557509	41
557018	16	557166	48	557324	20	557429	76	557510	41
557019	16	557167	50	557325	20	557430	76	557511	39
557020	16	557168	50	557326	22	557431	78	557512	39
557021	16	557169	50	557327	22	557432	82	557513	39
557022	16	557170	50	557328	22	557433	84	557514	39
557023	16	557171	54	557329	22	557434	84	557525	43
557024	18	557172	54	557330	24	557435	84	557526	43
557025	18	557173	60	557331	32	557436	84	557527	43
557026	18	557174	60	557332	32	557437	84	557528	45
557027	18	557175	60	557333	32	557438	86	557529	45
557028	20	557176	62	557334	32	557439	88	557530	45
557029	20	557177	62	557335	32	557440	88	557531	47
557030	20	557178	62	557336	32	557441	88	557532	47
557031	20	557179	66	557337	34	557442	88	557533	47
557032	22	557180	66	557338	34	557443	88	557534	47
557033	22	557181	66	557339	34	557444	90	557535	47
557034	22	557182	68	557340	36	557445	90	557536	47
557035	22	557183	68	557341	36	557446	98	557537	49
557037	24	557184	68	557342	36	557447	98	557538	49
557038	32	557202	70	557343	36	557448	98	557539	49
557039	32	557203	70	557344	36	557449	100	557540	49
557040	32	557204	70	557345	36	557450	102	557541	49
557041	32	557205	72	557346	40	557451	102	557542	49
557042	32	557206	74	557347	40	557452	102	557548	51
557043	32	557207	74	557348	40	557453	92	557549	51
557046	34	557209	76	557349	40	557454	94	557550	51
557047	34	557210	76	557350	38	557455	94	557551	51
557048	34	557211	78	557351	38	557456	94	557561	55
557062	170	557212	82	557352	38	557465	13	557562	55

Order no.	Page	Order no.	Page	Order no.	Page	Order no.	Page	Order no.	Page
557563	61	557657	32	557761	88	558028	45	559772	142
557564	61	557658	32	557762	88	558029	45	559773	142
557565	61	557659	32	557763	88	558030	45	559774	142
557566	63	557660	32	557764	88	558031	47	559791	137
557567	63	557668	34	557765	90	558032	47	559792	137
557568	63	557669	34	557766	90	558033	47	559793	137
557569	67	557670	34	557767	98	558034	47	559794	137
557570	67	557671	36	557768	98	558035	47	560007	134
557571	67	557672	36	557769	98	558036	47	560008	134
557572	69	557673	36	557770	100	558037	49	560009	134
557573	69	557674	36	557771	102	558038	49	560010	155
557574	69	557675	36	557772	102	558039	49	560011	155
557575	71	557676	36	557773	102	558040	49	560012	155
557576	71	557678	40	557774	92	558041	49	560013	90
557577	71	557679	40	557775	94	558042	49	560014	165
557578	73	557680	40	557776	94	558046	51	560018	155
557579	75	557681	40	557777	94	558047	51	560019	155
557580	75	557682	38	557930	34	558048	51	560020	155
557581	77	557683	38	557935	34	558049	51	560027	158
557582	77	557684	38	557936	35	558054	55	560028	158
557583	79	557685	38	557937	34	558055	55	560029	158
557584	83	557686	43	557963	13	558056	61	560062	158
557586	85	557687	43	557964	13	558057	61	560063	158
557587	85	557688	43	557965	13	558058	61	560064	158
557588	85	557689	45	557966	13	558126	63	560065	160
557589	85	557690	45	557967	13	558127	63	560066	160
557590	85	557691	45	557968	13	558128	63	560067	160
557595	87	557692	46	557969	13	558129	67	560083	160
557596	89	557693	46	557970	17	558130	67	560084	160
557597	89	557694	46	557971	17	558131	67	560085	160
557598	89	557695	46	557972	17	558136	69	560157	90
557599	89	557696	46	557973	17	558137	69	560158	90
557600	89	557697	46	557974	17	558138	69	560159	90
557601	91	557699	48	557975	17	558149	71	560160	90
557602	91	557700	48	557977	19	558150	71	560161	91
557603	99	557701	48	557978	19	558151	71	560162	91
557604	99	557702	48	557979	19	558155	73	560163	90
557605	99	557703	48	557980	19	558156	75	560164	90
557606	101	557704	48	557981	21	558157	75	560165	91
557607	103	557710	50	557982	21	558158	77	560166	91
557608	103	557711	50	557983	21	558159	77	560895	106
557609	103	557712	50	557984	21	558160	79	560896	106
557610	93	557713	50	557985	23	558161	83	560897	106
557611	95	557714	54	557986	23	558164	85	560904	109
557612	95	557715	54	557987	23	558165	85	560905	109
557613	95	557718	60	557988	23	558166	85	561275	32
557615	12	557719	60	557989	25	558167	85	561276	32
557616	12	557720	60	557991	33	558168	85	561277	32
557617	12	557721	62	557992	33	558169	87	561278	32
557618	12	557722	62	557993	33	558170	89	561279	33
557619	12	557723	62	557994	33	558171	89	561280	33
557620	12	557724	67	557995	33	558172	89	561827	164
557621	12	557725	67	557996	33	558173	89	562483	112
557622	16	557726	67	557997	35	558174	89	562484	112
557623	16	557735	68	557998	35	558175	91	562486	112
557624	16	557736	68	557999	35	558176	91	562487	112
557625	16	557737	68	558000	35	558178	99	562488	113
557626	16	557738	70	558010	37	558179	99	562489	113
557627	16	557739	70	558011	37	558180	99	562490	113
557630	18	557740	70	558012	37	558181	101	562491	113
557631	18	557746	72	558013	37	558182	103	562492	114
557632	18	557747	74	558014	37	558183	103	562493	114
557633	18	557748	74	558015	37	558184	103	562494	114
557635	20	557749	76	558017	41	558185	93	562495	114
557636	20	557750	76	558018	41	558186	95	562496	115
557637	20	557751	78	558019	41	558187	95	562497	115
557638	20	557752	82	558020	41	558188	95	562505	145
557650	22	557753	85	558021	39	558985	90	562506	145
557651	22	557754	85	558022	39	558988	176	562507	145
557652	22	557755	85	558023	39	558989	176	562508	145
557653	22	557756	85	558024	39	558996	165	562509	145
557654	24	557757	85	558025	43	559769	140	562598	116
557655	32	557759	86	558026	43	559770	140	562599	116
557656	32	557760	88	558027	43	559771	140	562600	116

Order no.	Page	Order no.	Page	Order no.	Page	Order no.	Page	Order no.	Page
562601	116	90407	72	91413	156	92825	158	93948	42
562602	116	90415	119	91421	156	92833	158	93955	48
562603	116	90423	120	91439	156	92841	158	94003	52
562604	116	90431	20	91447	156	92858	158	94011	52
564052	170	90449	20	91454	156	92866	158	94029	52
564053	170	90456	20	91462	156	92874	158	94037	52
564054	170	90464	20	91470	81	92882	158	94045	171
564055	170	90472	119	91488	135	92890	158	94052	52
564126	172	90480	120	91496	156	92916	165	94060	171
564127	172	90498	119	91504	156	92924	160	94086	171
564128	172	90506	120	91512	156	92932	160	94094	46
564129	174	90514	24	91520	156	92940	160	94102	171
564130	174	90522	120	91538	156	92957	160	94110	46
564132	15	90530	121	91546	156	92973	160	94128	46
564133	15	90548	124	91553	156	93005	32	94136	46
564134	15	90555	22	91561	156	93013	32	94144	42
564136	176	90563	22	91579	161	93021	32	94151	46
564137	176	90571	22	91595	161	93039	32	94201	42
564138	176	90589	22	91603	162	93047	32	94235	54
564139	176	90597	163	91611	161	93054	32	94243	52
564235	172	90613	163	91629	162	93062	160	94250	54
564236	172	90639	163	91637	161	93070	160	94268	42
564237	172	90662	130	91645	162	93088	160	94276	54
564238	172	90670	122	91652	161	93096	160	94284	42
565859	146	90696	123	91660	162	93104	160	94292	42
565860	146	90712	128	91678	162	93112	74	94300	50
565861	146	90738	28	91686	162	93179	38	94318	50
565862	146	90746	28	91694	162	93195	76	94334	50
565863	129	90753	28	91702	162	93203	36	94359	48
565864	152	90761	28	91715	162	93211	36	94367	46
565865	152	90779	28	91793	162	93229	36	94391	52
565866	152	90787	135	91843	148	93237	36	94524	58
565898	164	90803	29	91868	148	93245	36	94540	58
565899	164	90811	29	91884	148	93252	36	94565	58
567170	148	90829	29	91900	153	93260	76	94623	58
569830	147	90837	29	91959	153	93328	38	94649	58
569831	147	90845	29	92007	153	93336	38	94664	58
569832	147	90878	26	92056	153	93427	40	94672	59
569833	147	90886	26	92072	153	93435	40	94680	59
569834	147	90894	26	92080	153	93443	40	94698	60
90001	12	90902	27	92098	153	93450	40	94706	60
90019	12	90910	27	92106	141	93484	155	94714	60
90027	12	90928	27	92114	153	93492	155	94755	62
90035	12	90944	31	92122	141	93500	155	94763	62
90043	12	90951	31	92130	153	93518	155	94771	62
90050	12	90969	31	92163	135	93526	155	94821	179
90068	12	90977	31	92361	161	93534	78	94839	179
90134	66	90985	31	92387	161	93542	38	94847	179
90142	66	90993	31	92403	159	93559	155	94854	179
90159	66	91009	31	92411	159	93567	155	94862	179
90167	118	91017	31	92429	159	93575	155	94870	179
90175	118	91025	31	92437	159	93583	155	95000	84
90183	118	91033	30	92445	161	93591	155	95026	84
90191	118	91041	30	92452	159	93609	144	95042	84
90209	68	91058	30	92460	161	93617	144	95067	84
90217	16	91066	30	92478	161	93625	144	95083	84
90225	16	91074	30	92486	159	93633	144	95091	95
90233	16	91082	30	92494	159	93641	144	95133	86
90241	16	91090	30	92502	159	93658	100	95141	88
90258	16	91108	30	92544	56	93666	81	95158	95
90266	16	91116	31	92569	56	93674	159	95166	88
90274	68	91124	31	92585	56	93682	159	95174	95
90282	68	91132	31	92601	56	93690	159	95182	88
90290	121	91173	31	92619	80	93708	159	95190	95
90308	121	91280	124	92627	57	93716	159	95208	88
90316	18	91314	26	92635	165	93831	44	95224	88
90324	18	91330	27	92643	57	93849	64	95265	92
90332	18	91348	125	92650	74	93856	64	95299	92
90340	18	91355	30	92668	57	93864	44	95349	94
90357	70	91363	30	92676	50	93880	44	95364	94
90365	70	91371	30	92684	57	93906	48	95380	94
90373	70	91389	30	92692	82	93914	48	95406	96
90381	121	91397	156	92809	158	93922	48	95422	96
90399	72	91405	156	92817	158	93930	48	95448	96

Order no.	Page	Order no.	Page	Order no.	Page	Order no.	Page	Order no.	Page
95455	97	96040	164	99002	164	99341	171	99556	168
95463	96	96057	164	99010	164	99358	171	99564	178
95489	96	96065	164	99028	164	99366	171	99572	178
95505	96	96073	164	99036	164	99374	171	99580	168
95521	98	96081	164	99044	164	99382	171	99598	168
95547	98	98012	166	99051	164	99390	168	99606	168
95562	98	98038	166	99069	164	99408	168	99614	165
95588	102	98046	166	99077	164	99416	168	99622	167
95596	97	98053	166	99085	164	99424	168	99630	165
95604	102	98061	166	99119	168	99432	168	99648	127
95620	102	98475	166	99127	168	99440	168	99655	165
95638	179	98517	167	99135	168	99457	168	99663	124
95646	179	98525	167	99143	168	99465	168	99671	165
95653	179	98533	167	99168	168	99473	168	99689	126
95661	179	98541	167	99259	170	99481	168	99705	167
95679	179	98558	167	99267	170	99499	168		
95687	179	98566	167	99275	170	99507	178		
96008	167	98582	167	99283	170	99515	178		
96016	167	98616	168	99309	171	99523	178		
96024	167	98632	168	99325	171	99531	178		
96032	167	98665	168	99333	171	99549	178		

... IN ALPHABETICAL ORDER

Description	Page
A	
Adapter	159
Adapter for perforated tables Ø 19 mm	176
Adapter plate, angular	174
Adapter plate, round	174
Angle base, solid	52, 95
B	
Base plate	31
Black handle, removable	43
Blue handle, removable	43
C	
Clamp arm	153, 162
Clamping arm	159
Clamping arm extension	31, 171
Clamping bolt for perforated tables	172
Clamping screw	164, 165, 166, 167, 168
Clamping screw, black	165, 167
Clamping screw holder	31
Combi-clamp, pneumatic	135
Combination clamp with black handle	45
Combination clamp with blue handle	45
Combination clamp with green handle	45
Combination clamp with orange handle	44
Combination clamp with red handle	44
Combination clamp with yellow handle	44
Counter catch	58, 59, 96, 97, 179
E	
ESD clamping screw	116
ESD horizontal toggle clamp	113
ESD push-pull type toggle clamp	114, 115
ESD vertical toggle clamp	112
G	
Green handle, removable	43
Grooved nut (DIN 70852)	160
H	
Hand grip	30
Heavy hook type toggle clamp	64
Heavy pneumatic toggle clamp	140, 141, 142, 152
Heavy push-pull type toggle clamp	56, 57
Heavy vertical toggle clamp	26, 27
Heavy-duty push-pull type toggle clamp with black handle	55
Heavy-duty push-pull type toggle clamp with blue handle	54
Heavy-duty push-pull type toggle clamp with green handle	55
Heavy-duty push-pull type toggle clamp with orange handle	54
Heavy-duty push-pull type toggle clamp with red handle	54

Description	Page
Heavy-duty push-pull type toggle clamp with yellow handle	54
Hook type toggle clamp	58, 59, 96, 97
Hook type toggle clamp with safety latch	81
Horizontal acting toggle clamp	42
Horizontal hook-type toggle clamp with black handle	61, 99
Horizontal hook-type toggle clamp with black handle and safety latch	83, 101
Horizontal hook-type toggle clamp with blue handle	60, 98
Horizontal hook-type toggle clamp with blue handle and safety latch	82, 100
Horizontal hook-type toggle clamp with green handle	61, 99
Horizontal hook-type toggle clamp with green handle and safety latch	83, 101
Horizontal hook-type toggle clamp with orange handle	60, 98
Horizontal hook-type toggle clamp with orange handle and safety latch	82, 100
Horizontal hook-type toggle clamp with red handle	60, 98
Horizontal hook-type toggle clamp with red handle and safety latch	82, 100
Horizontal hook-type toggle clamp with yellow handle	60, 98
Horizontal hook-type toggle clamp with yellow handle and safety latch	82, 100
Horizontal toggle clamp, black	120, 121, 122, 123
Horizontal toggle clamp plus with black handle	35, 91
Horizontal toggle clamp plus with blue handle	34, 90
Horizontal toggle clamp plus with green handle	35, 91
Horizontal toggle clamp plus with orange handle	34, 90
Horizontal toggle clamp plus with red handle	34, 90
Horizontal toggle clamp plus with yellow handle	34, 90
Horizontal toggle clamp with auto-adjust clamping height	106, 107, 108
Horizontal toggle clamp with black handle	33, 37, 39, 41, 89
Horizontal toggle clamp with black handle and safety latch	75, 77, 79
Horizontal toggle clamp with blue handle	32, 36, 38, 40, 88
Horizontal toggle clamp with blue handle and safety latch	74, 76, 78
Horizontal toggle clamp with green handle	33, 37, 39, 41, 89
Horizontal toggle clamp with green handle and safety latch	75, 77, 79
Horizontal toggle clamp with open-holder, black	129
Horizontal toggle clamp with orange handle	32, 36, 38, 40, 88
Horizontal toggle clamp with orange handle and safety latch	74, 76, 78
Horizontal toggle clamp with red handle	32, 36, 38, 40, 88
Horizontal toggle clamp with red handle and safety latch	74, 76, 78
Horizontal toggle clamp with safety latch, black	127, 128, 130
Horizontal toggle clamp with yellow handle	32, 36, 38, 40, 88
Horizontal toggle clamp with yellow handle and safety latch	74, 76, 78

These Terms of Payment apply for companies, legal entities governed by public law and public law special funds. Our goods and services are supplied exclusively on the basis of the following conditions. Any deviating purchasing conditions of the customer not expressly recognised by us will not become part of the contract through acceptance of the order. By placing the order and accepting the goods we deliver, the customer confirms its consent to our terms and conditions.

1. Offer and contractual conclusion

All our offers are always subject to change without notice unless otherwise explicitly agreed. Our delivery contracts are based on the latest version of our catalogue. Dimension and weight values, as well as illustrations, drawings and data, are non-binding and can be changed by us at any time. Therefore, deviations cannot be ruled out and do not justify any compensation claims against us.

Orders are considered accepted only when confirmed by us in writing. If, for organisational reasons, the customer does not receive a separate confirmation upon the delivery of goods, the invoice shall also be deemed the order confirmation.

2. Prices

The prices are in EURO, ex-works, excluding VAT, packing, freight, postage and insurance. Unless otherwise agreed, our list prices valid on the day of delivery shall apply. For orders below 50 EUR goods net, we must make a minimum quantity surcharge of a 20 EURO for cost reasons.

3. Tool costs

Unless any other agreements have been reached, the tools fabricated for the purpose of executing the order shall remain our property in all cases, even if we have invoiced a tool cost component separately.

4. Payment

Unless otherwise stated on the invoice, the purchase price falls due for net payment within 30 days of the invoice date (without deduction of discount). Invoice amounts of below 50 EURO are due for payment immediately.

In case of payment default, we shall be entitled to charge default interest. The amount corresponds to our interest rate for current account credits at our main bank; the minimum however being 8 percentage points above the relevant base interest rate applied by the European Central Bank. Moreover, in case of default following written notice to the customer, we shall be entitled to cease to fulfil our obligations until payments are received.

5. No set-off

The customer can set-off only with legally confirmed or undisputed counterclaims.

6. Right of withdrawal in case of delayed acceptance or payment and insolvency

If the customer fails to accept the goods in due time, we shall be entitled to set a reasonable period of grace, after which we can dispose of the goods elsewhere and supply the customer on a reasonably longer term. Our rights to withdraw from the contract under the provisions of Section 326 BGB and demand damages for non-performance shall not be affected. If the customer fails to pay for the goods once payment is due, we shall be entitled, at the end of a reasonable period of grace we have set, to withdraw from the contract and demand the return of any goods already supplied. Section 323 BGB remains unaffected in all other cases.

If the customer applies for the opening of insolvency proceedings, we shall be entitled, prior to the ordering of security measures by the insolvency court, to withdraw from the contract and demand the immediate return of the goods.

7. Customer-specific fabrications/project fabrications (custom fabrications)

Customer-specific fabrications require binding information on design, quantity etc. in written form at the time of ordering. For manufacturing reasons, we reserve the right to supply up to 10% above or below the order quantity. Technical modifications or cancellations are subject to any costs incurred. The return of customer-specific fabrications is impossible.

8. Delivery and packaging, transfer of risk

The delivery date is non-binding; although stated to the best of our knowledge. It is subject to us receiving correct, defect-free and complete deliveries. The stated delivery dates relate to completion in the factory, starting on the day the order is accepted by us. Delivery is EXW (ex-works) in accordance with Incoterms 2020. Therefore, the costs are borne by the customer. The risk is transferred to the customer when the goods are passed to the person, company or facility nominated to execute the shipment. This applies also for partial deliveries, or if we have assumed responsibility for delivery and installation. The risk shall be transferred to the customer even in the case of delayed acceptance.

In the absence of specific shipping instructions, we shall proceed as we deem fit and without any obligation to the cheapest or most expedient method. The customer agrees that the order can also be delivered in parts, insofar as this is reasonable for the customer. We shall charge a 10 EURO processing fee for shipping to third parties that we supply on behalf of the customer.

The packaging complies with the packaging ordinance. Disposable packaging shall be charged at cost price. The packaging cannot be taken back.

9. Performance impediment and/or impossibility

If we are hindered in the fulfilment of our obligation due to the onset of unforeseeable circumstances, which we are unable to avoid despite reasonable effort in relation to the nature of the circumstances (e.g. operational interruption, delay in the delivery of important raw materials, defects in the delivery), the delivery time shall be extended by a reasonable period, insofar as the supply of goods or services is not rendered unreasonably difficult or impossible.

If we have to accept that these circumstances are not only temporary, we shall be entitled to withdraw from the contract either in whole or in part.

If the supply of goods or services becomes impossible, the customer shall not be obliged to furnish its own contractual service. Section 275 BGB applies mutatis mutandis. If, however, the customer is solely or predominantly responsible for the

circumstances that led to impossibility, it shall remain under an obligation to render the return service. The same applies if this circumstance occurs at a time when the customer is behind schedule with acceptance.

10. Samples/returns

Samples shall be provided only against payment. If samples or models are provided, a credit note shall be issued with the subsequent order if the order value is 125 EURO net or more. Goods can be returned only by agreement, although custom fabrications are excluded from such return.

In the case of returns for which we are not responsible (e.g. incorrect order), we shall charge a processing fee of 10%, the minimum value, however, being 7.50 EURO.

11. Retention of title

The goods shall remain our property unless full payment of all claims and/or until the cheques provided for this purpose are honoured. The itemisation of claims in an ongoing invoice, as well as balancing the account and the recognition thereof does not affect the retention of title. The customer is entitled to sell on the retained goods during the ordinary course of business. However, the customer is not permitted to pledge the goods or transfer them by way of security. It shall assign its claim ensuing from the selling on of the retained goods to us in advance. The customer shall be entitled to collect the claim to the extent that it has fulfilled its obligations towards us. At our request, the customer shall be obliged to state third-party debtors and we shall be entitled to report this and the assignment.

12. Property rights

We reserve property rights and copyrights to all contractual documents such as drafts, drawings, calculations and cost estimates. Such documents must not be reproduced or disclosed to third parties without our consent. Any rights to patents, utility models etc. reside solely with us, insofar as such patents have not yet been filed. Our products are allowed to be replicated only with our written consent.

If objects are fabricated according to drawings or samples, the customer shall warrant that any third party property rights are not infringed by manufacture or delivery. If a third party forbids manufacture and delivery on account of property rights, we shall be entitled to stop manufacture and delivery immediately. The customer shall be obliged to reimburse us with all costs incurred and indemnify us from third party compensation claims. Compensation claims by the customer are impossible.

13. Warranty

If the customer agrees with us a particular quality of the goods, we shall base this agreement on our technical delivery specifications. If we have to deliver according to customer drawings, specifications, samples etc., the customer shall assume the risk for suitability for the intended purpose. If, after the contract is concluded, the scope of goods or services is changed at the customer's request and this impairs the quality or suitability of the goods, claims for defects on the part of the customer shall be ruled out, insofar as such impairments are caused by the customer's requests for change.

The time at which the risk is transferred is decisive for the contractual state of the goods. Wear and tear of wearing parts caused by ordinary use does not constitute a defect. Claims for defects are ruled out in the following cases in particular: Unsuitable or improper use, incorrect installation and/or commissioning by the customer or third party, normal wear and tear, incorrect or negligent handling - in particular excessive use -, unsuitable equipment, replacement materials, chemical, electrochemical or electrical influences, unless such defects are caused by ourselves.

If the goods contain a defects, we shall provide, following a reasonable period of grace set by the customer, either a replacement or a repair as we deem fit. If such subsequent performance fails, the customer shall be entitled to either reduce the purchase price or withdraw from the contract. Any further warranty claims are ruled out. In case of negligible deviations from the agreed quality, no claims for defects shall be recognised.

The discovery of defects must be communicated to us immediately in writing. In the case of recognisable defects, however, within 10 days of acceptance, in the case of non-recognisable defects immediately after they become evident. The warranty is 12 months, starting with delivery of the goods ex-works.

14. Liability

With the exception of harm to life, body or health on account of a breach of duty by ourselves, our liability shall be limited to intent or gross negligence.

15. Place of fulfilment, place of jurisdiction and governing law

The place of fulfilment for all obligations ensuing from this contractual relationship is D-70734 Fellbach.

The place of jurisdiction for all legal disputes ensuing from the contractual relationship is the court responsible for the headquarters of Andreas Maier GmbH & Co. KG.

All disputes ensuing from the contract or regarding the validity thereof shall be finally decided by a court of arbitration in accordance with the Court of Arbitration Ordinance of the German Committee for Arbitration Court Procedures or the Conciliation and Arbitration Arrangement of the International Chamber of Commerce, recourse to ordinary courts of law being excluded. The legal dunning process, however, remains permissible.

German law shall govern (BGB and HGB). The applicability of the UN Convention on Contracts for the International Sale of Goods (CISG) is ruled out.

16. Severability clause

If individual provisions become legally invalid, the remaining provisions shall not be affected. The legally invalid provision shall be replaced by regulations that most closely reflect the economic purpose of the contract with reasonable consideration for the mutual interests. The publication of these Terms of Sale, Delivery and Payment renders all previous versions invalid. This does not apply for any contracts concluded prior to announcement.

TOGGLE CLAMPS, MANUAL AND PNEUMATIC CATALOGUE 2026

Request additional catalogues from www.amf.de



ZERO-POINT-SYSTEMS



HYDRAULIC CLAMPING SYSTEMS



MAGNETIC CLAMPING SYSTEMS



WIRELESS SENSING SYSTEMS



TOGGLE CLAMPS



SINGLE AND MULTIPLE CLAMPING SYSTEMS



STANDARD CLAMPING SYSTEMS



MARKING AND CLEANING TOOLS



ANDREAS MAIER GmbH & Co. KG

Waiblinger Straße 116 · D-70734 Fellbach

Phone: +49 711 5766-0

Fax: +49 711 575725

E-mail: amf@amf.de

Web: www.amf.de

Order no. 462978 · € 3,60