



Metal Bellows Coupling I Series KHS

- /// High-speed version for highest operating speeds
- /// rotationally symmetrical construction - optimum balance quality
- /// conical clamping ring hubs on both sides / 4-bladed metal bellows
- /// corrosion-resistant material version

technical data:

KHS	nominal torque	moment of inertia	torsional stiffness (stat. $0,5 \times T_N$)	max. shaft displacement (mm)		axial spring rate	lateral spring rate	mass approx.	maximum rotational speed
Size	[Nm]	[10^{-3}kgm^2]	[Nm/arcmin]	axial \pm lateral		[N/mm]	[N/mm]	[kg]	[Upm]
25	25	0,04	3,4	0,5	0,1	55	360	0.25	57000
50	50	0,18	9	0,6	0,1	70	450	0,5	40000
80	80	0,5	26	0,6	0,1	70	600	1,0	35000
220	220	1,1	37	0,6	0,1	150	1600	1,5	28000
450	450	3,0	70	0,7	0,1	135	1500	3,0	23000
700	700	7,0	100	0,7	0,1	145	3000	4,5	19000

temperature range: -40°C up to $+200^\circ\text{C}$

material:

bellows: stainless steel 1.4571

conical hub: stainless steel 1.4301

conical ring: high-tensile aluminum

screws: ISO 4762

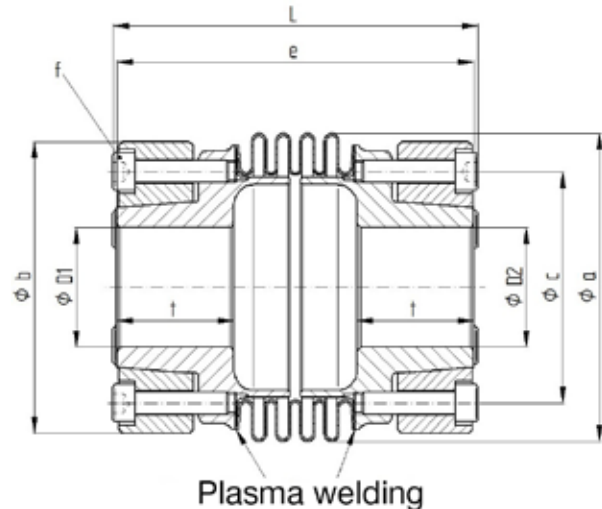

Dimensions [mm]: length dimensions according to DIN ISO 2768 cH

KHS	$\varnothing a$	$\varnothing b$	$\varnothing c$	$L \pm 1$	$e \pm 1$	f-max. torque	$t1 / t2$	$\varnothing D1/2$ min	$\varnothing D1/2$ max
size									
25	40	38	27	67	63	6x M4 - 3Nm	22	5	15
50	56	53	40	74	72	6x M4 - 4Nm	23	9	22
80	66	66	52	81	80	6x M5 - 8Nm	27,5	11	32
220	82,5	78	62	98	95	6x M6 - 14Nm	31,5	14	40
450	101	98	78	113	109	6x M8 - 30Nm	38	15	48
700	122	113	91	132	129	6x M10 - 50Nm	45	19	60

note: Optionally balanced with balancing quality „Q1“. Larger sizes on request.

order example: KHS 80 - D1 = 16 ^{G7} D2 = 24 ^{H7}