

Safety coupling I Series SKW - EK for direct drives

- /// with elastomer attachment for direct drives // easy keyway connection
- /// elastomer coupling with radial clamping hub // plug in, backlash free, flexible, robust, oscilation dampening

Technical data:

SKW - EK size	setting range disengagement torque T_{KA} [Nm]	moment of inertia $[10^{-3} \text{kgm}^2]$	mass approx. [kg]	torsional stiffness [Nm/arcmin]	max. shaft displacement [mm]		tightening torque of screws „f“ [Nm] *	$\varnothing D1$		$\varnothing D2$	
					axial \pm	lateral		min	max	min	max
6	2 - 6	0,11	0,4	0,25	0,5	0,1	M5 - 8	8	20	6	12
12	6 - 12							8	20	6	12
15	8 - 15	0,44	0,9	1,0	0,5	0,1	M6 - 14	12	32	8	22
30	13 - 30							12	32	10	22
45	22 - 45							14	32	10	22
60	25 - 60	1,35	1,7	1,2	1	0,1	M8 - 35	16	38	11	32
100	40 - 100							19	38	13	32
150	60 - 150							22	38	16	32
230	80 - 230	5,1	3,9	3,6	1	0,12	*M12 - 115 (90)	20	35(43)	18	38
330	130 - 330							24	35(43)	21	38
500	200 - 500	14,4	7,0	8,0	1	0,15	*M14 - 180 (140)	30	60(70)	26	55
800	350 - 800							40	60(70)	38	55
1000	500 - 1000	54	15,1	12	1	0,1	*M14 - 180 (140)	42	60(70)	39	90
2000	800 - 2000	91	23,3	21	1	0,15	M16 - 290	50	90	39	90

(*) note: reduced tightening torque for bigger hub bore diameter - see also $\varnothing D1$ max!

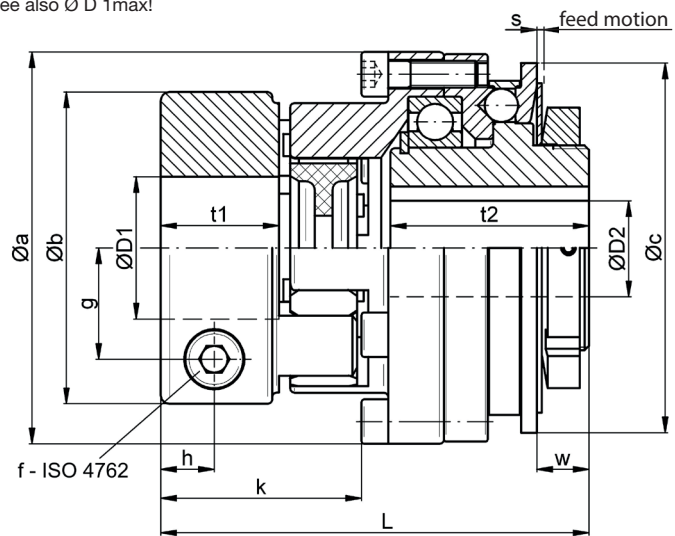

Material:
 safety part: heat treated steel
 clamping hub: high tensile aluminium
 (size 2000: tempered steel)
 elastomer spider: polyurethane - 98 Shore-A
 temperature range: -30°C up to +90°C

Dimensions [mm]: length dimensions according to DIN ISO 2768 cH

SKW - EK	$\varnothing a$	$\varnothing b$	$\varnothing c$	g	h	k	L ± 1	s	t1	t2	w
6/12	52,5	40	48	13	8	33	67	0,9	17	31	5,8
15/30/45	69	55	66	20	10	39	81,5	1,2	21	38	8,6
60/100/150	88	70	83	25	12	45	96	1,6	26,5	44,5	11,4
230/330	115	85	109	29	14	54	121	1,8	31	59,5	13,7
500/800	137	120	132	44	18	71	148,5	2,5	38	68,5	18,1
1000	181	120	185	44	18	72	170,5	3,7	38	90	40,4
2000	181	160	185	55,5	21	84	182,5	3,7	42	90	40,4

- notice:
- /// other shore-hardnesses of elastomer spider are possible on request
 - /// shaft bore of clamping hub „D1“ optionally with additional keyway
 - /// axial fixing of safety part optionally by additional snap ring

Ordering example: SKW - EK 60 - D1 = $\varnothing 32^{G7}$ - D2 = $\varnothing 24^{H7}$ - keyway 8P9 x 3,3 - $T_{KA} = 55 \text{ Nm}$