

# Spring Clamping Cylinder I Series ZSF

## Technical data:

ZSF Size	nominal clamping force [kN]	adjusting pressure [bar]	max release stroke [mm]	release pressure at 0,5 mm stroke [bar]	release pressure at 1,0 mm stroke [bar]	release pressure at max stroke [bar]	stroke volume at 1 mm stroke [cm <sup>3</sup> ]	mass approx. [kg]
1.600	16	135	2,0	170	210	290	1,3	2,0
2.500	25	135	1,6	160	185	230	2,0	3,0
4.000	40	150	2,0	170	190	240	2,8	4,5
6.300	63	175	1,5	190	210	235	3,8	6,8
10.000	100	210	1,5	250	280	320	5,0	8,5
16.000	160	210	1,2	240	275	295	7,9	21
20.000	200	210	1,2	240	270	290	11,3	26,5
25.000	250	190	1,6	210	235	260	14,3	41
35.000	350	190	1,0	210	230	230	20,1	60

temperature range: -30°C up to +100°C – mounting position: discretionary



update version

material:  
heat-treated steel, burnished

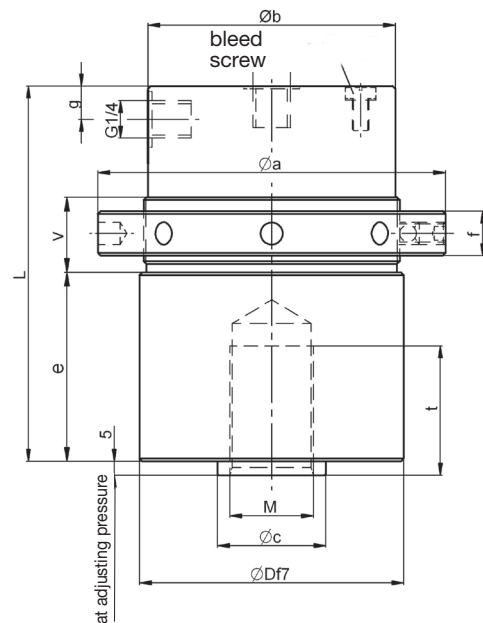
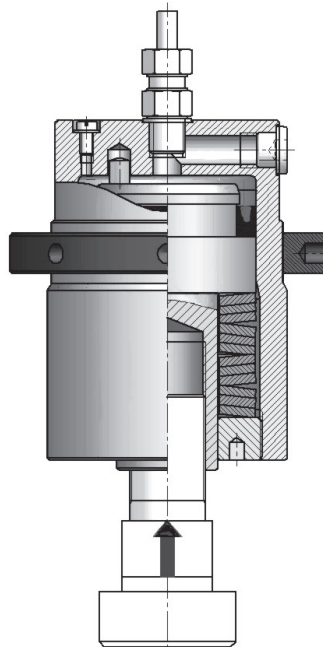

Dimensions [mm]: length dimensions according to DIN ISO 2768 mH

ZSF Size	Ø D f7	"Version-2" Ø D f7	Ø a	Ø b	Ø c	e	f	g	L	M*	t	v	adjustment thread - ring nut
1.600	60	55	85	55	20	40	14	12	101	M 14 x 1,5	24	22	M 58 x 1,5
2.500	70	65	95	65	25	46	14	13	111	M 18 x 1,5	30	23	M 68 x 1,5
4.000	80	75	110	75	30	56	16	12	125	M 22 x 1,5	36	24	M 78 x 1,5
6.300	95	85	125	89	40	67	16	12	135	M 30 x 1,5	48	28	M 92 x 1,5
10.000	105	95	140	100	40	78	16	18,5	150	M 30 x 1,5	50	35	M 102 x 1,5
16.000	142	130	180	137	50	75	32	22	170	M 38 x 1,5	50	50	M 140 x 2
20.000	150	-	190	143	57	92	40	22	200	M 45 x 1,5	60	58	M 148 x 3
25.000	170	-	220	163	70	100	40	22	230	M 45 x 1,5	60	58	M 168 x 3
35.000	200	-	250	192	80	100	45	47	240	M 52 x 1,5	70	65	M 198 x 3

**Note Version-2:** Sizes 1.600 to 10.000 are available alternatively with smaller external diameter "D" cylinder housing according to column "-2". Other thread sizes or through holes available on request.

\*Alternative threaded version available on request

Ordering example: ZSF 25.000 / ZSF 6.300 - 2