

Icarus

Mist Collector



Icarus

Icarus is a static exhaust fan for filtration of air containing oil mists, micro-mists and smokes, generated from coolants (both emulsion or neat oil), which can be used on every kind of machine tool and for every removal machinery.

Icarus is available in three sizes with flowrate from 600 to 2.000 m³/h with different filtration efficiency combination, up to performances of 99,97%.



LOSMA grants that every single system is tested through strict control procedures.

Every unit is provided with a qualitative and functional test certificate.



Icarus M



Icarus S



Icarus L

Working principles

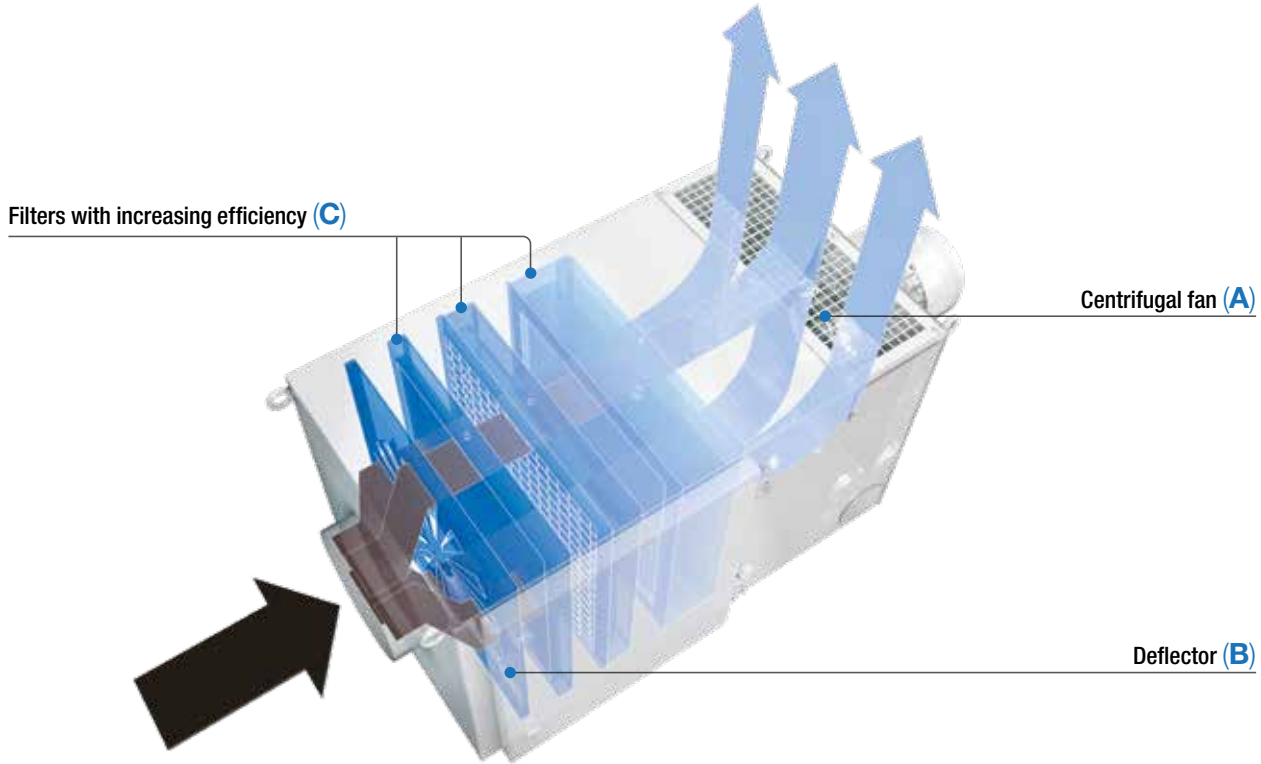

1 Polluted air is drawn in by a high efficiency centrifugal fan (A), mounted behind the filters. In this way the fan cannot be damaged, since it works with clean air without any pollutant residual.

2 Air passes initially through a special deflector (B), whose function is to distribute uniformly the air onto filter's surface, assuring a proper

use of the whole useful contact area of the filter.

3 Then the air crosses a series of filters with increasing efficiency (C) up to more than 95% with polluted particles measuring less than a micron. Efficiency can reach 99,97% with the use of a HEPA post-filter following EN 1822 regulation.

Filter series - Standard equipment

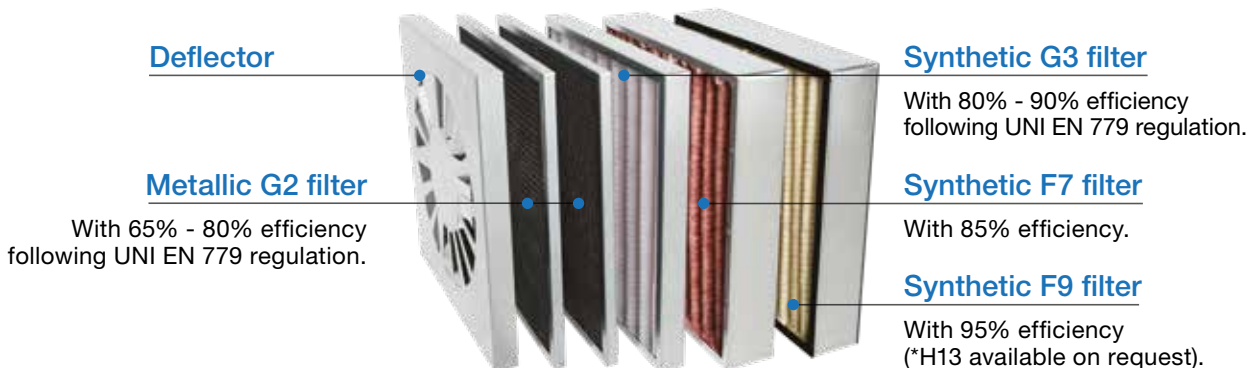

Plus



VERSATILITY AND MODULARITY

The use of filters with increasing efficiency and the possibility of implementing pre and post-filtration systems make Icarus the ideal filter for all modern mechanical machining, from the simplest to the most demanding ones. The three different sizes of Icarus facilitate the choice for the most appropriate solution for the customer's needs, avoiding energy waste for oversized systems, or insufficient performance from undersized systems.



MANOMETER

Icarus is equipped with a precise tool to read the internal filter obstruction state.



ENERGY EFFICIENCY

Using centrifugal fans with high efficiency grants high performances for flowrate and pressure, together with reduced power consumption and limited energy usage. Icarus also has very low noise emission.



GREEN

Losma has always paid many attentions to eco-sustainability of its products and to the eco-friendly life of its spare parts. That's why an eco-compatible patented BIO FILTER was developed, made only of natural fibres it can be used as pre-filter replacing the synthetic filters.



EASY AND QUICK MAINTENANCE

Access to filtering section is very easy and quick, you don't need to unscrew or dismantle any part. Just open the two locks on the door and access to the filters, which can be extracted easily and changed in a few minutes.

Technical data

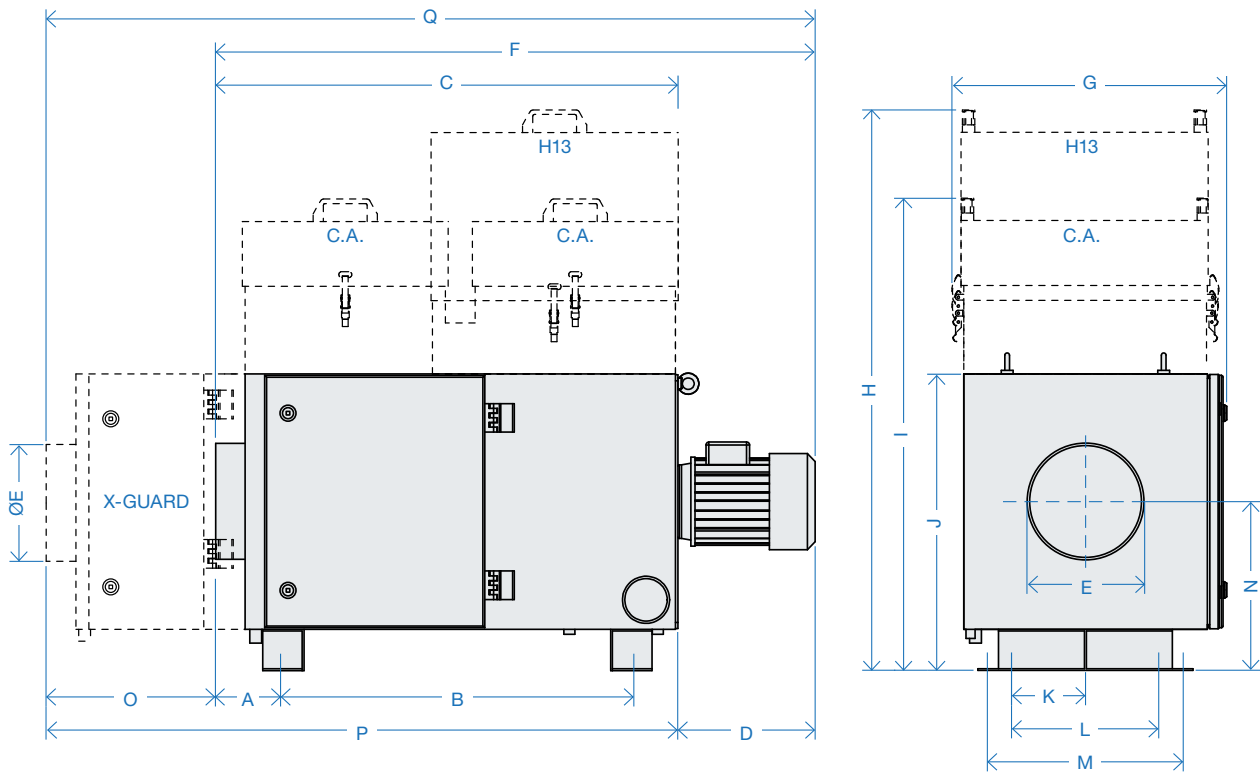

MODELS	Dimensions (mm)																
	A	B	C	D	E	F	G	H	I	J	K	L	M	N	O	P	Q
Icarus S	110	500	660	210	148	870	450	930	785	505	125	250	365	290	287	897	1107
Icarus M	110	600	785	235	198	1020	450	930	785	505	125	250	365	290	287	997	1232
Icarus L	170	600	815	270	198	1095	570	1050	905	625	125	250	365	350	287	1047	1317

MODELS	Power (kW)	Max air flow (m ³ /h)		Head	Noise level	Inlet	RPM (rpm)		Net Weight (Kg)
	50 (Hz) / 60 (Hz)	50 (Hz)	60 (Hz)	(mm H ₂ O)	(dba)	(mm)	50 (Hz)	60 (Hz)	
Icarus S	0,37 / 0,44	600	665	52	68,1	150	2820	3360	52
Icarus M	0,75 / 0,75	1040	1150	103	69,9	200	2900	3390	57
Icarus L	1,5 / 1,5	1680	1890	91	73,8	200	2880	3410	81

Icarus-E

Icarus-E is an electrostatic filter for filtration of air containing oil mists, micro - mists, vapours and smokes generated by removal machining, especially those using neat oil.

It's available in three sizes from 600 to 1.700 m³/h with different increasing filtering efficiency combinations, up to 99,97% (with the use of HEPA H13 final filter).

Standard equipment of the system is made by an electrical control box, "CE" regulation compliant, including an obstruction alarm, power alarm and micro-switch for safety.



LOSMA grants that every single system is tested through strict control procedures.

Every unit is provided with a qualitative and functional test certificate.



Icarus-E M



Icarus-E S



Icarus-E L

Working principles

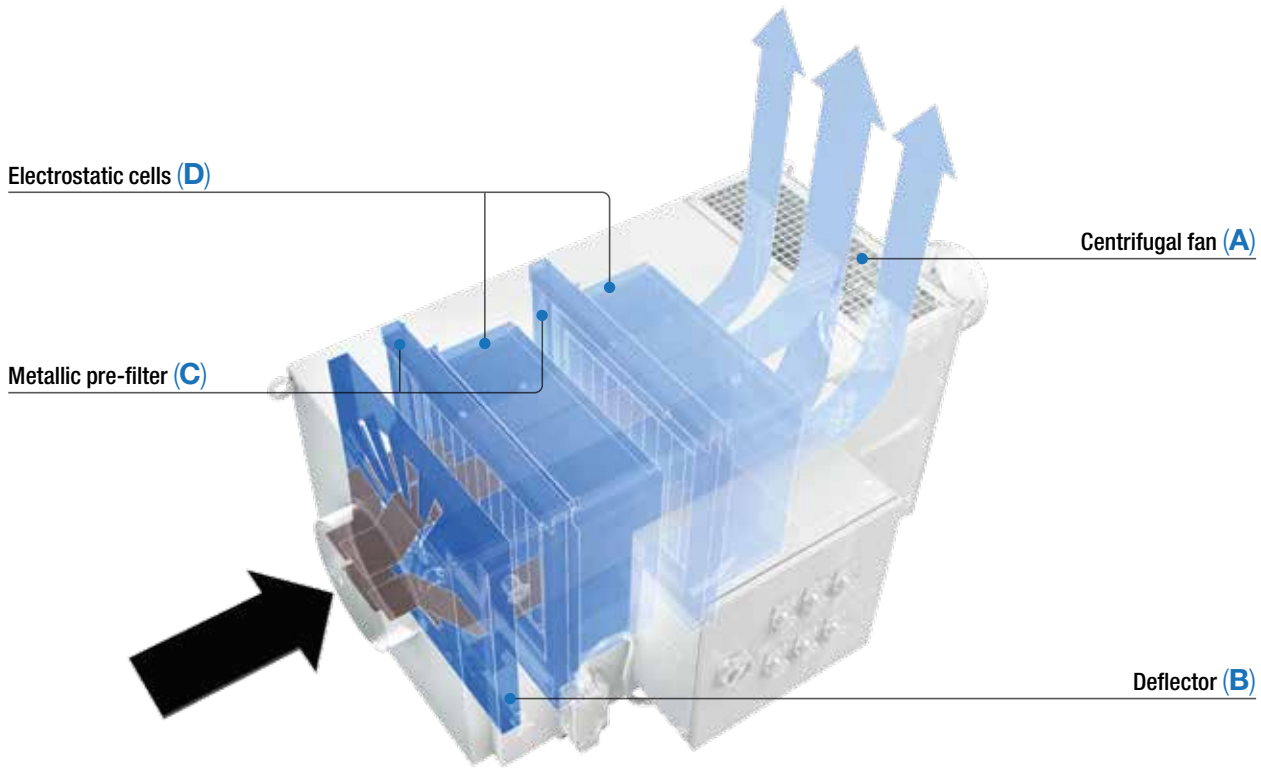

- 1** Polluted air is drawn in by a high efficiency centrifugal fan (A), mounted behind the filters. In this way the fan cannot be damaged, since it works with clean air without any pollutant residual.
- 2** Air passes initially through a special deflector (B), whose function is to distribute uniformly

- the air onto filter's and cell's surface.
- 3** After passing through the metallic pre-filter (restorable) (C) air passes through the ionizing section of cells (D), charging electrostatically, and passing then into the collector section composed by many aluminium foils, which holds firmly also the finest particles.

Filter series Standard equipment Icarus-E S

Synthetic F7 filter
With 85% efficiency.

Electrostatic washable cell

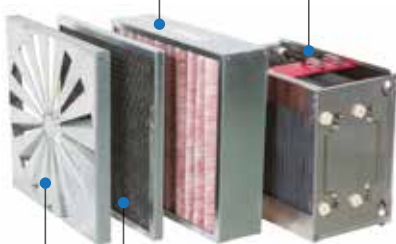

Deflector

G2 metallic filter (washable)
With an efficiency range of 65-80% following the regulation UNI EN 779

Filter series Standard equipment Icarus-E M+L

Electrostatic washable cell



Deflector

G2 metallic filter (washable)
With an efficiency range of 65-80% following the regulation UNI EN 779

Plus



VERSATILITY AND MODULARITY

The use of filters with increasing efficiency and the possibility of implementing pre and post-filtration systems makes Icarus-E the ideal filter for all modern mechanical machining, from the easiest to the most demanding ones. The three different building versions and the different sucking power of Icarus-E facilitate the choice for the best appropriate solution for customer needs, avoiding energy waste for over dimensioned systems, or inefficient systems for low power selection.



RESTORABLE*

Icarus-E uses only restorable filters, allowing savings for buying, maintenance and disposal of the regular obstruction filters.

* Icarus-E S version pre-filtration is made with an F7 filter.



ENERGY EFFICIENCY

Using centrifugal fans with high efficiency grants high performances for flowrate and pressure, even with reduced power installation and limited energy usage. Icarus-E is also very silent.

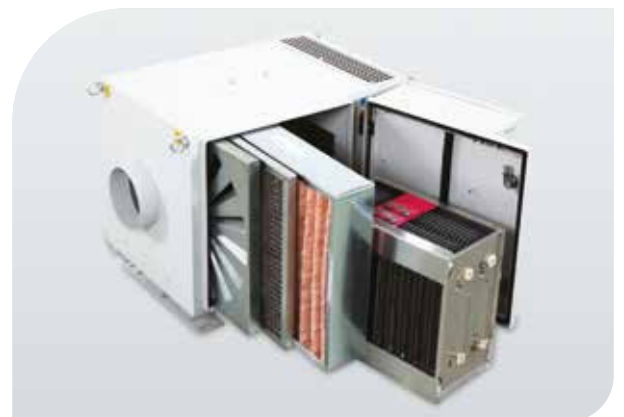

EASY AND QUICK MAINTENANCE

Access to filtering section is very easy and quick, you don't need to unscrew or dismantle any part. Just open the two locks on the door and access to the filters, which can be extracted easily and changed in a few minutes.

Technical data

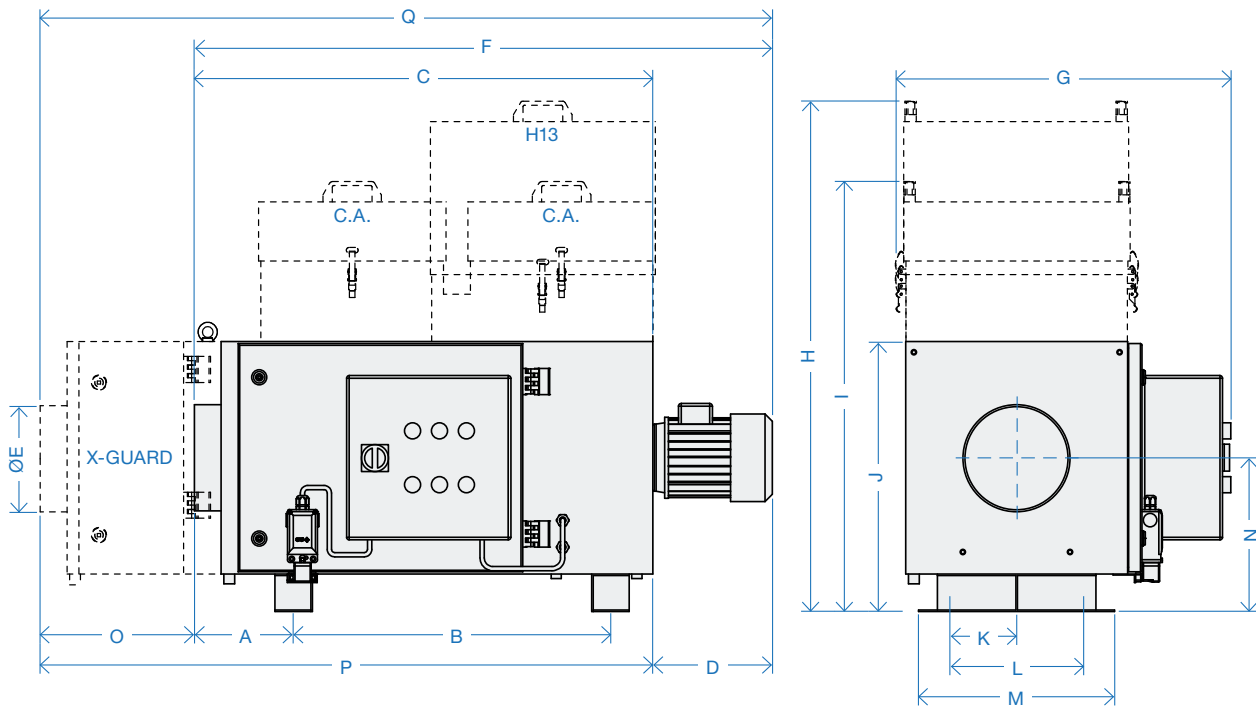

MODELS	Dimensions (mm)																
	A	B	C	D	E	F	G	H	I	J	K	L	M	N	O	P	Q
Icarus ES	130	500	655	210	148	865	450	930	785	505	125	250	365	290	287	942	1152
Icarus EM	180	600	855	235	198	1105	450	930	785	505	125	250	365	290	287	1157	1392
Icarus EL	160	600	855	270	198	1215	570	1050	905	625	125	250	365	350	287	1172	1442

MODELS	Power (kW)	Max air flow (m ³ /h)		Head	Noise level	Inlet	RPM (rpm)		Net Weight (Kg)
	50 (Hz) / 60 (Hz)	50 (Hz)	60 (Hz)	(mm H ₂ O)	(dba)	(mm)	50 (Hz)	60 (Hz)	
Icarus ES	0,37 / 0,44	600	665	80	68,1	150	2820	3360	52
Icarus EM	0,75 / 0,75	1040	1150	125	69,9	200	2900	3390	57
Icarus EL	1,5 / 1,5	1680	1890	130	73,8	200	2880	3410	81

Optional

High efficiency H13 filter

Provides a very high filtration efficiency, up to 99,97%, following the EN 1822 regulation. Useful in case of micro-mists and smokes.



X Guard

Pre-filtration module for swarf and dust, working through metallic and synthetic filtration stages. Useful to optimize the air suction efficiency in case of high production of oil mists containing dusts and metallic swarf.

C.A. After filter

Activated carbons after filter reduce smoke, gas particles, unpleasant and/or noxious odours generated by some machining processes.

Installations



Icarus



Icarus-E





Health



Savings



Efficiency



Environment



Safety



Losma SpA

HQ:

Via E. Fermi, 16 - 24035 Curno - Bergamo
Tel. +39 035 461444
info@losma.it - www.losma.it



ISO 9001
TUV Italia
Certified
Company



ISO 14001
TUV Italia
Certified
Company



Authorised
to use

Losma SpA

Turin office:

Via G. Brunero, 2 - 10077 San Maurizio Canavese - Torino
Tel. +39 011 9278942
info@losma.it - www.losma.it

Losma GmbH

Siemensstr. 14/3 - 71691 Freiberg am Neckar
Tel. +49 7141 / 89971-10
info@losma.de - www.losma.de

Losma Inc.

30A Wilson Drive - Sparta - NJ 07871
Tel. +1 973 300 1044
sales@losmausa.com - www.losma.com

Losma UK Ltd.

6 Strensham Business Park
WR8 9JZ Strensham Worcestershire
Tel. +44 1684 276527
info@losma.co.uk - www.losma.co.uk

Losma Pvt Ltd.

Plot No 7A, Gat. No. 63, Shindewadi
Tal: Bhor, District: Pune - 412205 - Maharashtra
Tel. +91 92261 07775
info@losma.in - www.losma.com