

## No. 6800

### Vertical toggle clamp with red handle

#### with open clamping arm and horizontal base.

Galvanized and passivated. Rivets made of stainless steel, which, for sizes 2 to 6, run in hardened bushings. Bearings are pre-lubricated.

Ergonomic, oil-resistant handle with large grip surface and soft components. Safety clamping piece with finger protection, lock washer for the thrust bolt at the end of the clamping arm.

**Complete with tempered, galvanized clamping screw no. 6890.**



Order no.	Size	F1 [kN]	F2 [kN]	Clamping screw	Weight [g]
90001	0	0,5	0,7	M 4x 25	60
90019	1	0,6	1,1	M 5x 30	105
90027	2	0,8	1,2	M 6x 35	175
90035	3	1,2	2,5	M 8x 45	410
90043	4	1,7	3,0	M 8x 65	630
90050	5	3,0	5,0	M12x 80	1480
90068	6	3,4	5,5	M12x110	2200

Also available in „STAINLESS STEEL“ version (no. 6800NI) and in matte-black version (no. 6800B)!

## No. 6800Y

### Vertical toggle clamp with yellow handle



Order no.	Size	F1 [kN]	F2 [kN]	Clamping screw	Weight [g]
557009	0	0,5	0,7	M 4x 25	60
557010	1	0,6	1,1	M 5x 30	105
557011	2	0,8	1,2	M 6x 35	175
557012	3	1,2	2,5	M 8x 45	410
557013	4	1,7	3,0	M 8x 65	630
557014	5	3,0	5,0	M12x 80	1480
557015	6	3,4	5,5	M12x110	2200

Also available in „STAINLESS STEEL“ version (no. 6800NIY).

## No. 6800J

### Vertical toggle clamp with orange handle



Order no.	Size	F1 [kN]	F2 [kN]	Clamping screw	Weight [g]
557301	0	0,5	0,7	M 4x 25	60
557302	1	0,6	1,1	M 5x 30	105
557303	2	0,8	1,2	M 6x 35	175
557304	3	1,2	2,5	M 8x 45	410
557305	4	1,7	3,0	M 8x 65	630
557306	5	3,0	5,0	M12x 80	1480
557307	6	3,4	5,5	M12x110	2200

Also available in „STAINLESS STEEL“ version (no. 6800NIJ).

## No. 6800E

### Vertical toggle clamp with blue handle



Order no.	Size	F1 [kN]	F2 [kN]	Clamping screw	Weight [g]
557615	0	0,5	0,7	M 4x 25	60
557616	1	0,6	1,1	M 5x 30	105
557617	2	0,8	1,2	M 6x 35	175
557618	3	1,2	2,5	M 8x 45	410
557619	4	1,7	3,0	M 8x 65	630
557620	5	3,0	5,0	M12x 80	1480
557621	6	3,4	5,5	M12x110	2200

Also available in „STAINLESS STEEL“ version (no. 6800NIE).

Subject to technical alterations.

## No. 6800G

### Vertical toggle clamp with green handle



Order no.	Size	F1 [kN]	F2 [kN]	Clamping screw	Weight [g]
557465	0	0,5	0,7	M 4x 25	60
557466	1	0,6	1,1	M 5x 30	105
557467	2	0,8	1,2	M 6x 35	175
557468	3	1,2	2,5	M 8x 45	410
557469	4	1,7	3,0	M 8x 65	630
557470	5	3,0	5,0	M12x 80	1480
557471	6	3,4	5,5	M12x110	2200

Also available in „STAINLESS STEEL“ version (no. 6800NIG).

## No. 6800T

### Vertical toggle clamp with black handle



Order no.	Size	F1 [kN]	F2 [kN]	Clamping screw	Weight [g]
557963	0	0,5	0,7	M 4x 25	60
557964	1	0,6	1,1	M 5x 30	105
557965	2	0,8	1,2	M 6x 35	175
557966	3	1,2	2,5	M 8x 45	410
557967	4	1,7	3,0	M 8x 65	630
557968	5	3,0	5,0	M12x 80	1480
557969	6	3,4	5,5	M12x110	2200

Also available in „STAINLESS STEEL“ version (no. 6800NIT).

### Recommendations



No. 6895,  
page 170



No. 6892,  
page 162



No. 6800S,  
page 64

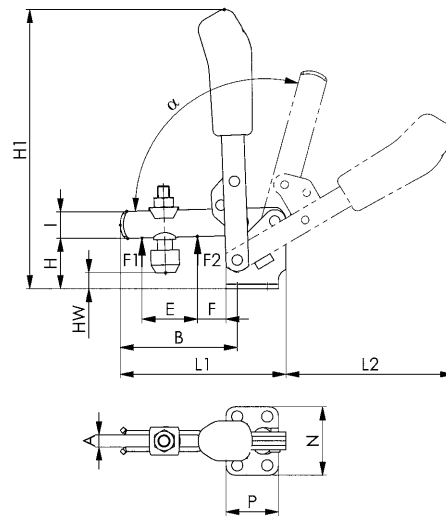

CAD

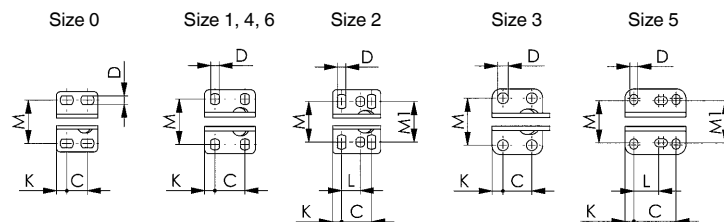

### Dimensions:

Size	A	B	C	D	E	F	H	H1	HW min.	HW max.	I	K	L	L1	L2	M	M1	N	P	α	α*
0	4	31,0	8,5-13,5	4,5	14	5,5	18,0	81,0	-1,5	3,5	8	5,5	-	49	50	23,0	-	32	22	95°	-
1	5	39,0	16,0	4,5	18	6,0	19,0	98,0	-4,0	2,0	10	5,5	-	61	58	22,5-26,0	-	34	27	95°	-
2	6	52,0	20,0	5,5	25	11,0	23,0	140,0	-3,0	4,5	12	6,0	12,5	78	89	23,0-31,0	27	43	32	105°	60°
3	8	79,0	20,0	7,5	37	19,0	33,0	186,0	2,0	11,0	18	7,5	-	112	112	32,5	-	46	35	105°	60°
4	10	101,0	32,0	8,6	54	16,0	42,5	221,0	-6,0	22,5	20	13,0	-	141	130	43,0-46,5	-	64	53	105°	60°
5	14	140,0	45,0	8,5	73	34,0	55,8	281,0	-3,0	27,5	25	9,5	26,5-31,5	195	185	45,0-50,0	45	70	65	115°	60°
6	14	165,5	50,5	13,0	89	28,0	81,0	333,0	-2,5	55,0	30	24,5	-	231	206	67,5-72,5	-	100	90	140°	60°

\* The opening angle can be changed by pressing in a stop pin.

Subject to technical alterations.

## No. 6802

### Vertical toggle clamp with red handle

with open clamping arm and vertical base.

Galvanized and passivated. Rivets made of stainless steel, which, for sizes 2 to 6, run in hardened bushings. Bearings are pre-lubricated.

Ergonomic, oil-resistant handle with large grip surface and soft components. Safety clamping piece with finger protection. Lock washer for the thrust bolt at the end of the clamping arm.

Complete with tempered, galvanized clamping screw no. 6890.



Order no.	Size	F1 [kN]	F2 [kN]	Clamping screw	Weight [g]
90217	1	0,6	1,1	M 5x 30	105
90225	2	0,8	1,2	M 6x 35	175
90233	3	1,2	2,5	M 8x 45	410
90241	4	1,7	3,0	M 8x 65	630
90258	5	3,0	5,0	M12x 80	1480
90266	6	3,4	5,5	M12x110	2200

Also available in matte-black version (no. 6802B)!

## No. 6802Y

### Vertical toggle clamp with yellow handle



Order no.	Size	F1 [kN]	F2 [kN]	Clamping screw	Weight [g]
557018	1	0,6	1,1	M 5x 30	105
557019	2	0,8	1,2	M 6x 35	175
557020	3	1,2	2,5	M 8x 45	410
557021	4	1,7	3,0	M 8x 65	630
557022	5	3,0	5,0	M12x 80	1480
557023	6	3,4	5,5	M12x110	2200

## No. 6802J

### Vertical toggle clamp with orange handle



Order no.	Size	F1 [kN]	F2 [kN]	Clamping screw	Weight [g]
557310	1	0,6	1,1	M 5x 30	105
557311	2	0,8	1,2	M 6x 35	175
557312	3	1,2	2,5	M 8x 45	410
557313	4	1,7	3,0	M 8x 65	630
557314	5	3,0	5,0	M12x 80	1480
557315	6	3,4	5,5	M12x110	2200

## No. 6802E

### Vertical toggle clamp with blue handle



Order no.	Size	F1 [kN]	F2 [kN]	Clamping screw	Weight [g]
557622	1	0,6	1,1	M 5x 30	105
557623	2	0,8	1,2	M 6x 35	175
557624	3	1,2	2,5	M 8x 45	410
557625	4	1,7	3,0	M 8x 65	630
557626	5	3,0	5,0	M12x 80	1480
557627	6	3,4	5,5	M12x110	2200

Subject to technical alterations.

## No. 6802G

### Vertical toggle clamp with green handle



Order no.	Size	F1 [kN]	F2 [kN]	Clamping screw	Weight [g]
557472	1	0,6	1,1	M 5x 30	105
557473	2	0,8	1,2	M 6x 35	175
557474	3	1,2	2,5	M 8x 45	410
557475	4	1,7	3,0	M 8x 65	630
557476	5	3,0	5,0	M12x 80	1480
557477	6	3,4	5,5	M12x110	2200

## No. 6802T

### Vertical toggle clamp with black handle



Order no.	Size	F1 [kN]	F2 [kN]	Clamping screw	Weight [g]
557970	1	0,6	1,1	M 5x 30	105
557971	2	0,8	1,2	M 6x 35	175
557972	3	1,2	2,5	M 8x 45	410
557973	4	1,7	3,0	M 8x 65	630
557974	5	3,0	5,0	M12x 80	1480
557975	6	3,4	5,5	M12x110	2200



CAD

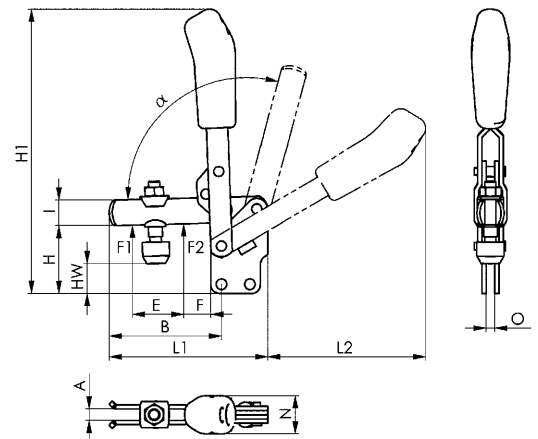

### Recommendations



No. 6891,  
page 161



No. 6802S,  
page 66

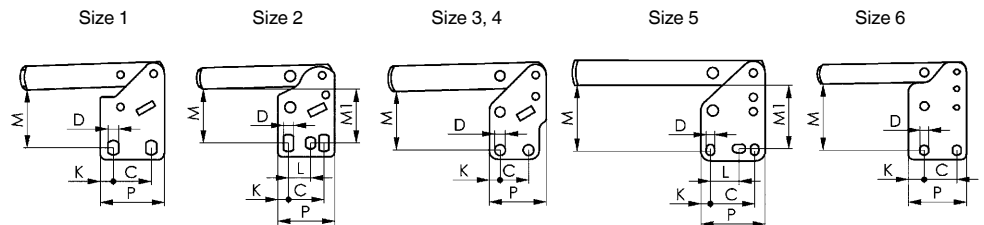

### Dimensions:

Size	A	B	C	D	E	F	H	H1	HW min.	HW max.	I	K	L	L1	L2	M	M1	N	O	P	α	α*
1	5	39	16,0	4,5	18	6	29	109,0	6,0	12,5	10	5,5	-	61	59	23,5-25,0	-	19	5	27	95°	-
2	6	52	20,0	5,5	25	11	38	144,5	11,5	19,5	12	6,0	12,5	78	80	28,5-32,0	30	21	5	32	105°	60°
3	8	79	20,0	7,5	36	19	48	200	16,5	25,0	18	7,5	-	112	114	41,0	-	27	6	40	105°	60°
4	10	101	32,0	8,6	54	16	65	244	16,5	45,5	20	13,0	-	141	130	55,5	-	35	8	53	105°	60°
5	14	140	45,0	8,5	72	35	77	301	18,0	49,0	25	9,5	26,5-31,5	195	183	66,0	64	45	10	65	115°	60°
6	14	165	50,5	13,0	89	28	117	369	33,0	90,5	30	24,5	-	231	206	102,0	-	45	10	90	140°	60°

\* The opening angle can be changed by pressing in a stop pin.

Subject to technical alterations.

## No. 6803

### Vertical toggle clamp with red handle

with open clamping arm and angle base.

Galvanized and passivated. Rivets made of stainless steel, which, for sizes 2 and 3, run in hardened bushings. Bearings are pre-lubricated.

Ergonomic, oil-resistant handle with large grip surface and soft components. Safety clamping piece with finger protection. Lock washer for the thrust bolt at the end of the clamping arm.

Complete with tempered, galvanized clamping screw no. 6890.



Order no.	Size	F1 [kN]	F2 [kN]	Clamping screw	Weight [g]
90316	1	0,8	1,1	M5x30	125
90324	2	1,0	1,2	M6x35	220
90332	3	1,4	2,5	M8x45	400
90340	4	2,0	3,0	M8x65	650

Also available in „STAINLESS STEEL“ version (no. 6803NI).

## No. 6803Y

### Vertical toggle clamp with yellow handle



Order no.	Size	F1 [kN]	F2 [kN]	Clamping screw	Weight [g]
557024	1	0,8	1,1	M5x30	125
557025	2	1,0	1,2	M6x35	220
557026	3	1,4	2,5	M8x45	400
557027	4	2,0	3,0	M8x65	650

Also available in „STAINLESS STEEL“ version (no. 6803NIY).

## No. 6803J

### Vertical toggle clamp with orange handle



Order no.	Size	F1 [kN]	F2 [kN]	Clamping screw	Weight [g]
557318	1	0,8	1,1	M5x30	125
557319	2	1,0	1,2	M6x35	220
557320	3	1,4	2,5	M8x45	400
557321	4	2,0	3,0	M8x65	650

Also available in „STAINLESS STEEL“ version (no. 6803NIJ).

## No. 6803E

### Vertical toggle clamp with blue handle



Order no.	Size	F1 [kN]	F2 [kN]	Clamping screw	Weight [g]
557630	1	0,8	1,1	M5x30	125
557631	2	1,0	1,2	M6x35	220
557632	3	1,4	2,5	M8x45	400
557633	4	2,0	3,0	M8x65	650

Also available in „STAINLESS STEEL“ version (no. 6803NIE).

Subject to technical alterations.

## No. 6803G

### Vertical toggle clamp with green handle



Order no.	Size	F1 [kN]	F2 [kN]	Clamping screw	Weight [g]
557479	1	0,8	1,1	M5x30	125
557480	2	1,0	1,2	M6x35	220
557481	3	1,4	2,5	M8x45	400
557482	4	2,0	3,0	M8x65	650

Also available in „STAINLESS STEEL“ version (no. 6803NIG).

## No. 6803T

### Vertical toggle clamp with black handle



Order no.	Size	F1 [kN]	F2 [kN]	Clamping screw	Weight [g]
557977	1	0,8	1,1	M5x30	125
557978	2	1,0	1,2	M6x35	220
557979	3	1,4	2,5	M8x45	400
557980	4	2,0	3,0	M8x65	650

Also available in „STAINLESS STEEL“ version (no. 6803NIT).

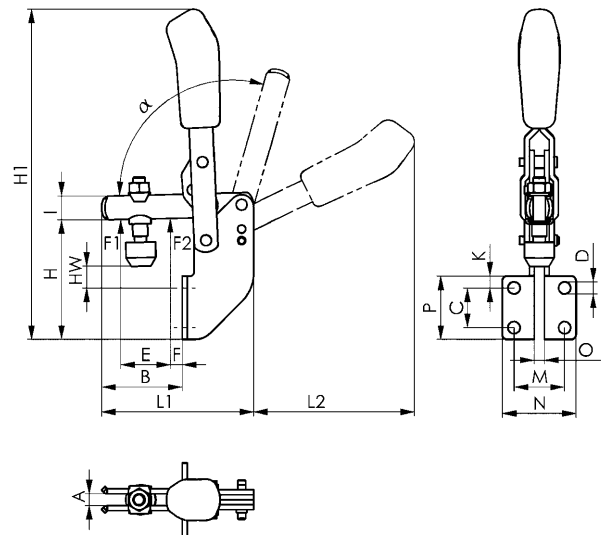
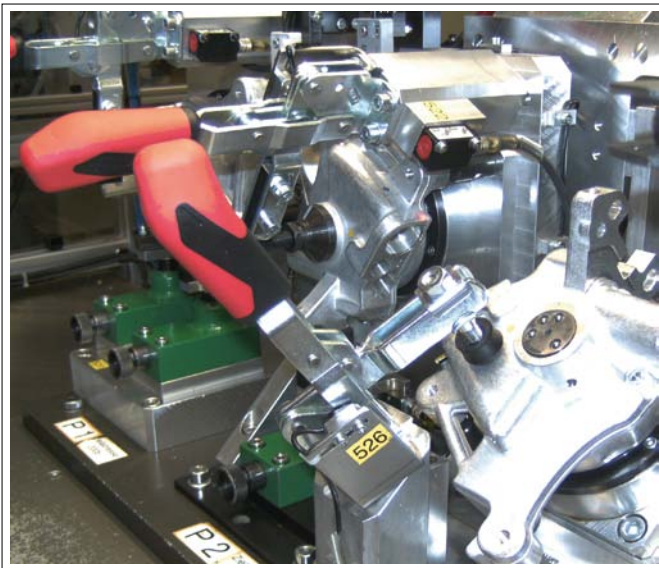

### Recommendations



No. 6895,  
page 170



No. 6896,  
page 163



No. 6803S,  
page 68

### Dimensions:

Size	A	B	C	D	E	F	H	H1	HW min.	HW max.	I	K	L1	L2	M	N	O	P	$\alpha$	$\alpha^*$
1	5	34,5	14	4,5	18	7	45,0	125,0	2,5	9,0	10	10	61	58	20,0	30,0	5	30	98°	-
2	6	41,0	20	6,1	25	6	60,0	176,5	8,0	15,5	12	6	77	90	25,5	37,0	5	32	105°	60°
3	8	62,0	24	6,5	37	11	71,0	223,0	9,0	17,5	18	7	110	112	28,5	42,5	6	38	105°	60°
4	10	83,0	32	8,5	54	11	101,5	280,0	11,0	39,5	20	54	141	129	32,0	52,0	8	96	105°	60°

\* The opening angle can be changed by pressing in a stop pin.

Subject to technical alterations.

## No. 6804

### Vertical toggle clamp with red handle with solid arm and horizontal base.

Galvanized and passivated.

Stainless steel rivets, which run in hardened bushes. Bearings are pre-lubricated.

Ergonomic, oil-resistant handle with large grip surface and soft components. Safety clamping piece with finger protection.

Complete with tempered, galvanized clamping screw no. 6885 and sleeve to weld on.



Order no.	Size	F1 [kN]	F2 [kN]	Clamping screw	Weight [g]
90431	3	1,4	2,5	M8x45	340
90449	4	2,0	3,0	M8x65	585
90456	5	3,0	5,0	M12x80	1480
90464	6	3,5	5,5	M12x110	2200

## No. 6804Y

### Vertical toggle clamp with yellow handle



Order no.	Size	F1 [kN]	F2 [kN]	Clamping screw	Weight [g]
557028	3	1,4	2,5	M8x45	340
557029	4	2,0	3,0	M8x65	585
557030	5	3,0	5,0	M12x80	1480
557031	6	3,5	5,5	M12x110	2200

## No. 6804J

### Vertical toggle clamp with orange handle



Order no.	Size	F1 [kN]	F2 [kN]	Clamping screw	Weight [g]
557322	3	1,4	2,5	M8x45	340
557323	4	2,0	3,0	M8x65	585
557324	5	3,0	5,0	M12x80	1480
557325	6	3,5	5,5	M12x110	2200

## No. 6804E

### Vertical toggle clamp with blue handle



Order no.	Size	F1 [kN]	F2 [kN]	Clamping screw	Weight [g]
557635	3	1,4	2,5	M8x45	340
557636	4	2,0	3,0	M8x65	585
557637	5	3,0	5,0	M12x80	1480
557638	6	3,5	5,5	M12x110	2200

Subject to technical alterations.

## No. 6804G

### Vertical toggle clamp with green handle



Order no.	Size	F1 [kN]	F2 [kN]	Clamping screw	Weight [g]
557483	3	1,4	2,5	M8x45	340
557484	4	2,0	3,0	M8x65	585
557485	5	3,0	5,0	M12x80	1480
557486	6	3,5	5,5	M12x110	2200

## No. 6804T

### Vertical toggle clamp with black handle



Order no.	Size	F1 [kN]	F2 [kN]	Clamping screw	Weight [g]
557981	3	1,4	2,5	M8x45	340
557982	4	2,0	3,0	M8x65	585
557983	5	3,0	5,0	M12x80	1480
557984	6	3,5	5,5	M12x110	2200

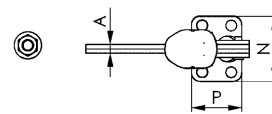
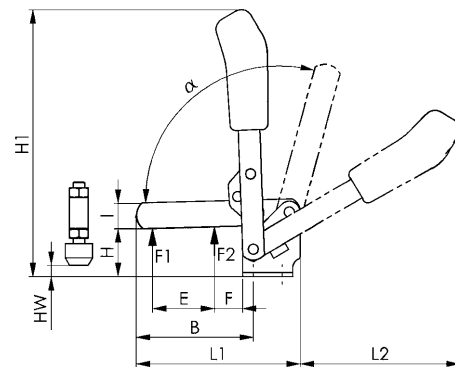
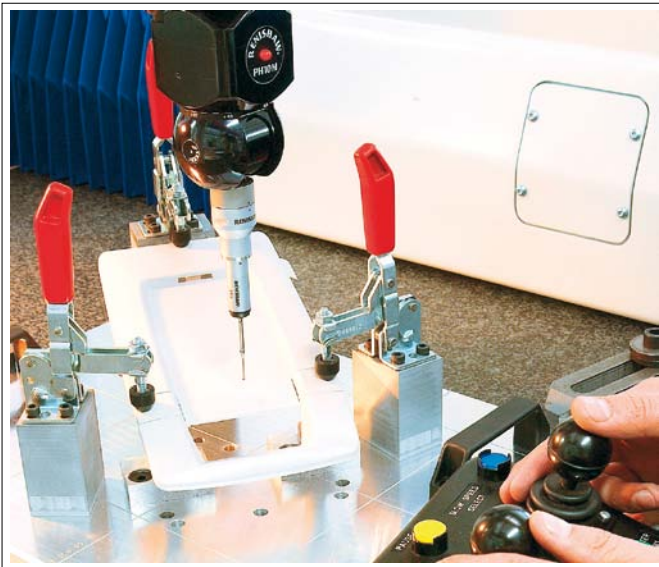

Size 3, 4, 6

Size 5

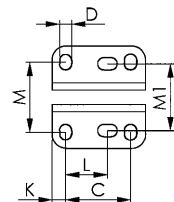
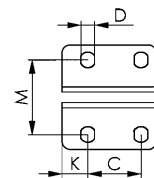

### Recommendations



No. 6886,  
page 161



No. 6805,  
page 22



No. 6804S,  
page 70

### Dimensions:

Size	A	B	C	D	E	F	H	H1	HW min.	HW max.	I	K	L	L1	L2	M	M1	N	P	$\alpha$	$\alpha^*$
3	6	81,0	20,0	7,5	43	19,5	33,5	186	0	12,0	18	7,5	-	108,5	116,5	32,5	-	46	35	105°	60°
4	8	101,0	32,0	8,6	61	17,0	42,5	221	-8	21,0	20	13,0	-	141,5	129,5	45,0	-	64	53	105°	60°
5	10	141,0	45,0	8,5	88	30,5	55,5	281	-6	25,5	25	9,5	26,5-31,5	196,5	184,0	45-50	45	70	65	115°	60°
6	10	166,5	50,5	13,0	90	20,5	81,0	331	-5	51,0	30	24,5	-	232,0	206,0	68-72	-	100	90	140°	60°

\* The opening angle can be changed by pressing in a stop pin.

Subject to technical alterations.



## No. 6806

### Vertical toggle clamp with red handle

with solid arm and vertical base.

Galvanized and passivated.

Stainless steel rivets, which run in hardened bushes. Bearings are pre-lubricated.

Ergonomic, oil-resistant handle with large grip surface and soft components. Safety clamping piece with finger protection.

Complete with tempered, galvanized clamping screw no. 6885 and sleeve to weld on.



Order no.	Size	F1 [kN]	F2 [kN]	Clamping screw	Weight [g]
90555	3	1,4	2,5	M 8x 45	400
90563	4	2,0	3,0	M 8x 65	585
90571	5	3,0	5,0	M12x 80	1480
90589	6	3,5	5,5	M12x110	2200

## No. 6806Y

### Vertical toggle clamp with yellow handle



Order no.	Size	F1 [kN]	F2 [kN]	Clamping screw	Weight [g]
557032	3	1,4	2,5	M 8x 45	400
557033	4	2,0	3,0	M 8x 65	585
557034	5	3,0	5,0	M12x 80	1480
557035	6	3,5	5,5	M12x110	2200

## No. 6806J

### Vertical toggle clamp with orange handle



Order no.	Size	F1 [kN]	F2 [kN]	Clamping screw	Weight [g]
557326	3	1,4	2,5	M 8x 45	400
557327	4	2,0	3,0	M 8x 65	585
557328	5	3,0	5,0	M12x 80	1480
557329	6	3,5	5,5	M12x110	2200

## No. 6806E

### Vertical toggle clamp with blue handle



Order no.	Size	F1 [kN]	F2 [kN]	Clamping screw	Weight [g]
557650	3	1,4	2,5	M 8x 45	400
557651	4	2,0	3,0	M 8x 65	585
557652	5	3,0	5,0	M12x 80	1480
557653	6	3,5	5,5	M12x110	2200

Subject to technical alterations.

## No. 6806G

### Vertical toggle clamp with green handle



Order no.	Size	F1 [kN]	F2 [kN]	Clamping screw	Weight [g]
557487	3	1,4	2,5	M 8x 45	400
557488	4	2,0	3,0	M 8x 65	585
557489	5	3,0	5,0	M12x 80	1480
557490	6	3,5	5,5	M12x110	2200

## No. 6806T

### Vertical toggle clamp with black handle



Order no.	Size	F1 [kN]	F2 [kN]	Clamping screw	Weight [g]
557985	3	1,4	2,5	M 8x 45	400
557986	4	2,0	3,0	M 8x 65	585
557987	5	3,0	5,0	M12x 80	1480
557988	6	3,5	5,5	M12x110	2200

### Recommendations



No. 6886,  
page 161



No. 6802,  
page 14



No. 6804,  
page 18

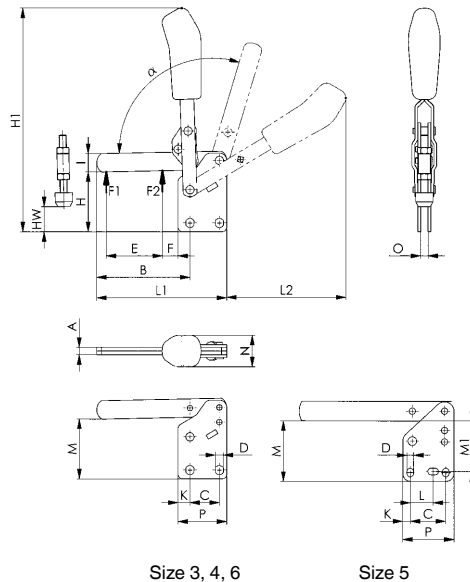

CAD

Size 3, 4, 6

Size 5

### Dimensions:

Size	A	B	C	D	E	F	H	H1	HW min.	HW max.	I	K	L	L1	L2	M	M1	N	O	P	α	α*
3	6	81,0	20,0	7,5	43	19,5	48	200	14,5	26,0	18	7,5	-	108,5	111,0	41,0	-	27	6	35	105°	60°
4	8	101,0	32,0	8,6	61	17,0	65	244	13,0	44,0	20	13,0	-	141,5	129,5	55,5	-	34	8	53	105°	60°
5	10	141,0	45,0	8,5	88	30,5	77	302	15,0	47,0	25	9,5	26,5-31,5	196,5	184,0	66,0	64	36	10	65	115°	60°
6	10	166,5	50,5	13,0	90	20,5	117	369	28,5	86,5	30	24,5	-	232,0	206,0	102,0	-	39	10	90	140°	60°

\* The opening angle can be changed by pressing in a stop pin.

Subject to technical alterations.

## No. 6805

### Vertical toggle clamp with red handle clamping arm with fixed distance of clamping screw and horizontal base.

Galvanized and passivated. Stainless steel rivets. Bearings are pre-lubricated. Ergonomic, oil-resistant handle with large grip surface and soft components. Safety clamping piece with finger protection. Complete with tempered, galvanized clamping screw no. 6885.



Order no.	Size	F1 [kN]	Clamping screw	Weight [g]
90514	1	1	M5x30	100

## No. 6805Y

### Vertical toggle clamp with yellow handle



Order no.	Size	F1 [kN]	Clamping screw	Weight [g]
557037	1	1	M5x30	100

## No. 6805J

### Vertical toggle clamp with orange handle



Order no.	Size	F1 [kN]	Clamping screw	Weight [g]
557330	1	1	M5x30	100

## No. 6805E

### Vertical toggle clamp with blue handle



Order no.	Size	F1 [kN]	Clamping screw	Weight [g]
557654	1	1	M5x30	100

Subject to technical alterations.

## No. 6805G

Vertical toggle clamp with green handle



Order no.	Size	F1 [kN]	Clamping screw	Weight [g]
557491	1	1	M5x30	100

## No. 6805T

Vertical toggle clamp with black handle



Order no.	Size	F1 [kN]	Clamping screw	Weight [g]
557989	1	1	M5x30	100

### Recommendations



No. 6886,  
page 161



No. 6804,  
page 18

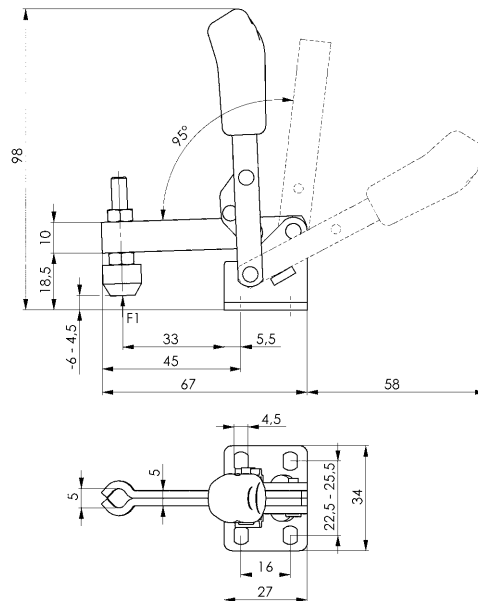

CAD

## No. 6811P

### Heavy vertical toggle clamp

with horizontal base.

Reamed and case-hardened bearing bushes.

Hardened, ground and permanently-lubricated pins. Clamp nuts

on lever arm to vary friction in movement. Material: steel, blued.

Lever arm made of cast steel, blued. Handle of red, oil-resistant

plastic.

Complete with tempered, galvanized clamping screw

no. 6885.



CAD

Order no.	Size	F1 [kN]	Clamping screw	Weight [g]
91314	2	2,5	M 6x 50	320
90878	4	5,0	M12x 80	1250
90886	6	6,0	M12x110	2130
90894	8	12,0	M12x110	4050

### Note:

These heavy vertical toggle clamps are especially suitable for production equipment and fixtures.

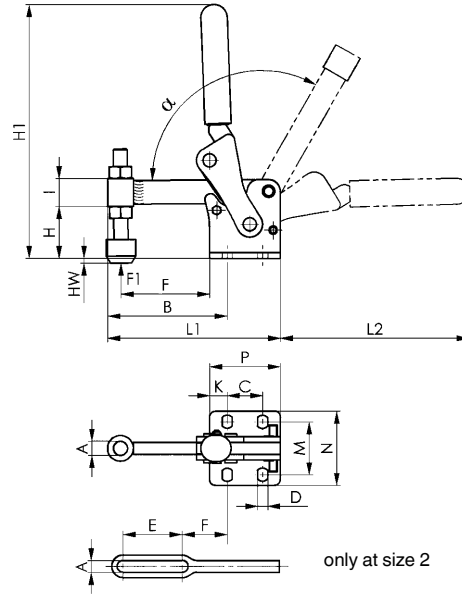

### Recommendations



No. 6805,  
page 22



No. 6812P,  
page 25

### Dimensions:

Order no.	Size	A	B	C	D	E	F	H	H1	HW min.	HW max.	I	K	L1	L2	M	N	P	$\alpha$
91314	2	6,1	57	20	7,1	30	21	25	127	-13,5	6	15	8,5	85	94	32	47	37	120°
90878	4	12,2	100	30	8,5	-	75	44	216	-19,0	14	24	15	146	160	45	65	60	120°
90886	6	12,2	121	45	10,5	-	95	65	263	-22,0	35	30	15	181	185	52	78	75	120°
90894	8	12,2	151	55	12,5	-	120	71	303	-10,0	41	36	20	226	203	75	108	95	120°



Subject to technical alterations.

## No. 6812P

### Heavy vertical toggle clamp

with vertical base and mounting holes.

Reamed and case-hardened bearing bushes.

Hardened, ground and permanently-lubricated pins. Clamp nuts on lever arm to vary friction in movement. Material: steel, blued.

Lever arm made of cast steel, blued. Handle of red, oil-resistant plastic.

Complete with tempered, galvanized clamping screw no. 6885.



CAD

Order no.	Size	F1 [kN]	Clamping screw	Weight [g]
91330	2	2,5	M 6x 50	320
90902	4	10,0	M12x 80	1320
90910	6	12,0	M12x110	2120
90928	8	20,0	M12x110	4060

### Note:

These heavy vertical toggle clamps are especially suitable for production equipment and fixtures.

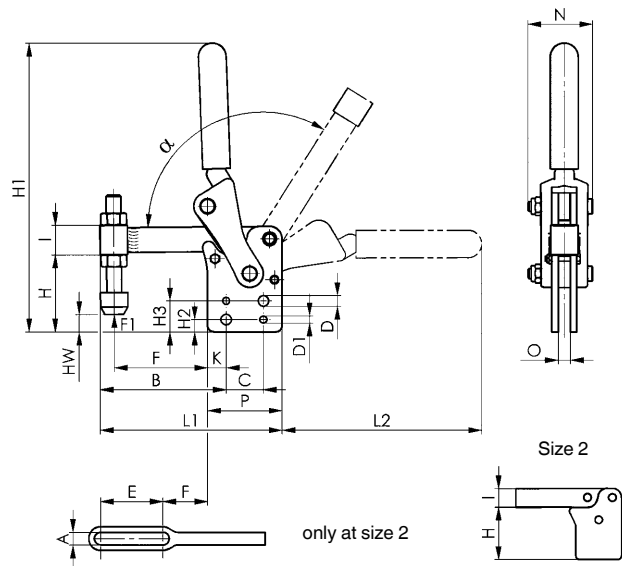

### Recommendations



No. 6802,  
page 14



No. 6806,  
page 20



No. 6811P,  
page 24

### Dimensions:

Order no.	Size	A	B	C	D	D1	E	F	H	H1	H2	H3	HW min.	HW max.	I	K	L1	L2	N	O	P	$\alpha$
91330	2	6,2	48	-	-	-	30	12	42,0	144	-	-	3,5	22,8	15	-	85	94	31	6	37	190°
90902	4	12,2	101	30	8,5	5,7	-	75	62,0	233	10	25	-1,0	35,0	24	15	146	161	52	10	60	120°
90910	6	12,2	121	45	10,5	7,7	-	95	87,5	289	15	35	0,0	58,0	30	15	181	189	60	12	75	120°
90928	8	12,2	151	55	12,5	9,7	-	120	106,0	338	15	40	25,0	76,0	36	20	226	219	76	16	95	120°

## No. 6809P

### Modular clamp

with swivelling foot, welding version.

Mechanism can be welded at an angle to its support.  
Reamed and case-hardened bearing bushes. Hardened, ground and permanently-lubricated pins. Clamp nuts on lever arm to vary friction in movement.

Materials: steel, blued. Lever arm made of cast steel, blued.



CAD

Order no.	Size	F1	Weight [g]
		[kN]	
90738	2	2,5	205
90746	4	7,0	855
90753	6	11,0	1600
90761	8	22,5	3100
90779	10	34,0	5560

### Note:

These modular clamps can be supplemented with accessories just as you need to meet the requirements of your production equipment and fixtures.

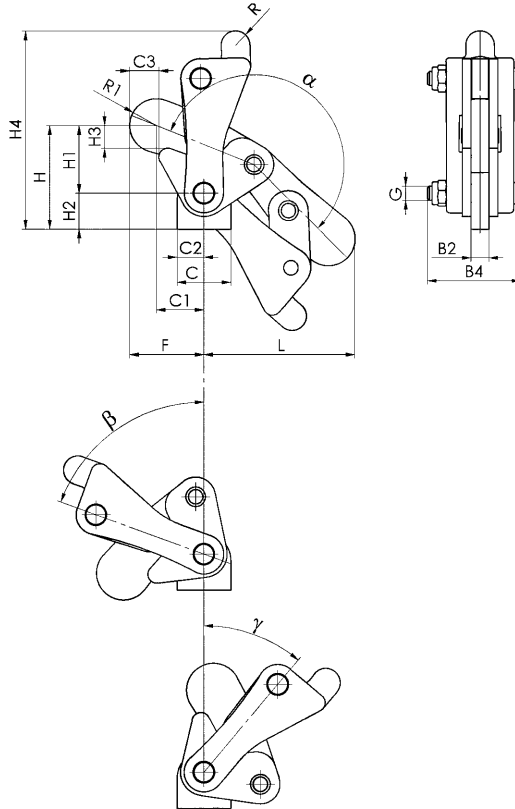

### Installation instruction:

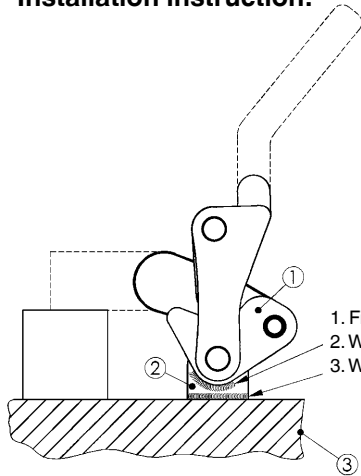

1. Fix modular clamp in clamping position
2. Weld part ① to part ②
3. Weld part ② to part ③

### Recommendations



No. 6809H,  
page 28

No. 6809RK,  
page 28

No. 6809RL,  
page 28

### Dimensions:

Order no.	Size	B2	B4	C	C1	C2	C3	F	G	H	H1	H2	H3	H4	L	R	R1	$\alpha$	$\beta$	$\gamma$
90738	2	6	31	22	22	11	12	32	M 6	38	18	20,0	5	76	58	5	10,0	200°	70°	40°
90746	4	10	52	30	26	15	16	41	M 8	58	38	20,0	12	112	82	8	15,0	200°	70°	40°
90753	6	12	60	36	36	18	20	55	M10	78	50	28,0	16	145	105	11	18,0	200°	70°	40°
90761	8	16	76	50	50	25	27	72	M12	98	65	33,0	19	172	135	14	22,5	200°	70°	40°
90779	10	20	90	70	52	35	22	77	M16	117	83	33,5	25	210	155	14	25,0	200°	60°	28°

Subject to technical alterations.

## No. 6810P

### Modular clamp

with vertical foot, welding version.

Reamed and case-hardened bearing bushes.

Hardened, ground and permanently-lubricated pins. Clamp nuts on lever arm to vary friction in movement.

Materials: steel, blued. Lever arm made of cast steel, blued.



Order no.	Size	F1 [kN]	Weight [g]
90803	2	2,5	245
90811	4	7,0	970
90829	6	11,0	1750
90837	8	22,5	3310
90845	10	34,0	5970

### Note:

These modular clamps can be supplemented with accessories just as you need to meet the requirements of your production equipment and fixtures.

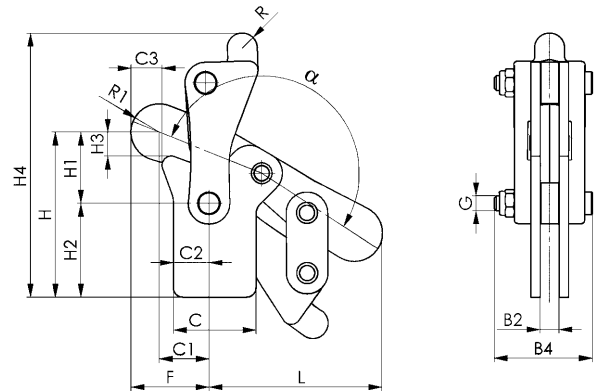

### Recommendations



No. 6809G,  
page 29



No. 6809S,  
page 29



No. 6809V,  
page 29

### Dimensions:

Order no.	Size	B2	B4	C	C1	C2	C3	F	G	H	H1	H2	H3	H4	L	R	R1	α
90803	2	6	31	30	22	14	12	32	M 6	52	18	34	5	90	58	5	10,0	190°
90811	4	10	52	44	26	19	16	41	M 8	88	38	50	12	142	82	8	15,0	190°
90829	6	12	60	55	36	28	20	55	M10	114	50	64	16	182	106	11	18,0	190°
90837	8	16	76	66	50	37	27	72	M12	140	64	76	19	218	135	14	22,5	190°
90845	10	20	90	80	52	40	22	77	M16	173	83	90	25	266	155	14	25,0	190°



## No. 6809H

### Hand grip

Red, oil-resistant plastic.



CAD

Order no.	Size	ØD x H	Weight [g]
91355	2	13 x 50	7
91363	4	18 x 90	21
91371	6	22 x 100	28
91389	8+10	28 x 110	39

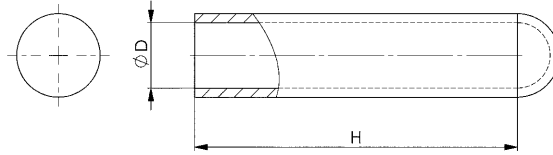

## No. 6809RK

### Lever arm tube, short

For welding, chamfered to protect operator's hands. Steel, blued.



CAD

Order no.	Size	ØD x H	Weight [g]
91033	2	13 x 55	37
91041	4	18 x 95	104
91058	6	22 x 105	148
91066	8+10	28 x 115	148

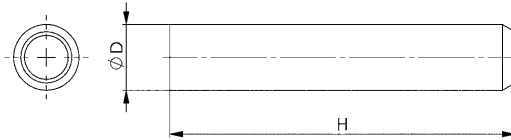

## No. 6809RL

### Lever arm tube, long

For welding, chamfered to protect operator's hands. Steel, blued.



CAD

Order no.	Size	ØD x H	Weight [g]
91074	2	13 x 95	60
91082	4	18 x 120	132
91090	6	22 x 150	211
91108	8+10	28 x 180	333

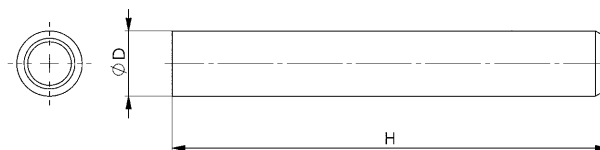

Subject to technical alterations.

## No. 6809G

### Base plate

For welding, with mounting holes. Steel, blued.



CAD

Order no.	Size	C	dia. D	M	N	P	S	Weight [g]
90944	2+4	25	6,5	35	50	40	8	86
90951	6	40	8,5	30	50	60	8	211
90969	8	50	8,5	45	65	70	8	333
90977	10	60	10,5	50	70	80	10	406

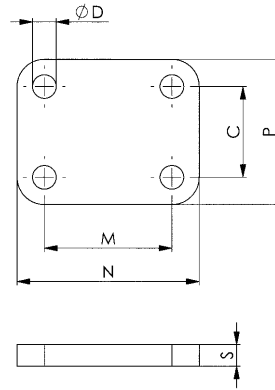

## No. 6809S

### Clamping screw holder

For welding, thick-walled. Steel, blued.



CAD

Order no.	Size	ØD x H	Weight [g]
91116	2	6,5 x 20	26
91124	4	12,1 x 24	50
91132	6	12,1 x 30	63
91173	8+10	12,1 x 36	75

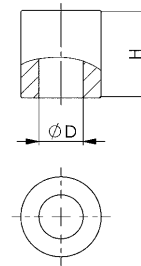

## No. 6809V

### Clamping arm extension

For welding, slotted. Steel, blued.



CAD

Order no.	Size	L x H x W	Weight [g]
90985	2	40 x 15 x 15	81
90993	4	48 x 25 x 20	208
91009	6	60 x 30 x 25	390
91017	8	75 x 35 x 30	676
91025	10	94 x 35 x 35	970

