

MACHINE MODEL

BS 300/60 SHI

Semiautomatic saw for tubes and profiles

Short description

BS 300/60 SHI is the semiautomatic sawing machine for cutting tubes, profiles, bars of medium size. Due to its small size and ease of use, it can be used in any mechanical workshop and work environment. It is suitable for cutting high resistance materials.



Scan the video

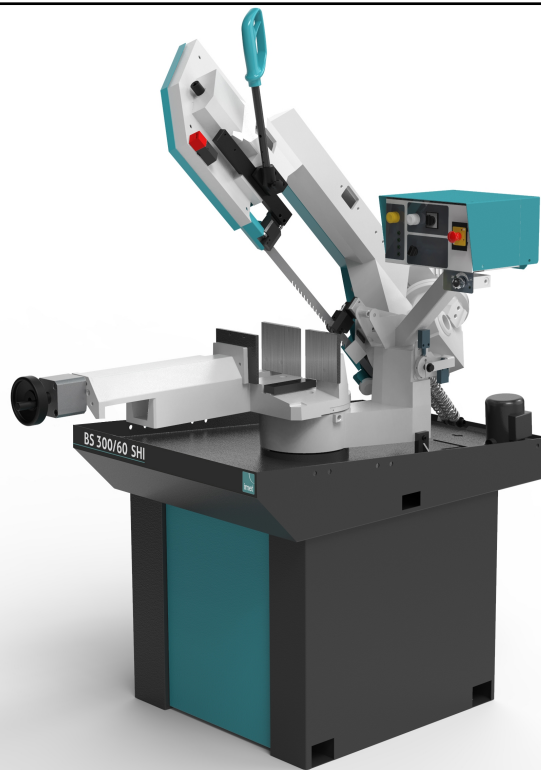

Cutting capacity at 0°	Round: 255mm - Square: 240mm - Rectangular: 300x180mm
Cutting capacity at 45°	Round: 210mm - Square :190mm - Rectangular: 200x160mm
Cutting capacity at 60°	Round: 135mm - Square :110mm - Rectangular: 130x100mm
Cutting capacity at 0° for solids (C45)	200mm
Motor power	1.5KW
Blade speed	35/70 m/min
Height of the work surface	940mm
Bimetal band saw blade	2765x27x0.9mm
Weight	320kg
Dimensions	1050x1700x1860mm

Features

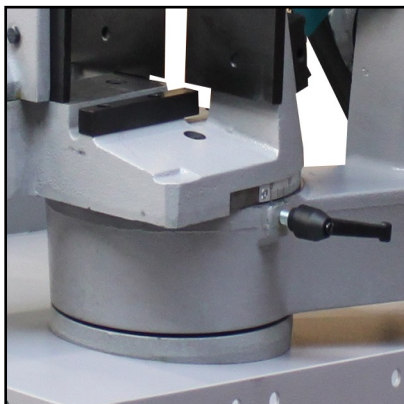

Automatic stop system

BS 300/60 SHI can cut up to 60 ° to the left and cutting operations are favored by the presence of a system of automatic stops at 0 °, 45 ° and 60 ° during cutting and a graduated scale on the work surface.

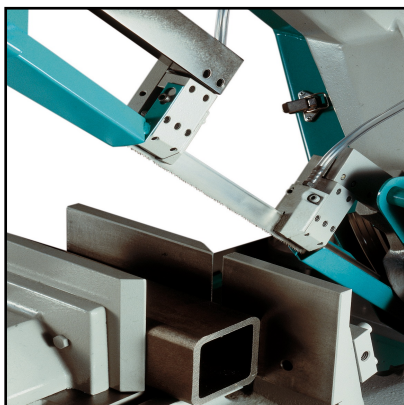

Blade alignment

BS 300/60 SHI is equipped with blade guide with hard metal pads and additional front bearings to optimize the blade alignment when cutting.

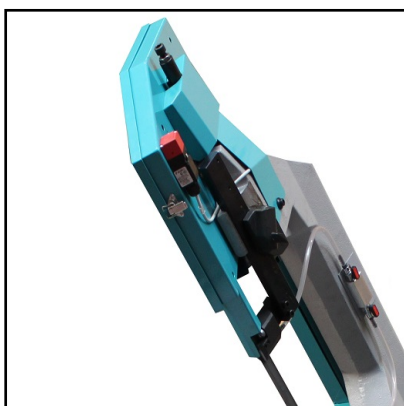

Cutting sawframe

The bow of the BS 300/60 SHI is in cast iron with tubular section, 320mm pulleys and hinged blade guard to facilitate the blade replacement.



Control panel

Fully electronic, the control panel of the BS 300/60 SHI allows you to interrupt the process of cutting at any time, in case of need, with operation control levers .

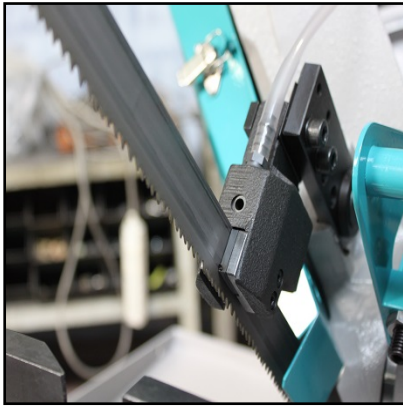

Blade

BS 300/60 SHI bimetal band saw blade has dimensions of 2765x27x0.9mm, very high tension at 1700kg/cm² with easy front adjustment, 1.5KW motor with a speed of 35/70 m / min.



Minimal lubrication system (Optional)

OPTIONAL

It is possible to request for any type of machine the minimum lubrication that eliminates the dispersion of typical coolant in the use of emulsifiable oil. The life of the blade is not affected in any way.



Laser ray (Optional)

OPTIONAL

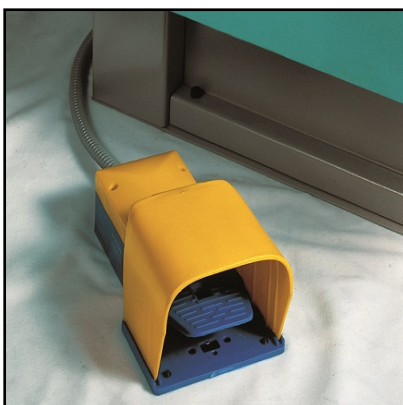

Foot pedal (Optional)

OPTIONAL

Foot control for the semiautomatic saw BS 300/60 SHI with cable and plug for connection to the panel.



Loading / unloading roller table(Optional)

OPTIONAL

Loading/unloading roller table 1st element ,2m long, capacity 700 kg .



Roller table for loading / unloading side(Optiona)

OPTIONAL

Loading/unloading roller table, following element 2m long, capacity 600 kg .

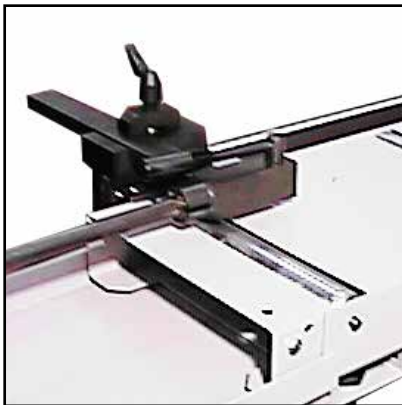

Roller table for unloading side with millimeter rod (Optional)

OPTIONAL

First element for a roller table compatible with the unloading side. The roller table is equipped with metric rod and length stop ,2m long, capacity 700kg.

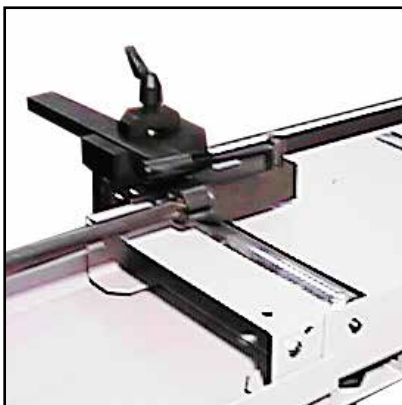

Roller table for unloading side with millimeter rod (Optional)

OPTIONAL

Following element for a roller table compatible with the unloading side. The roller table is equipped with metric rod and length stop . 2m long ,capacity 600kg.



sawing technology

IMET SPA
Località tre fontane, 6 - 24034
Cisano Bergamasco (BG) Italy
Tel +39 035 4387911 | Fax +39 035 787066
imet@imetsaws.com
www.imetsaws.com

BS 300/60 SHI



Unloading table: digital reading and manual position (optional) **OPTIONAL**

Roller table compatible with the unloading side with digital reading system and manual positioning. Availability : -RTL3W30 measurement length 3m, 3legs ,max capacity 3000kg; -RTL6W30 measurement length 6m, 5legs ,max capacity 6000kg; -RTL9W30 measurement length 9m, 7legs ,max capacity 9000kg;