

MACHINE MODEL

CUBO400 NC FLAT

Automatic bandsaws with CNC for batch production

Short description

CUBO 400 NC FLAT is an automatic bandsaws with CNC suitable to be a professional working tool for batch production of tubes, bars, profiles and solids. The machine bow rotation is manual while the automatic feeder is integrated. Thanks to INDUSTRY 4.0 READY optional, the user can control its machine remotely (or with the 7" integrated touch screen display)



Cutting capacity at 0°	Round: 310mm - Square: 280mm - Rectangular: 400x250mm
Cutting capacity at 45° sinistra	Round: 280mm - Square: 270mm - Rectangular: 300x200mm
Cutting capacity at 60° sinistra	Round: 210mm - Square: 200mm - Rectangular: 200x200mm
Cutting capacity with bundle cutting	Max: 300x160mm - Min: 85x10mm
Cutting capacity at 0° with solids (C45)	250mm
Blade size	4020x34x1.1mm
Blade motor	2.2KW
Blade speed	18-100m/min
Minimum cutting length (automatic)	15mm
Feeder single stroke	515mm
Feeder motor power	0,75KW
Minimum scrap end	80mm
Working area height	890mm
Weight	990kg
Size	1850x2200x1990mm

Features



Touch screen display

Automatic IMET bandsaws have touch screen display (7" in this version) that allows to manage, set and view all functioning settings with just few clicks. The interface is intuitive, simple and easy-to-use, so that the user can easily set cutting lines and programs, have a self-diagnosis to detect errors. The CNC system allows to set up to 99 programs, 10 lengths for each bars while the cutting length range goes from 4mm to 9999mm with automatic stroke repetition.

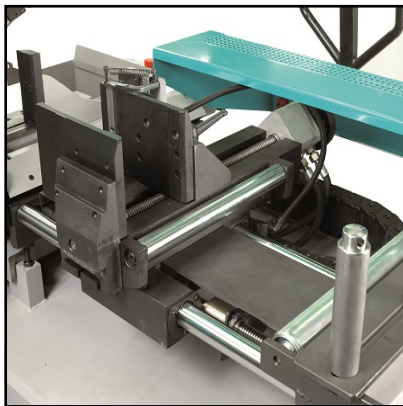

Feeder

Machine has an integrated feeder with 515mm single stroke. The feeder is on floating plate that allows to load also not-rectilinear bars. Full stroke on tempered guides for highest positioning precision.

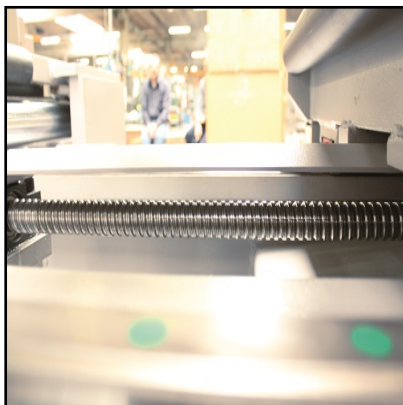

Positioning precision

The incremental screws provides for the highest positioning precision. The movement is provided by electric motor with inverter, econcoder and recyrculating ballscrew.



Mechanical detect device.

CUBO 400 NC FLAT is equipped with a mechanical detect device for material detection while starting the cut to optimize the cutting process: the device ease the sawframe fast approach to the material, regulating also the end cut, blade penetration and blade rising once the process ends.

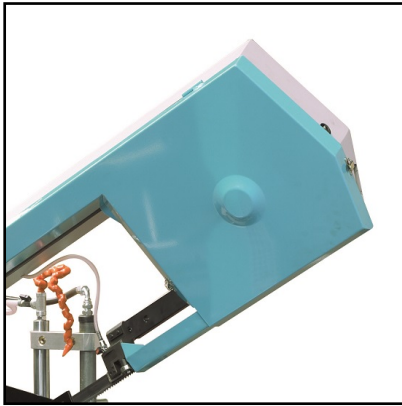

Steel sawframe

IMET bandsaws have strong and rigid steel sawframe with tubular section to give maximum resistance while cutting. Blade alignment guaranteed by mobile hard pads blade guides. This strong structure allows to reduce vibration and bindings while cutting, increasing cutting performances.



Blade speed

Automatic bandsaws produced by Imet are standardly equipped with electronic inverter for speed variation speed that increase speed range to 18-100 m/min. BS 400/60 AFI-NC blade motor has 2.2kw power with motor reducer.

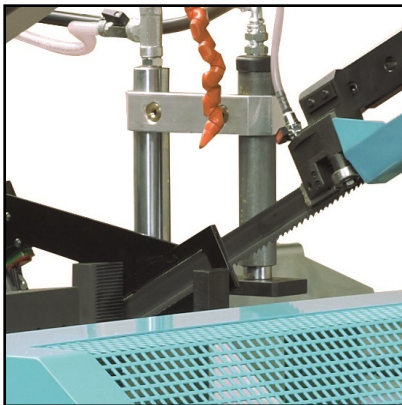

Blade 34mm

CUBO 400 NC FLAT uses a blade 34mm to optimize cutting performances and times: with this blade and its motor reducer the machines has a perfect material penetration even on bigger profiles (and solid materials up to 250mm with C45 steels)



Blade cleaning

All Imet semiautomatic and automatic machine mount as standard a motorized metal brush with nylon teeth.



Industry 4.0 Ready (Optional)

OPTIONAL

IMET automatic machines can be connected to the company network and be used remotely thanks to SAWFACTORY and modem. SAWFACTORY is a dedicated software which allows to manage the cutting process from the office desk by setting cutting programs and monitoring the workflow thanks to the dedicated web app. The software also allows to also receive assistance by our technicians remotely. Discover SAWFACTORY: <https://bit.ly/2RuxHuX>

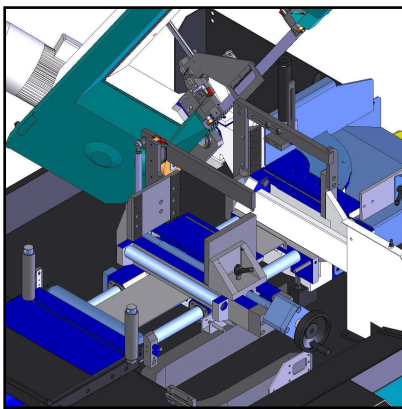

Bundle cutting device for CUBO (Optional)

OPTIONAL

The CUBO automatic band saws in the BOX version can be used with the bundle cutting device. The bundle cut can only be used for 0° cutting. Single piece capacity with mounted device: 350x160mm max, 55x10mm min. Cutting capacity for bundle is: max 300x160mm, minimum 85x10mm. The device can be disassembled using the 2 screws on the fixed vice and the 2 on the carriage vice and disconnecting the hydraulic tubes using the quick couplings systems.



Minimal lubrication system (Optional)

OPTIONAL

Minimal lubrication system to avoid any coolant dispersion, keeping working area perfectly clean so that the machine can always work in the most efficient way; it works thanks to automatic switch and it has 2 nozzle and 1.3 l tank capacity.



Motorized chip conveyor (Optional)

OPTIONAL

It's available for all the CUBO SERIES automatic bandsaw an optional motorized chip conveyor placed laterally (on the loading side) of the machine. The chip conveyor allows to optimize the machine efficiency by removing remainings and chips while cutting.



Automatic saw rotation with mechanical stops (optional) OPTIONAL

CUBO 400 NC (Flat and Box) are compatible with the automatic sawframe rotation device. The system has mechanical stops with 2 positions and allows to optimize user workflow with mitre cutting on a same bare in automatic cycle. Link: <https://youtu.be/wZAJSwT6x3Y>



Laser ray (Optional) OPTIONAL

To ease the working process, it's possibile to require di special laser ray that points the cutting line on the material before starting to operate.



Angle display (Optional) OPTIONAL

It's possible to view the set angle throught a digital display on panel control.

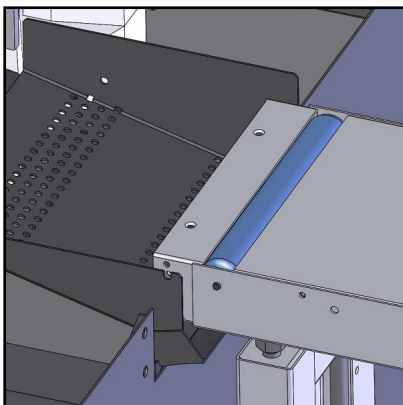

Connection element for roller table (Optional) OPTIONAL

Connection element for loading side to connect the RTS roller table with the machine.



Loading/unloading roller table (Optional)

OPTIONAL

Loading and unloading roller table with free rolls. First element.



Roller table with free rolls (Optional)

OPTIONAL

Following element for roller table with free rolls for loading and unloading side.



Containment vertical rollers (Optional)

OPTIONAL

Pair of containment vertical roller in steel. Max 2 pairs every 1.5m