

Z series

Z series screw jacks are the preferred range with the largest number of types. The Z series features through holes for top mounting and integral pivot bearings, features not available on the GSZ series.

Pivot bearing

Top mounting

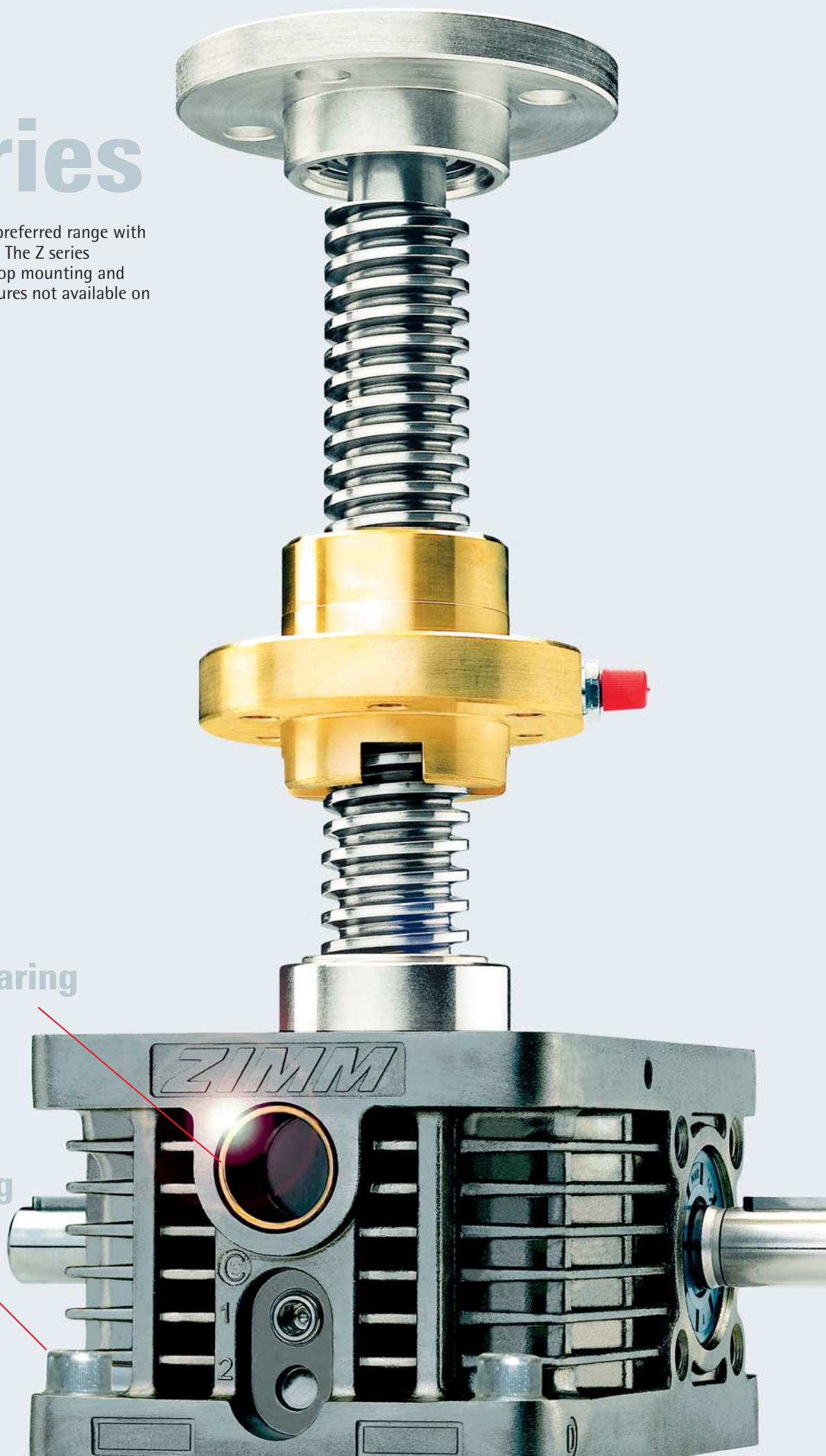

Types and sizes

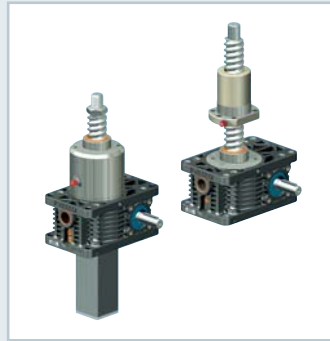
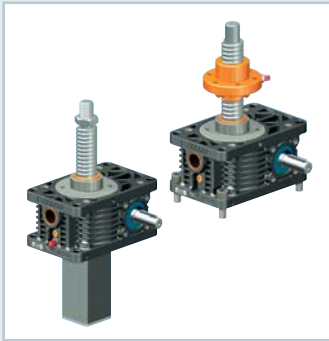

Z series jacks Tr
Trapezoidal screw
5 kN to 1,000 kN

Pages 14 - 39



Z series jacks KGT
Ball screw
5 kN to 1,000 kN

Pages 40 - 49



Z series jacks SIFA
Safety nut
5 kN to 1,000 kN

Pages 50 - 55



We have patents registered or pending for a range of functions and components.



UNIQUE:
Screw lubrication
during operation

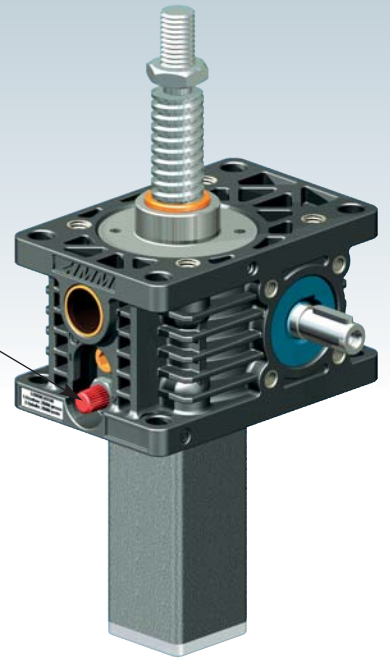

Z-5-S translating screw 5 kN

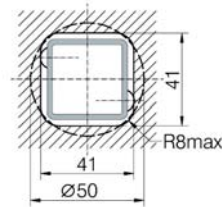
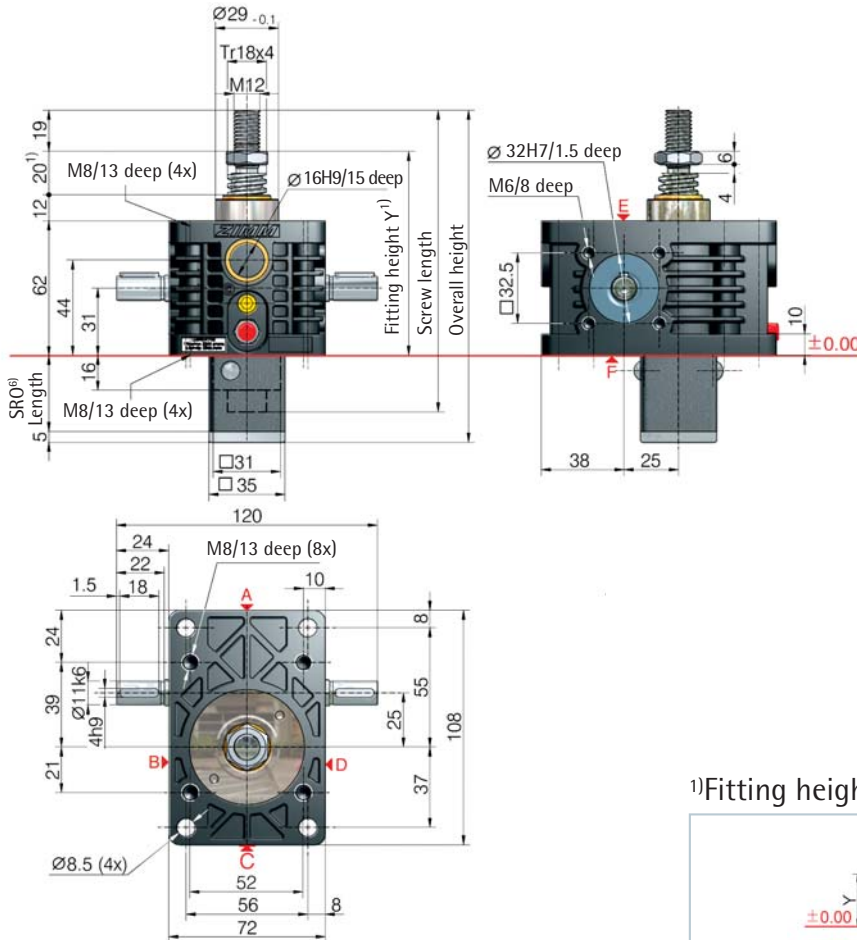

Opening for protective tube SRO, square 41x41 or round Ø 50

1) Fitting height for 0-stroke, with Tr 18x4 screw

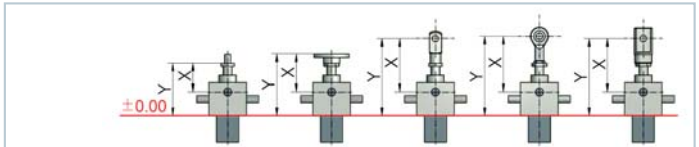

All dimensions in mm

Bellocs FB	X/Y	X/Y	X/Y	X/Y	X/Y
without bellocs FB	50/94	70/114	98/142	100/144	98/142
Z-5-FB-265	83/127	83/127	131/175	133/177	111/155
Z-5-FB-500	148/192	148/192	196/240	198/242	176/220
Z-5-FB-800	168/212	168/212	216/260	218/262	196/240

*with bellows fixing ring Z-5-FBR

6) Protective tube length SRO with Tr 18x4 screw

Without escape/ rotation protection	Escape/ rotation protection	Rotation protection, with limit switch set ES	Rotation protection with ES and KAR*
46+stroke	61+stroke	119+stroke	140+stroke

*Hinged bearing plate KAR, fitted on face F (below).

Standard ratios

Type	Version	Speed	Standard screw ²⁾	i	Stroke per drive shaft rotation ⁵⁾
Z-5-SN	Translating	Normal	Tr 18x4	4:1	1.00 mm
Z-5-SL	screw	Low		16:1	0.25 mm
Z-5-RN	Rotating	Normal	Tr 18x4	4:1	1.00 mm
Z-5-RL	screw	Low		16:1	0.25 mm

Screw jack mounting



Duty cycle thermal limit, for S+R

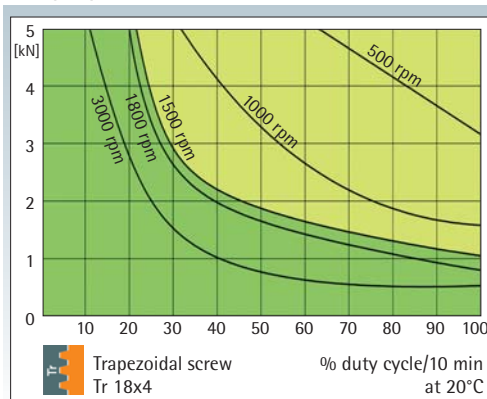

These curves are for guidance under standard industrial conditions (ambient temperature etc.) and correct maintenance (lubrication etc.). The max. input drive torques for optimum service life are at the right page - technical data (1500 rpm)

KGT: % duty cycle 2 times to 4 times higher

Trapezoidal screw

Tr



Z-5-R rotating screw 5 kN

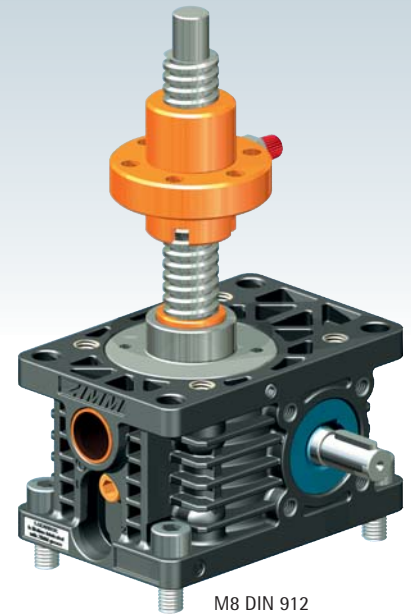
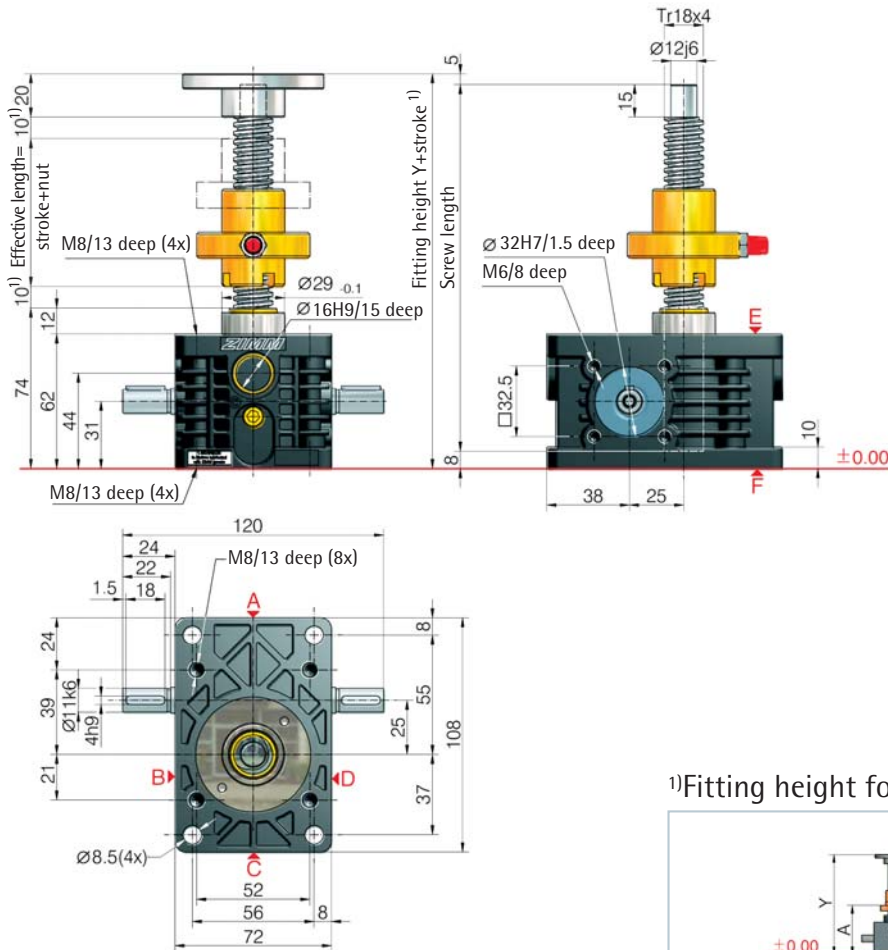

5

kN

¹⁾Fitting height for 0-stroke, with Tr 18x4 screw

All dimensions in mm	Flange nut FM	Duplex nut DM	Duplex nut DM with SIFA	Self-aligning nut PM	Greaseless nut FFDM
Bellows FB	Y/A	Y/A	Y/A	Y/A	Y/A
without bellows FB	149/96	159/109	184/134	192/141	167/117
2x Z-5-FB-265	-	207/132	229/154	240/164	215/140
2x Z-5-FB-500	-	337/197	359/219	370/229	345/205
2x Z-5-FB-800	-	377/217	399/239	410/249	385/225

Detailed instructions for determining the length can be found in Section 8

Technical data series Z-5-S / Z-5-R

max. compressive/tensile force, static	- 5 kN (0.5 t)
max. compressive/tensile force, dynamic	- see duty cycle curves
Nominal speed	- 1500 rpm
max. drive shaft speed	- 3000 rpm (depending on the load and duty cycle)
Screw size standard	- Tr 18x4 ²⁾
Gear ratio	- 4:1 (N) / 16:1 (L)
Housing material	- aluminium, corrosion-resistant
Worm shaft	- steel, case-hardened, ground
Weight of screw jack body	- 1.2 kg
Weight of screw/m	- 1.58 kg
Gearbox lubrication	- synthetic fluid grease
Screw lubrication	- grease lubrication
Gearbox operating temperature	- max. 60°C, higher on request
Moment of inertia	- N: 0.217 kg cm ² / L: 0.117 kg cm ²
Input torque (at 1500 rpm)	- max. 4.7 Nm (N) / max. 1.5 Nm (L)
Drive-through torque	- max. 39 Nm

Drive torque M_G (Nm)	- F (kN) \times 0.62 ³⁾⁵⁾ + M_L (N-normal) - F (kN) \times 0.21 ³⁾⁵⁾ + M_L (L-low)
Breakaway torque	- Drive torque $M_G \times 1.5$
Idling torque ⁴⁾ M_L (Nm)	- 0.10 (N-normal) / 0.08 (L-low speed)

Between gearbox and nut or nut and end of thread, provide for a safety distance of (minimum) 10 mm!

See Section 7 for the checklist.

Important information

- 1) - extension if a bellows or spiral spring is fitted: see the table or Section 8
- 2) - Tr 18x4 is standard, also available: double-pitch, stainless steel, left-handed, increased screw Tr 20x4 (only for the R version)
- 3) - factor includes efficiency, ratio and 30% safety
- 4) - at 20°C, can be higher when new
- 5) - for a 4 mm screw pitch



Z-10-S translating screw 10 kN

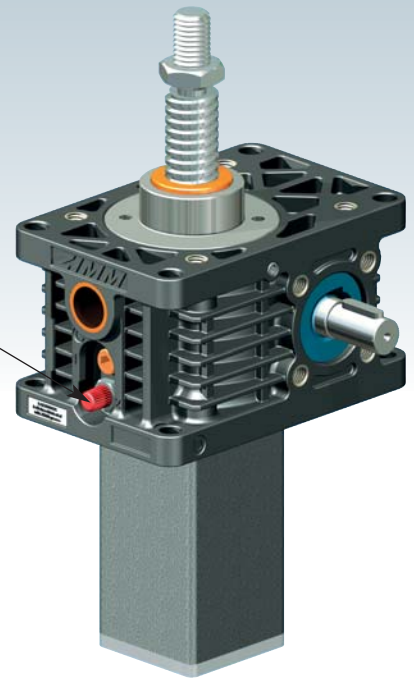

UNIQUE:
Screw lubrication
during operation

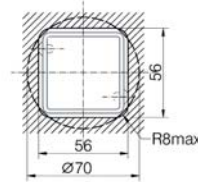
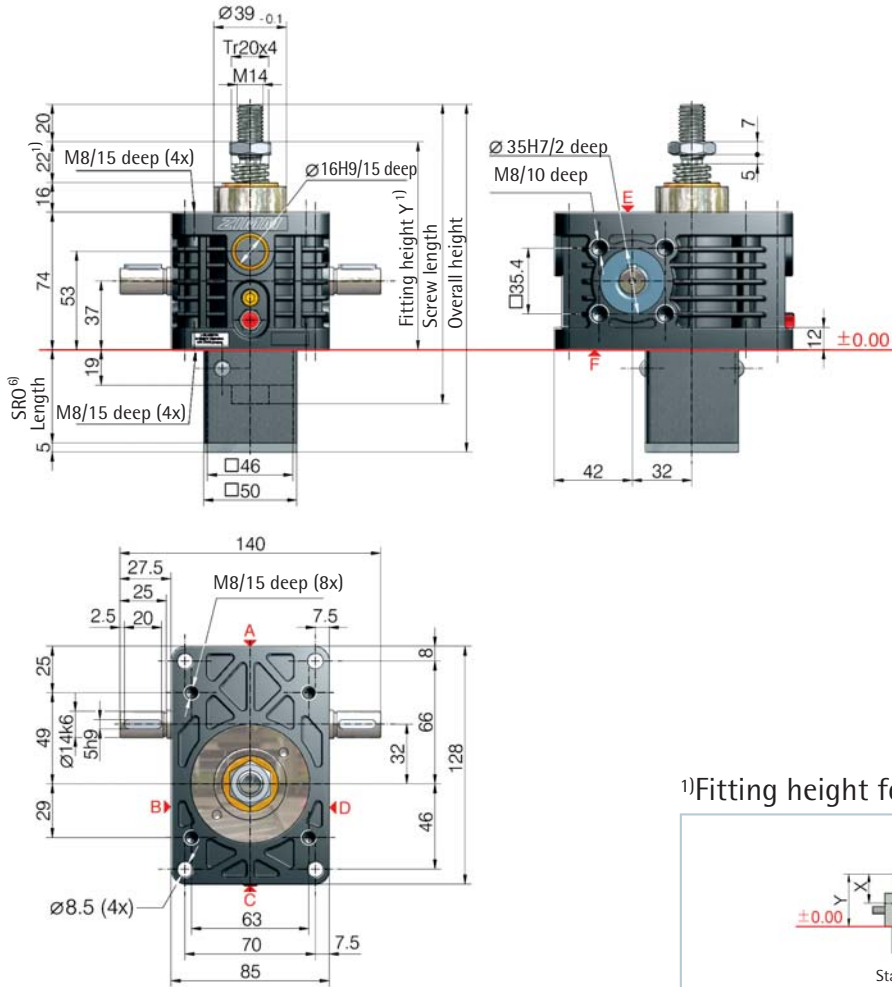

6) Protective tube length SRO with Tr 20x4 screw

Without escape/ rotation protection	Escape/ rotation protection	Rotation protection, with limit switch set ES	Rotation protection with ES and KAR*
49+stroke	69+stroke	121+stroke	141+stroke

*Hinged bearing plate KAR, fitted on face F (below).

1) Fitting height for 0-stroke, with Tr 20x4 screw

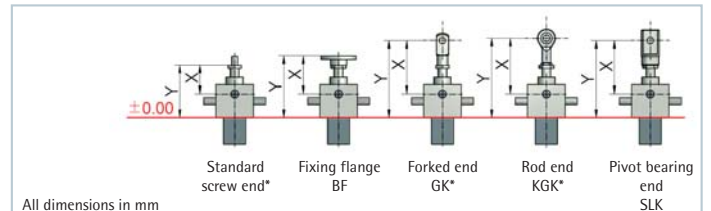

Bellocs FB	X/Y	X/Y	X/Y	X/Y	X/Y
without bellocs FB	59/112	80/133	115/168	120/173	115/168
Z-10-FB-340	140/193	136/189	196/249	201/254	171/224
Z-10-FB-700	160/213	156/209	216/269	221/274	191/244
Z-10-FB-1000	210/263	206/259	266/319	271/324	241/294

*with bellows fixing ring Z-10-FBR

Standard ratios

Type	Version	Speed	Standard screw ²⁾	i	Stroke per drive shaft rotation ⁵⁾
Z-10-SN	Translating	Normal	Tr 20x4	4:1	1.00 mm
Z-10-SL	screw	Low speed		16:1	0.25 mm
Z-10-RN	Rotating	Normal	Tr 20x4	4:1	1.00 mm
Z-10-RL	screw	Low speed		16:1	0.25 mm

Screw jack mounting



Duty cycle thermal limit, for S+R

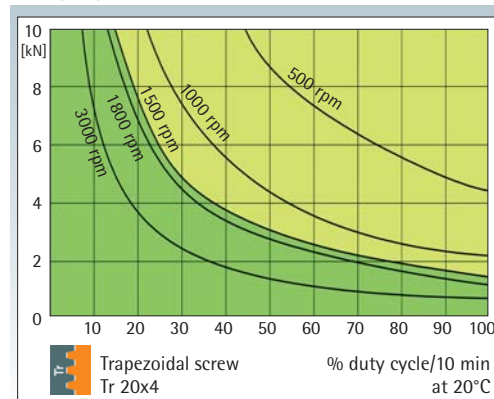

These curves are for guidance under standard industrial conditions (ambient temperature etc.) and correct maintenance (lubrication etc.). The max. input drive torques for optimum service life are at the right page - technical data (1500 rpm)

KGT: % duty cycle 2 times to 4 times higher

Trapezoidal screw

Tr



Z-10-R rotating screw 10 kN

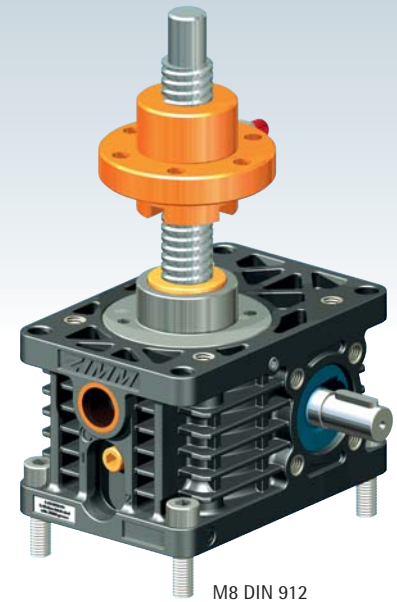
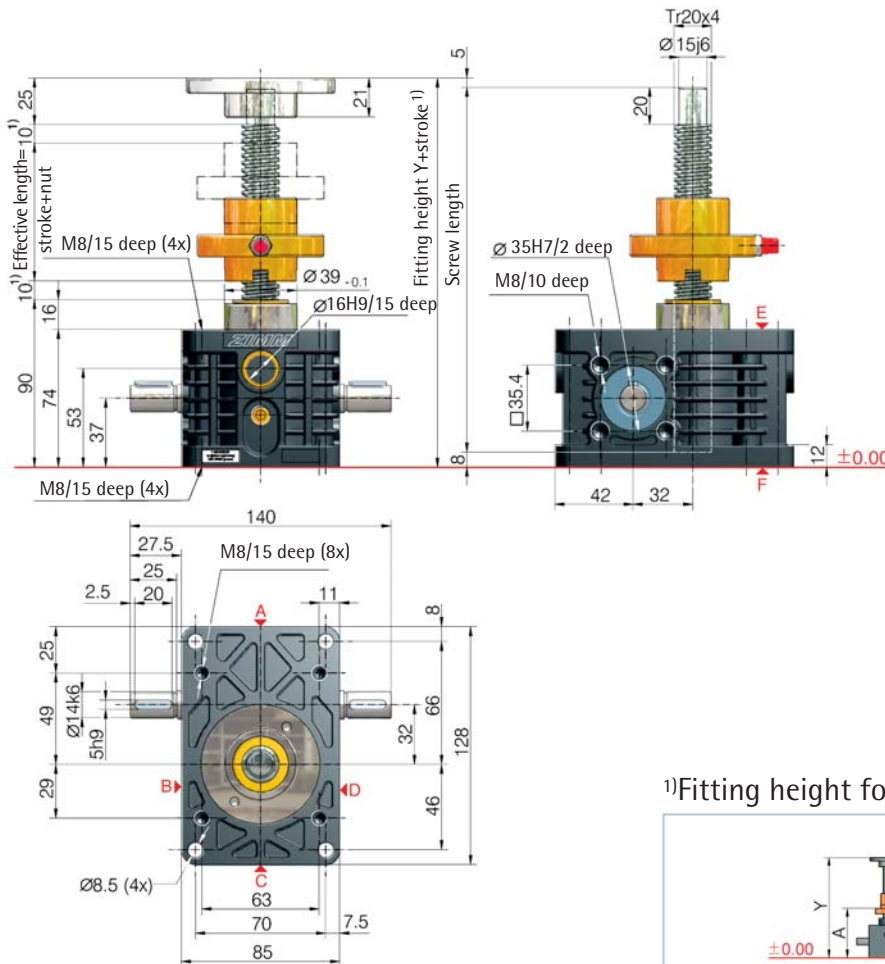

10

kN

¹⁾Fitting height for 0-stroke, with Tr 20x4 screw

All dimensions in mm	Flange nut FM	Duplex nut DM	Duplex nut DM with SIFA	Self-aligning nut PM	Greaseless nut FFDM
	Y/A	Y/A	Y/A	Y/A	Y/A
Bellocs FB	179/112	180/125	219/164	218/159	188/133
without bellocs FB	-	314/193	350/229	352/227	322/201
2x Z-10-FB-340	-	354/213	390/249	392/247	362/221
2x Z-10-FB-700	-	454/263	490/299	492/297	462/271

Detailed instructions for determining the length can be found in Section 8

Technical data series Z-10-S / Z-10-R

max. compressive/tensile force, static	- 10 kN (1 t)
max. compressive/tensile force, dynamic	- see duty cycle curves
Nominal speed	- 1500 rpm
max. drive shaft speed	- 3000 rpm (depending on the load and duty cycle)
Screw size standard	- Tr 20x4 ²⁾
Gear ratio	- 4:1 (N) / 16:1 (L)
Housing material	- aluminium, corrosion-resistant
Worm shaft	- steel, case-hardened, ground
Weight of screw jack body	- 2.1 kg
Weight of screw/m	- 2 kg
Gearbox lubrication	- synthetic fluid grease
Screw lubrication	- grease lubrication
Gearbox operating temperature	- max. 60°C, higher on request
Moment of inertia	- N: 0.641 kg cm ² / L: 0.271 kg cm ²
Input torque (at 1500 rpm)	- max. 13.5 Nm (N) / max. 7.5 Nm (L)
Drive-through torque	- max. 57 Nm

Drive torque M_G (Nm)	- F (kN) \times 0.64 ³⁾⁵⁾ + M_L (N-normal)
Breakaway torque	- F (kN) \times 0.20 ³⁾⁵⁾ + M_L (L-low speed)
Idling torque ⁴⁾ M_L (Nm)	- Drive torque $M_G \times 1.5$
	- 0.26 (N-normal) / 0.16 (L-low speed)

Between gearbox and nut or nut and end of thread, provide for a safety distance of (minimum) 10 mm!

See Section 7 for the checklist.

Important information

- 1) - extension if a bellows or spiral spring is fitted: see the table or Section 8
- 2) - Tr 20x4 is standard, also available: double-pitch, stainless steel, left-handed, increased screw Tr 30x6 (only for the R version)
- 3) - factor includes efficiency, ratio and 30% safety
- 4) - at 20°C, can be higher when new
- 5) - for a 4 mm screw pitch



Z-25-S translating screw 25 kN

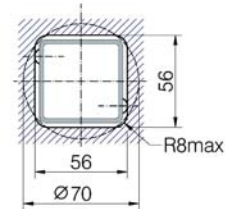
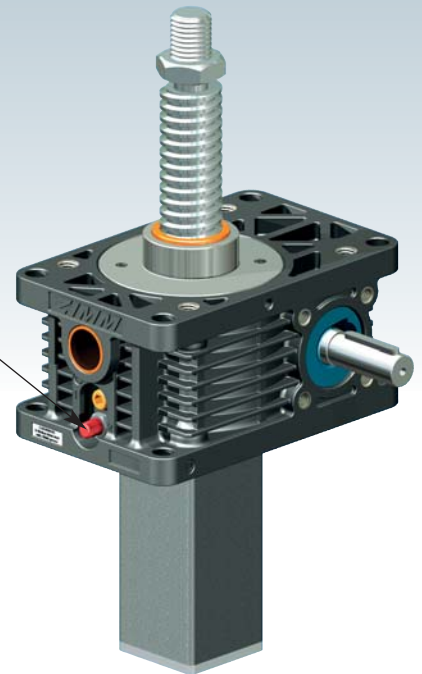
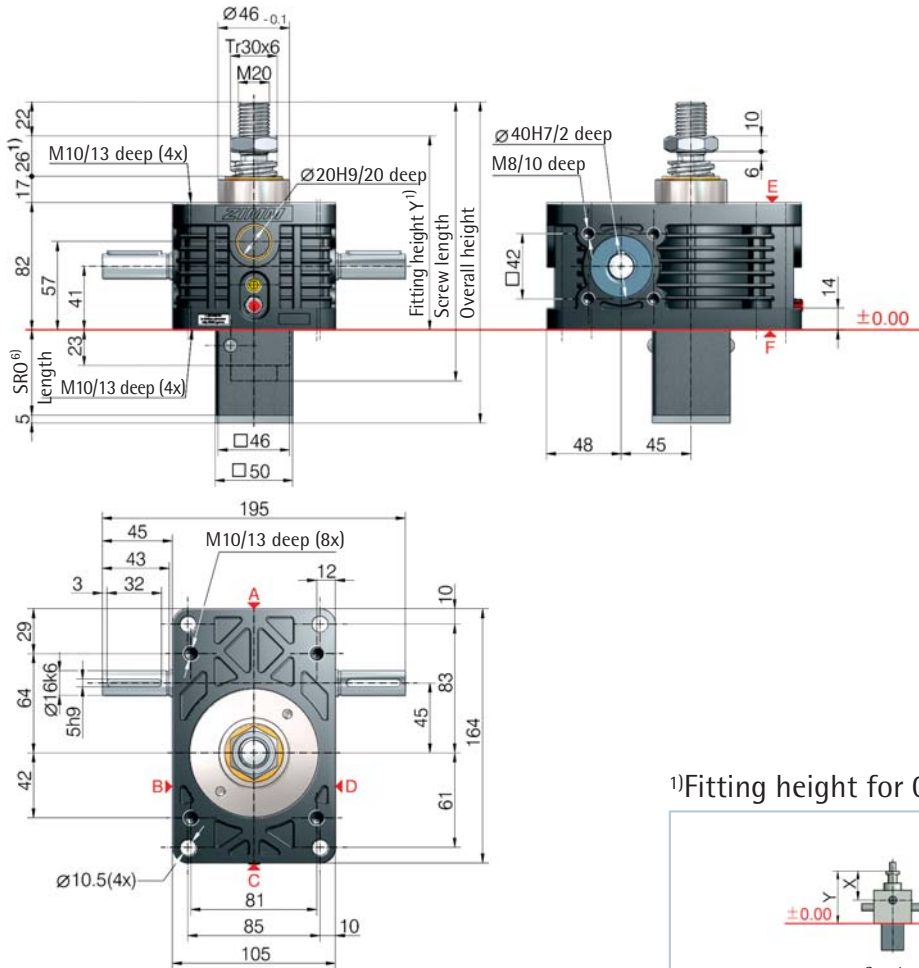

Opening for protective tube SRO square 56x56 or round Ø 70

1) Fitting height for 0-stroke, with Tr 30x6 screw

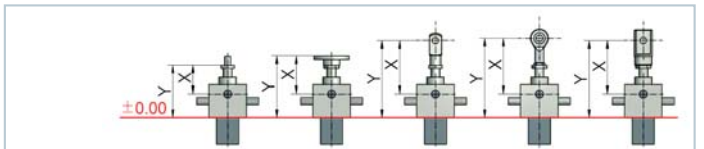

All dimensions in mm

Bellocs FB	X/Y	X/Y	X/Y	X/Y	X/Y
without bellocs FB	68/125	91/148	148/205	145/202	148/205
Z-25-FB-300	143/200	135/192	223/280	220/277	192/249
Z-25-FB-700	173/230	165/222	253/310	250/307	222/279
Z-25-FB-1000	193/250	185/242	273/330	270/327	242/299

*with bellows fixing ring Z-25-FBR

6) Protective tube length SRO with Tr 30x6 screw

Without escape/ rotation protection	Escape/ rotation protection	Rotation protection, with limit switch set ES	Rotation protection with ES and KAR*
53+stroke	73+stroke	125+stroke	149+stroke

*Hinged bearing plate KAR, fitted on face F (below).

Standard ratios

Type	Version	Speed	Standard screw ²⁾	i	Stroke per drive shaft rotation ⁵⁾
Z-25-SN	Translating	Normal	Tr 30x6	6:1	1.00 mm
Z-25-SL	screw	Low speed		24:1	0.25 mm
Z-25-RN	Rotating	Normal	Tr 30x6	6:1	1.00 mm
Z-25-RL	screw	Low speed		24:1	0.25 mm

Screw jack mounting



Duty cycle thermal limit, for S+R

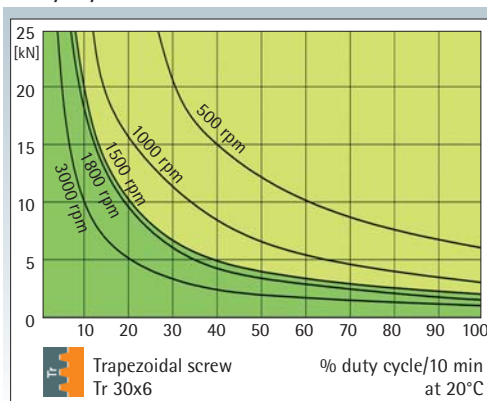

These curves are for guidance under standard industrial conditions (ambient temperature etc.) and correct maintenance (lubrication etc.). The max. input drive torques for optimum service life are at the right page - technical data (1500 rpm)

KGT: % duty cycle 2 times to 4 times higher

Trapezoidal screw

Tr



Z-25-R rotating screw 25 kN

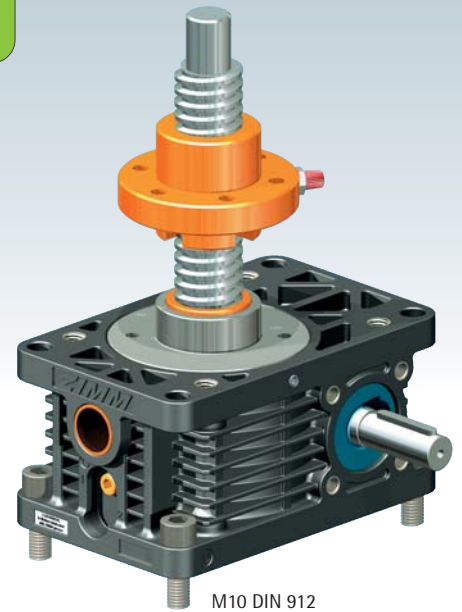

M10 DIN 912

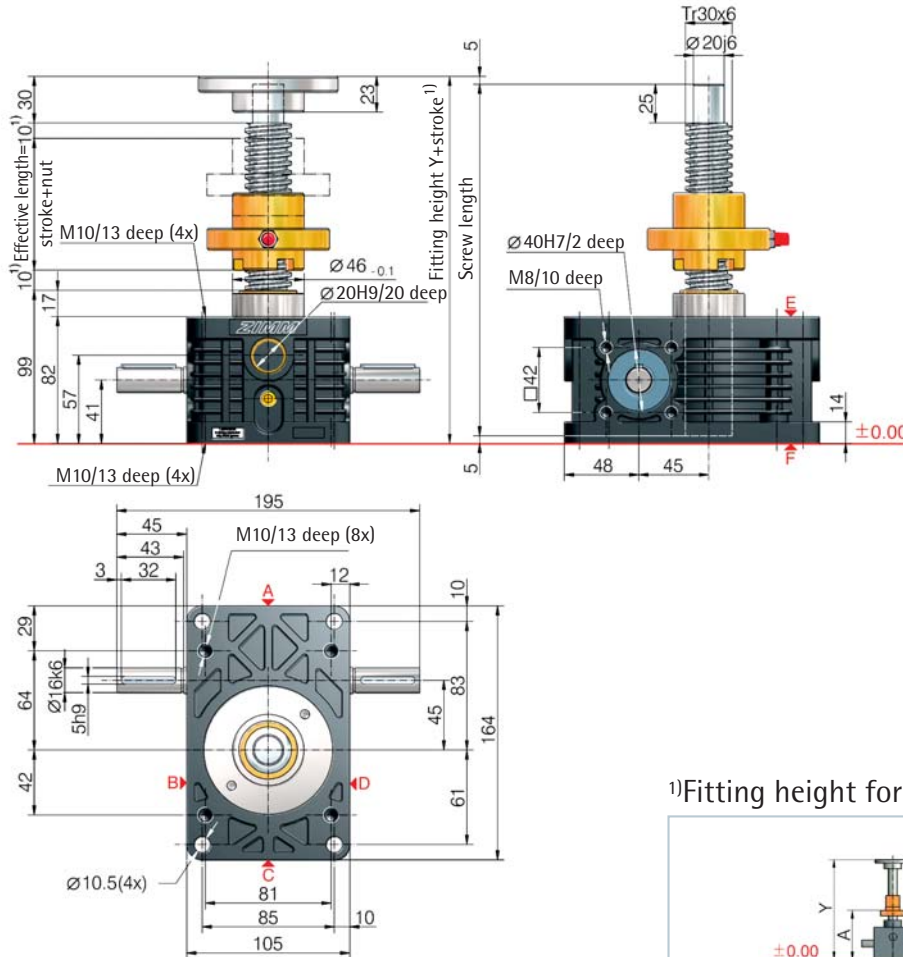

1) Fitting height for 0-stroke, with Tr 30x6 screw

All dimensions in mm	Flange nut FM	Duplex nut DM	Duplex nut DM with SIFA	Self-aligning nut PM	Greaseless nut FFDM
Bellows FB	Y/A	Y/A	Y/A	Y/A	Y/A
without bellows FB	195/123	199/136	244/181	244/177	208/145
2x Z-25-FB-300	-	314/196	353/235	359/237	325/207
2x Z-25-FB-700	-	374/226	413/265	419/267	385/237
2x Z-25-FB-1000	-	414/246	453/285	459/287	425/257

Detailed instructions for determining the length can be found in Section 8

25

kN

Technical data series Z-25-S / Z-25-R

max. compressive/tensile force, static	- 25 kN (2.5 t)
max. compressive/tensile force, dynamic	- see duty cycle curves
Nominal speed	- 1500 rpm
max. drive shaft speed	- 3000 rpm (depending on the load and duty cycle)
Screw size standard	- Tr 30x6 ²⁾
Gear ratio	- 6:1 (N) / 24:1 (L)
Housing material	- aluminium, corrosion-resistant
Worm shaft	- steel, case-hardened, ground
Weight of screw jack body	- 3.8 kg
Weight of screw/m	- 4.5 kg
Gearbox lubrication	- synthetic fluid grease
Screw lubrication	- grease lubrication
Gearbox operating temperature	- max. 60°C, higher on request
Moment of inertia	- N: 1.449 kg cm ² / L: 0.589 kg cm ²
Input torque (at 1500 rpm)	- max. 18 Nm (N) / max. 10 Nm (L)
Drive-through torque	- max. 108 Nm

Drive torque M_G (Nm)	- F (kN) \times 0.63 ³⁾ + M_L (N-normal)
Breakaway torque	- F (kN) \times 0.20 ³⁾ + M_L (L-low speed)
Idling torque ⁴⁾ M_L (Nm)	- Drive torque M_G \times 1.5
	- 0.36 (N-normal) / 0.26 (L-low speed)

Between gearbox and nut or nut and end of thread, provide for a safety distance of (minimum) 10 mm!

See Section 7 for the checklist.

Important information

- 1) - extension if a bellows or spiral spring is fitted: see the table or Section 8
- 2) - Tr 30x6 is standard, also available: double-pitch, stainless steel, left-handed, increased screw Tr 40x7 (only for the R version)
- 3) - factor includes efficiency, ratio and 30% safety
- 4) - at 20°C, can be higher when new
- 5) - for a 6 mm screw pitch



UNIQUE:
Screw lubrication
during operation

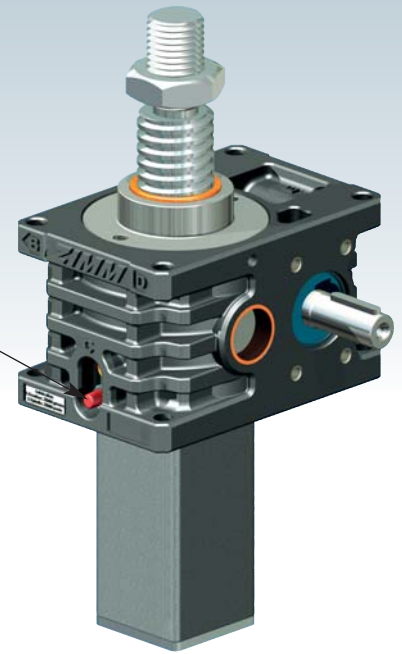

Z-35-S translating screw 35 kN

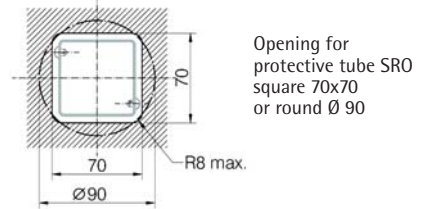
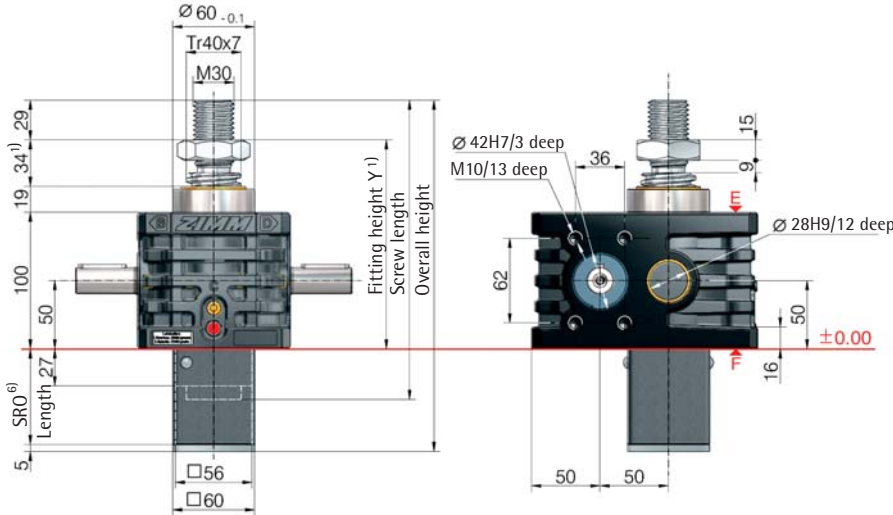

Opening for protective tube SRO
square 70x70
or round Ø 90

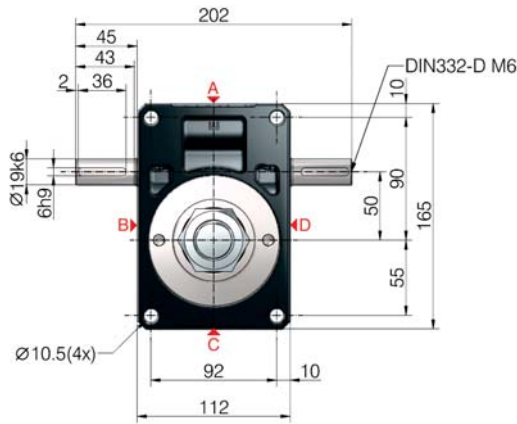

1) Fitting height for 0-stroke, with Tr 40x7 screw

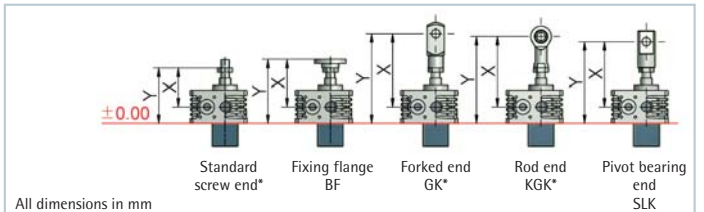

All dimensions in mm

Bellocs FB	X/Y	X/Y	X/Y	X/Y	X/Y
without bellocs FB	103/153	133/183	223/273	213/263	195/245
Z-50-FB-390	198/248	182/232	318/368	308/358	244/294
Z-50-FB-600	185/235	169/219	305/355	295/345	231/281
Z-50-FB-1000	243/293	227/277	363/413	353/403	289/339
Z-50-FB-1200	238/288	222/272	358/408	348/398	284/334
Z-50-FB-1500	293/343	277/327	413/463	403/453	339/389

*with bellows fixing ring Z-50-FBR

6) Protective tube length SRO with Tr 40x7 screw

Without escape/rotation protection	Escape/rotation protection	Rotation protection, with limit switch set ES
57+stroke	87+stroke	143+stroke

Standard ratios

Type	Version	Speed	Standard screw ²⁾	i	Stroke per drive shaft rotation ⁵⁾
Z-35-SN	Translating	Normal	Tr 40x7	7:1	1.00 mm
Z-35-SL	screw	Low speed		28:1	0.25 mm
Z-35-RN	Rotating	Normal	Tr 40x7	7:1	1.00 mm
Z-35-RL	screw	Low speed		28:1	0.25 mm

Screw jack mounting



Duty cycle thermal limit, for S+R

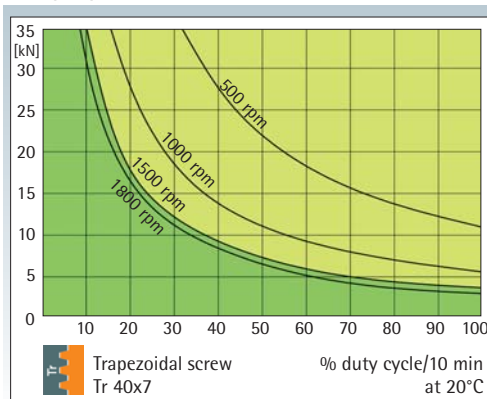

These curves are for guidance under standard industrial conditions (ambient temperature etc.) and correct maintenance (lubrication etc.). The max. input drive torques for optimum service life are at the right page - technical data (1500 rpm)

KGT:
% duty cycle
2 times to
4 times higher

Trapezoidal screw

Tr



Z-35-R rotating screw 35 kN

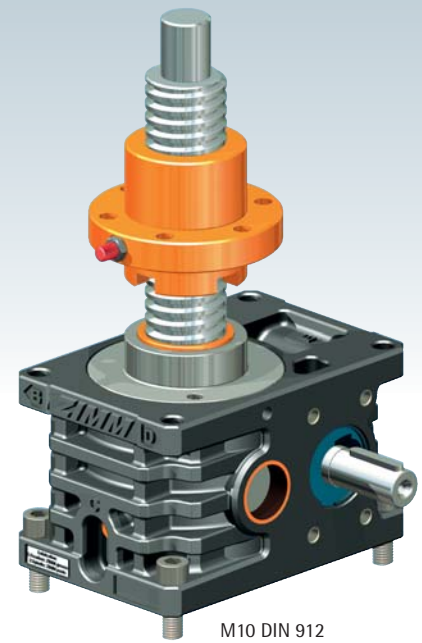
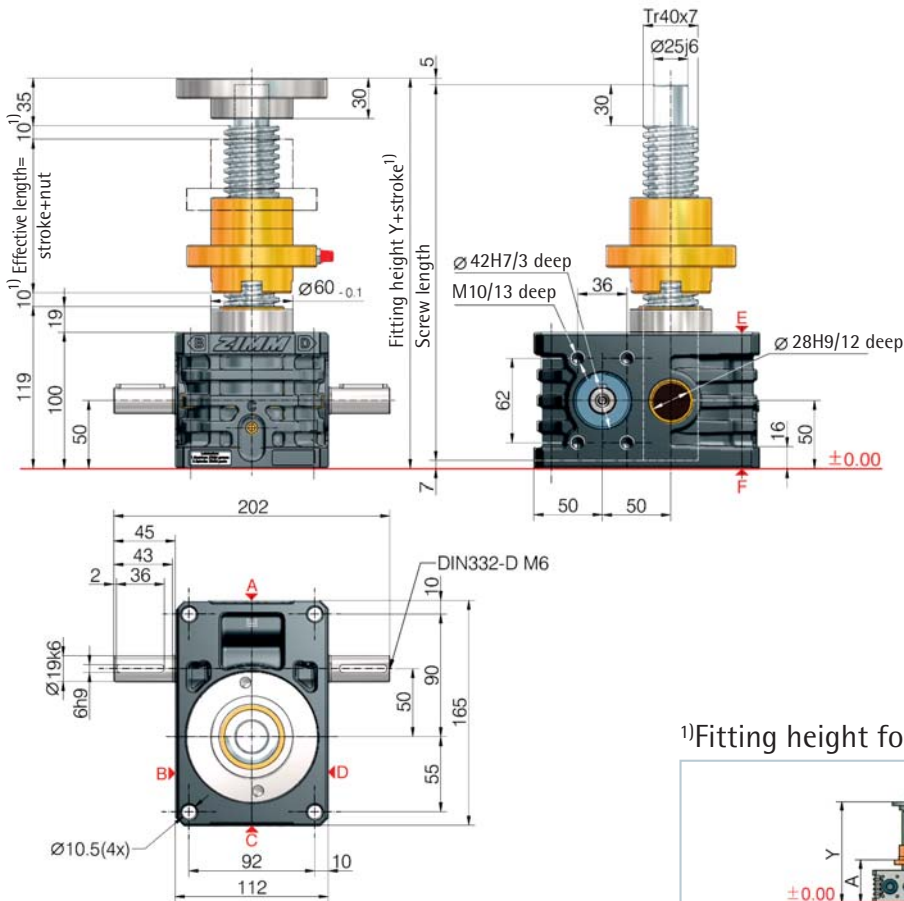

M10 DIN 912

1) Fitting height for 0-stroke, with Tr 40x7 screw

All dimensions in mm	Flange nut FM	Duplex nut DM	Duplex nut DM with SIFA	Self-aligning nut PM	Greaseless nut FFDM
Bellows FB	Y/A	Y/A	Y/A	Y/A	Y/A
without bellows FB	240/145	244/163	307/226	303/228	259/179
2x Z-50-FB-390	-	387/236	446/295	446/301	404/254
2x Z-50-FB-600	-	361/223	420/282	420/288	378/241
2x Z-50-FB-1000	-	477/281	536/340	536/346	494/299
2x Z-50-FB-1200	-	467/276	526/335	526/341	484/294
2x Z-50-FB-1500	-	577/331	636/390	636/396	594/349

Detailed instructions for determining the length can be found in Section 8

35

kN

Technical data series Z-35-S / Z-35-R

max. compressive/tensile force, static	- 35 kN (3.5 t)
max. compressive/tensile force, dynamic	- see duty cycle curves
Nominal speed	- 1500 rpm
max. drive shaft speed	- 1800 rpm
Screw size standard	- Tr 40x7 ²⁾
Gear ratio	- 7:1 (N) / 28:1 (L)
Housing material	- GGG-50, corrosion-resistant
Worm shaft	- steel, case-hardened, ground
Weight of screw jack body	- 9.5 kg
Weight of screw/m	- 8 kg
Gearbox lubrication	- synthetic fluid grease
Screw lubrication	- grease lubrication
Gearbox operating temperature	- max. 60°C, higher on request
Moment of inertia	- N: 2.18 kg cm ² / L: 0.90 kg cm ²
Input torque (at 1500 rpm)	- max. 19.8 Nm (N) / max. 9 Nm (L)
Drive-through torque	- max. 130 Nm

Drive torque M_G (Nm)	- F (kN) \times 0.69 ³⁾⁵⁾ + M_L (N-normal) - F (kN) \times 0.23 ³⁾⁵⁾ + M_L (L-low speed)
Breakaway torque	- Drive torque M_G \times 1.5
Idling torque ⁴⁾ M_L (Nm)	- 0.56 (N-normal) / 0.40 (L-low speed)

Between gearbox and nut or nut and end of thread, provide for a safety distance of (minimum) 10 mm!

See Section 7 for the checklist.

Important information

- extension if a bellows or spiral spring is fitted: see the table or Section 8
- Tr 40x7 is standard, also available: double-pitch, stainless steel, left-handed, increased screw Tr 55x9 (only for the R version)
- factor includes efficiency, ratio and 30% safety
- at 20°C, can be higher when new
- for a 7 mm screw pitch



UNIQUE:
Screw lubrication
during operation

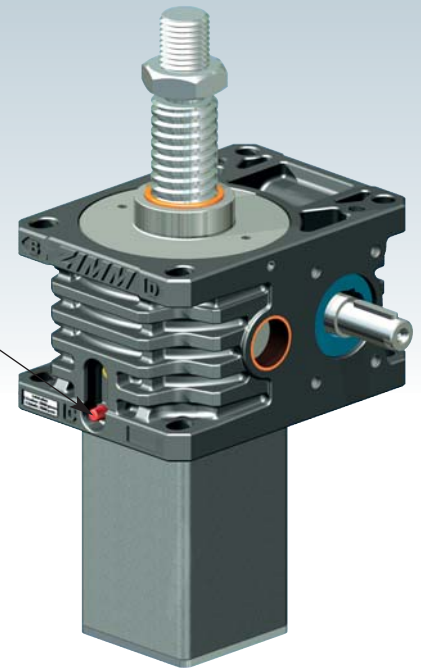

Z-50-S translating screw 50 kN

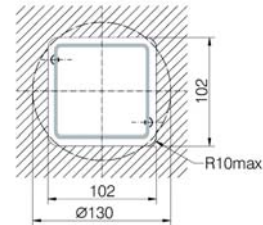
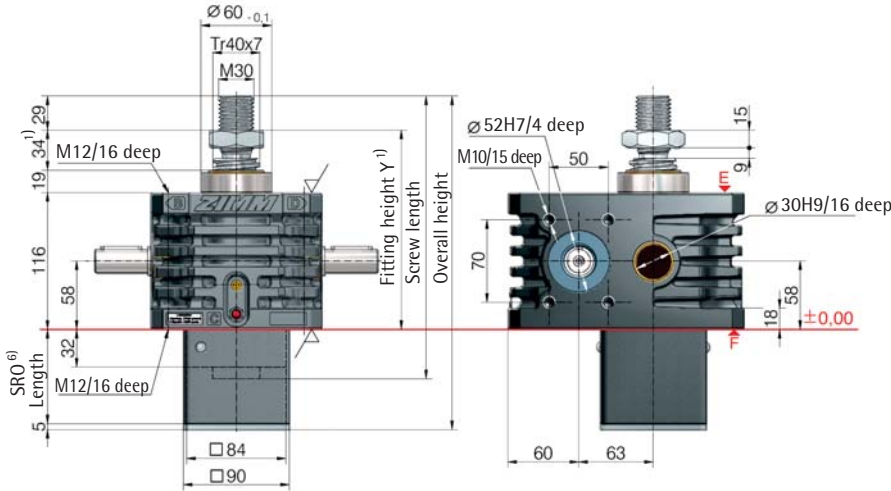

Opening for
protective tube SRO
square 102x102
or round Ø 130

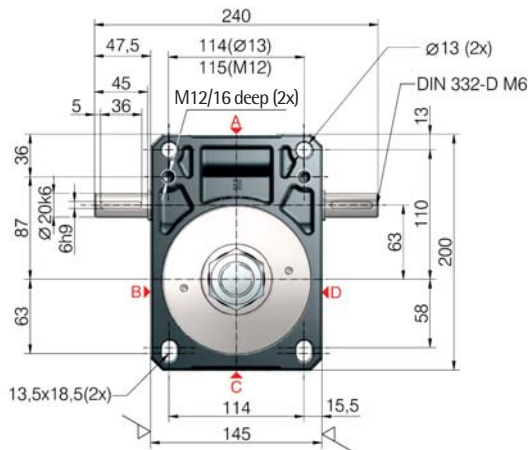

¹⁾Fitting height for 0-stroke, with Tr 40x7 screw

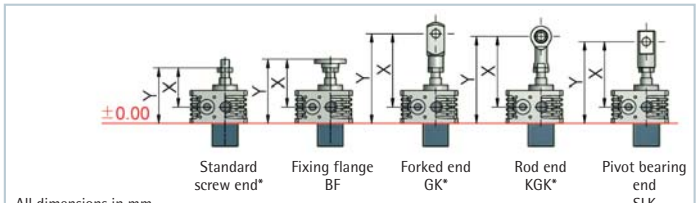

All dimensions in mm

Bellocs FB	X/Y	X/Y	X/Y	X/Y	X/Y
without bellocs FB	111/169	141/199	231/289	221/279	203/261
Z-50-FB-390	206/264	190/248	326/384	316/374	252/310
Z-50-FB-600	193/251	177/235	313/371	303/361	239/297
Z-50-FB-1000	251/309	235/293	371/429	361/419	297/355
Z-50-FB-1200	246/304	230/288	366/424	356/414	292/350
Z-50-FB-1500	301/359	285/343	421/479	411/469	347/405

*with bellocs fixing ring Z-50-FBR

⁶⁾Protective tube length SRO with Tr 40x7 screw

Without escape/rotation protection	Escape/rotation protection	Rotation protection, with limit switch set ES
62+stroke	92+stroke	144+stroke

Standard ratios

Type	Version	Speed	Standard screw ²⁾	i	Stroke per drive shaft rotation ⁵⁾
Z-50-SN	Translating	Normal	Tr 40x7	7:1	1.00 mm
Z-50-SL	screw	Low speed		28:1	0.25 mm
Z-50-RN	Rotating	Normal	Tr 40x7	7:1	1.00 mm
Z-50-RL	screw	Low speed		28:1	0.25 mm

Screw jack mounting



Duty cycle thermal limit, for S+R

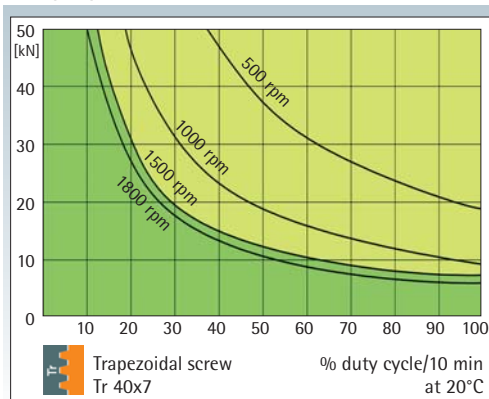

These curves are for guidance under standard industrial conditions (ambient temperature etc.) and correct maintenance (lubrication etc.). The max. input drive torques for optimum service life are at the right page - technical data (1500 rpm)

KGK:
% duty cycle
2 times to
4 times higher

Trapezoidal screw

Tr



Z-50-R rotating screw 50 kN

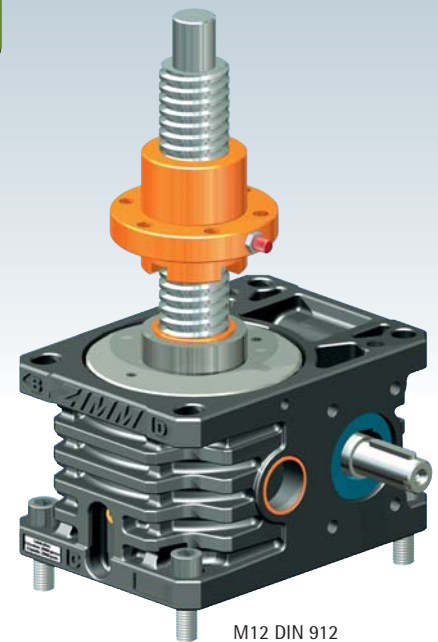
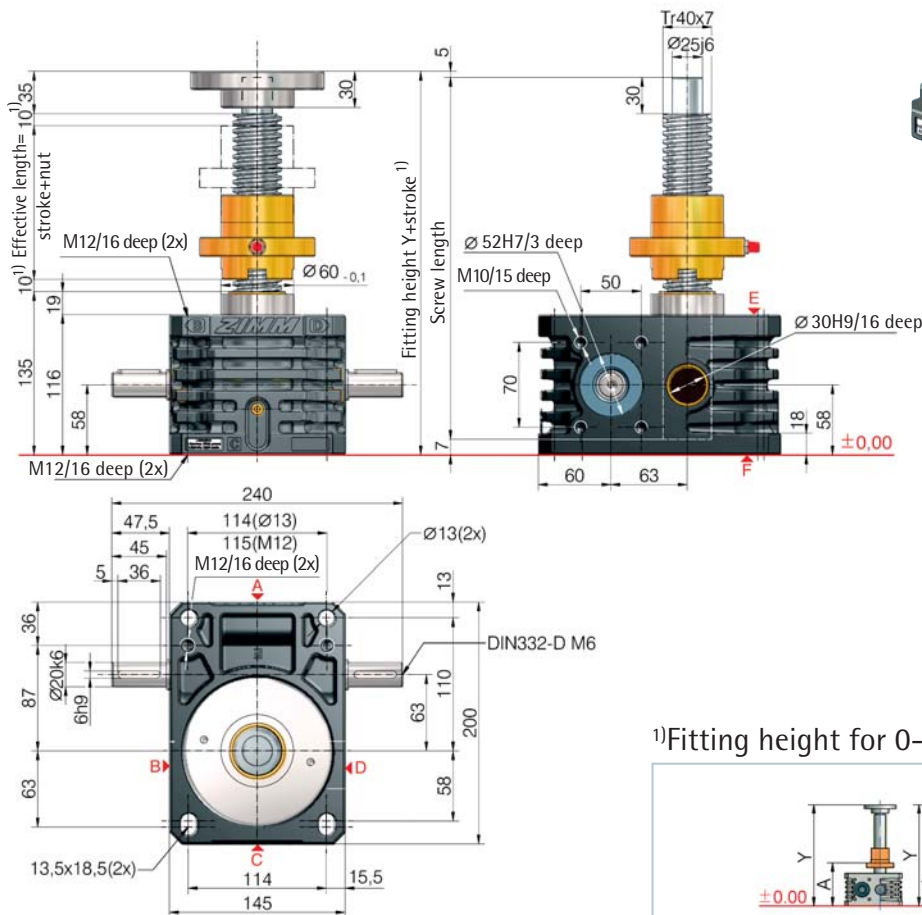

$1^{)}$ Fitting height for 0-stroke, with Tr 40x7 screw

All dimensions in mm	Flange nut FM	Duplex nut DM	Duplex nut DM with SIFA	Self-aligning nut PM	Greaseless nut FFDM
Bellows FB	Y/A	Y/A	Y/A	Y/A	Y/A
without bellows FB	256/161	260/179	323/242	319/244	275/195
2x Z-50-FB-390	-	403/252	462/311	462/317	420/270
2x Z-50-FB-600	-	377/239	436/298	436/304	394/257
2x Z-50-FB-1000	-	493/297	552/356	552/362	510/315
2x Z-50-FB-1200	-	483/292	542/351	542/357	500/310
2x Z-50-FB-1500	-	593/347	652/406	652/412	610/365

Detailed instructions for determining the length can be found in Section 8

50 kN

Technical data series Z-50-S / Z-50-R

max. compressive/tensile force, static	- 50 kN (5 t)
max. compressive/tensile force, dynamic	- see duty cycle curves
Nominal speed	- 1500 rpm
max. drive shaft speed	- 1800 rpm
Screw size standard	- Tr 40x7 ²⁾
Gear ratio	- 7:1 (N) / 28:1 (L)
Housing material	- GGG-50, corrosion-resistant
Worm shaft	- steel, case-hardened, ground
Weight of screw jack body	- 17 kg
Weight of screw/m	- 8 kg
Gearbox lubrication	- synthetic fluid grease
Screw lubrication	- grease lubrication
Gearbox operating temperature	- max. 60°C, higher on request
Moment of inertia	- N: 6.40 kg cm ² / L: 2.53 kg cm ²
Input torque (at 1500 rpm)	- max. 31.5 Nm (N) / max. 10.4 Nm (L)
Drive-through torque	- max. 260 Nm

Drive torque M_G (Nm)	- F (kN) \times 0.68 ³⁾⁵⁾ + M_L (N-normal) - F (kN) \times 0.23 ³⁾⁵⁾ + M_L (L-low speed)
Breakaway torque	- Drive torque $M_G \times 1.5$
Idling torque ⁴⁾ M_L (Nm)	- 0.76 (N-normal) / 0.54 (L-low speed)

Between gearbox and nut or nut and end of thread, provide for a safety distance of (minimum) 10 mm!

See Section 7 for the checklist.

Important information

- extension if a bellows or spiral spring is fitted: see the table or Section 8
- Tr 40x7 is standard, also available: double-pitch, stainless steel, left-handed, increased screw Tr 55x9 (only for the R version)
- factor includes efficiency, ratio and 30% safety
- at 20°C, can be higher when new
- for a 7 mm screw pitch



Z-50/Tr50-S translating screw 50 kN

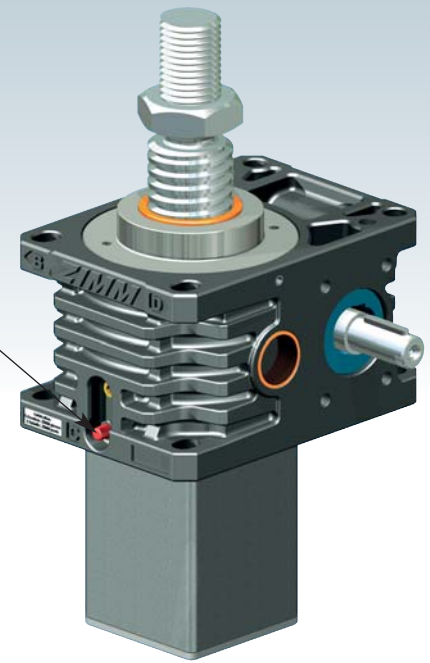

UNIQUE:
Screw lubrication
during operation

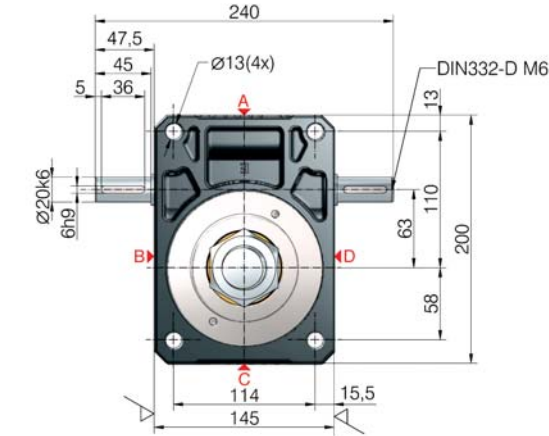
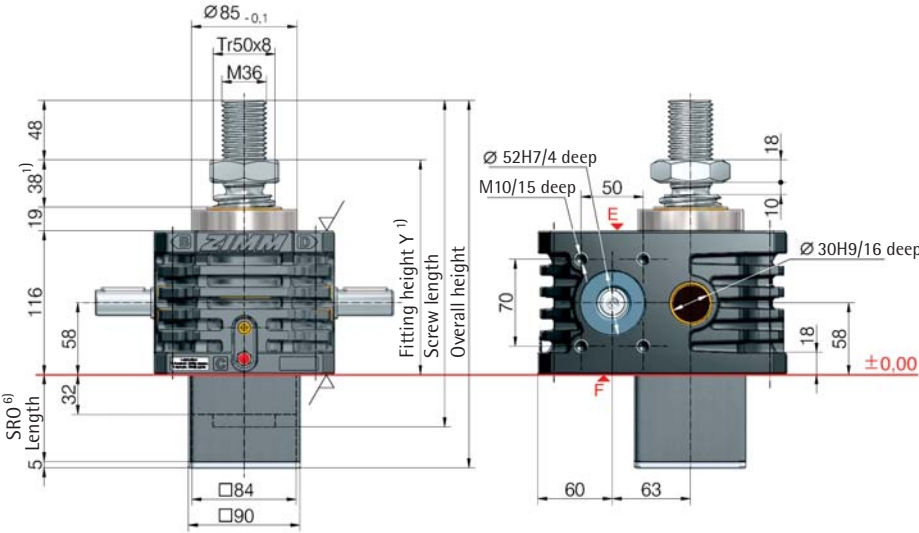

i For Z-50/Tr50, use screw-related accessories from the Z-100.

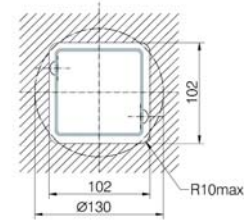

Opening for protective tube SRO
square 102x102
or round Ø 130

¹⁾Fitting height for 0-stroke, with Tr 50x8 screw

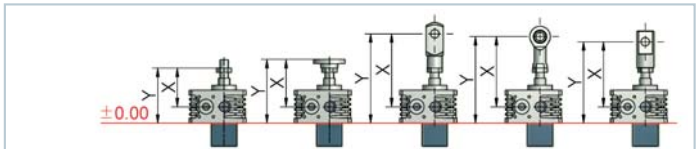

All dimensions in mm

Bellocs FB	X/Y	X/Y	X/Y	X/Y	X/Y
without bellocs FB	115/173	165/223	259/317	257/315	223/281
Z-100-FB-285	198/256	200/258	342/400	340/398	258/316
Z-100-FB-600	195/253	197/255	339/397	337/395	255/313
Z-100-FB-1000	253/311	255/313	397/455	395/453	313/371
Z-100-FB-1500	303/361	305/363	447/505	445/503	363/421

*with bellows fixing ring Z-100-FBR

⁶⁾Protective tube length SRO with Tr 50x8 screw

Without escape/rotation protection	Escape/rotation protection	Rotation protection, with limit switch set ES
62+stroke	92+stroke	144+stroke

Standard ratios

Type	Version	Speed	Standard screw ²⁾	i	Stroke per drive shaft rotation ⁵⁾
Z-50/Tr50-SN	Translating	Normal	Tr 50x8	7:1	1.143 mm
Z-50/Tr50-SL	screw	Low speed		28:1	0.286 mm

Screw jack mounting



Duty cycle thermal limit, for S

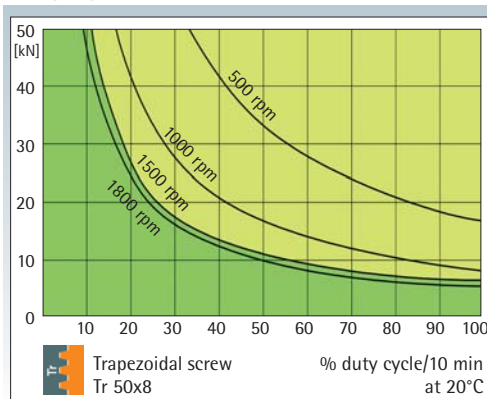

These curves are for guidance under standard industrial conditions (ambient temperature etc.) and correct maintenance (lubrication etc.). The max. input drive torques for optimum service life are at the right page - technical data (1500 rpm)

KGT:
% duty cycle
2 times to
4 times higher

Z-35 + Z-50/Tr50 heavy duty screws for long strokes

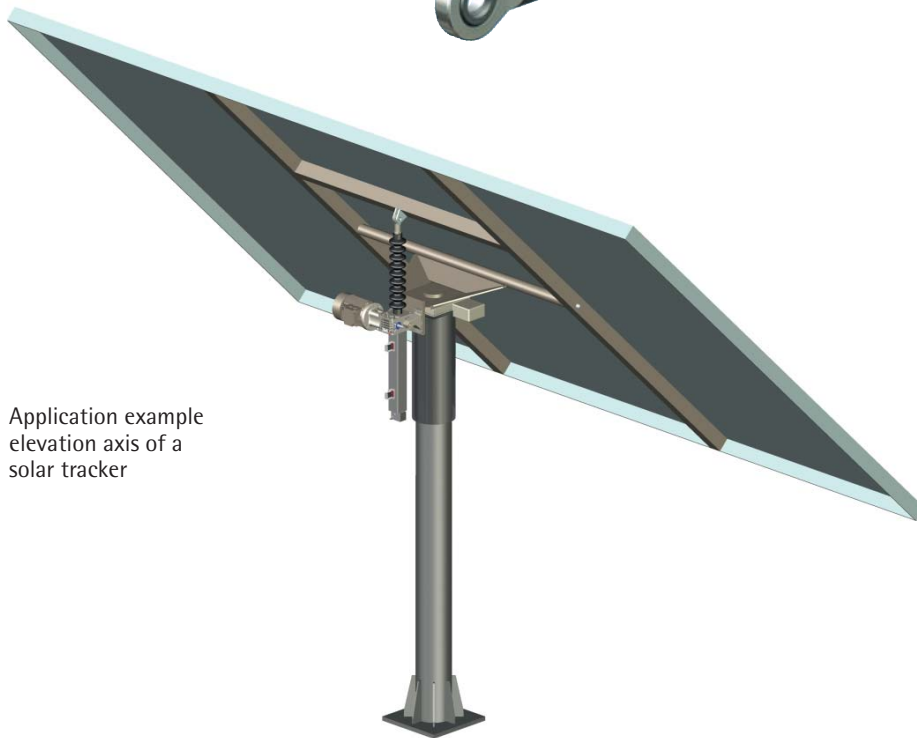
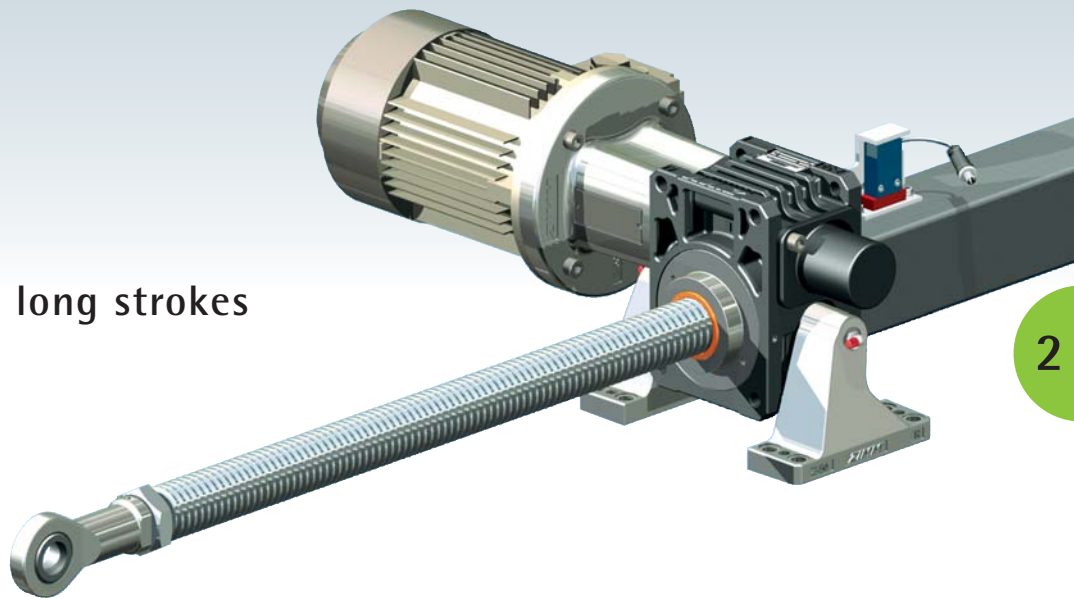

Application example
elevation axis of a
solar tracker

Heavy duty screws

The screw diameter is a critical factor in long-stroke applications. Long-stroke screws have to be oversized to prevent buckling and other problems. However, increasing the diameter of the screw means that the gearbox also has to be oversized accordingly.

To overcome this problem, the Z-35 and the Z-50/Tr50 are specially designed with stronger screws to prevent buckling on applications with long strokes. The screw does not therefore require oversizing and consequently a compact gearbox can also be used on long-stroke applications.

Z-35: with Tr 40x7 screw
Z-50/Tr50: with Tr 50x8 screw

50

kN

Technical data series Z-50/Tr50-S

max. compressive/tensile force, static	- 50 kN (5 t)
max. compressive/tensile force, dynamic	- see duty cycle curves
Nominal speed	- 1500 rpm
max. drive shaft speed	- 1800 rpm
Screw size standard	- Tr 50x8 ²⁾
Gear ratio	- 7:1 (N) / 28:1 (L)
Housing material	- GGG-50, corrosion-resistant
Worm shaft	- steel, case-hardened, ground
Weight of screw jack body	- 17 kg
Weight of screw/m	- 13 kg
Gearbox lubrication	- synthetic fluid grease
Screw lubrication	- grease lubrication
Gearbox operating temperature	- max. 60°C, higher on request
Moment of inertia	- N: 6.65 kg cm ² / L: 2.62 kg cm ²
Input torque (at 1500 rpm)	- max. 31.5 Nm (N) / max. 10.4 Nm (L)
Drive-through torque	- max. 260 Nm

Drive torque M_G (Nm)	- F (kN) \times 0.86 ³⁾⁵⁾ + M_L (N-normal)
Breakaway torque	- F (kN) \times 0.29 ³⁾⁵⁾ + M_L (L-low speed)
Idling torque ⁴⁾ M_L (Nm)	- Drive torque M_G \times 1.5
	- 0.76 (N-normal) / 0.54 (L-low speed)

Between gearbox and nut or nut and end of thread, provide for a safety distance of (minimum) 10 mm!
See Section 7 for the checklist.

Important information

- 1) - extension if a bellows or spiral spring is fitted: see the table or Section 8
- 2) - Tr 50x8 is standard, also available: double-pitch, stainless steel, left-handed
- 3) - factor includes efficiency, ratio and 30% safety
- 4) - at 20°C, can be higher when new
- 5) - for a 8 mm screw pitch



Z-100-S translating screw 100 kN

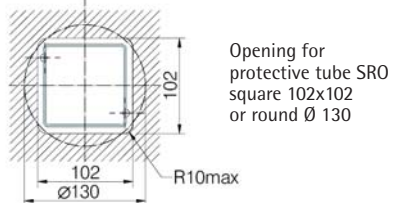
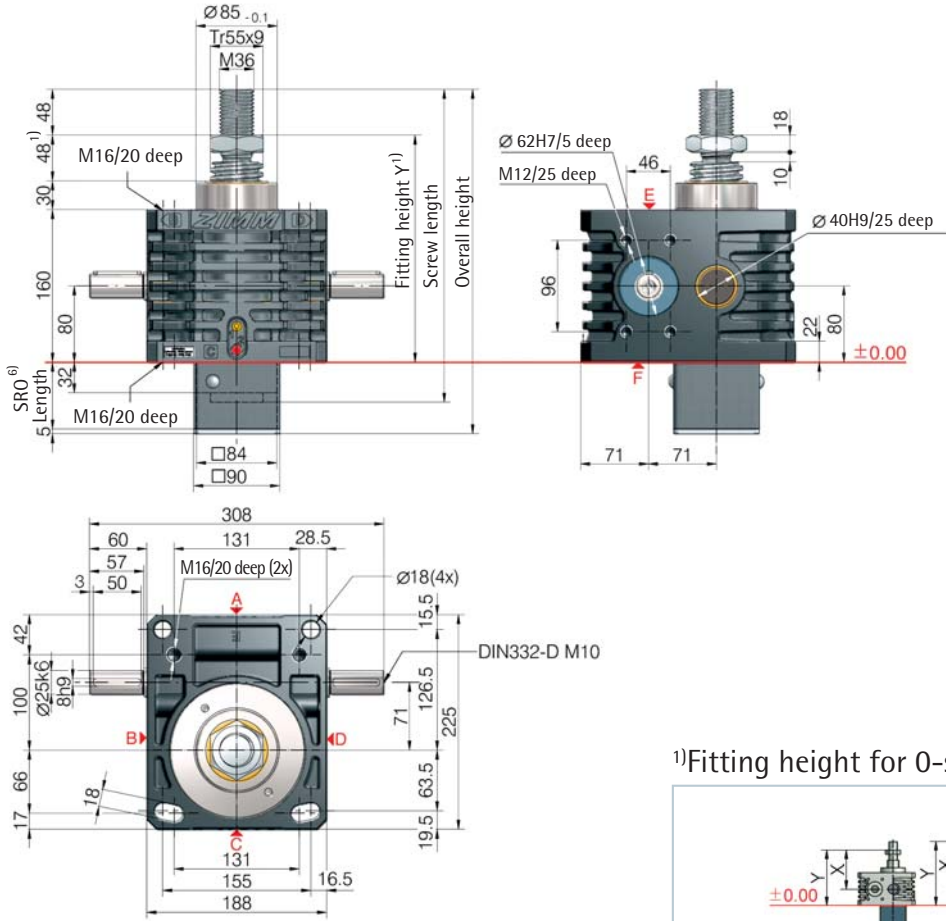
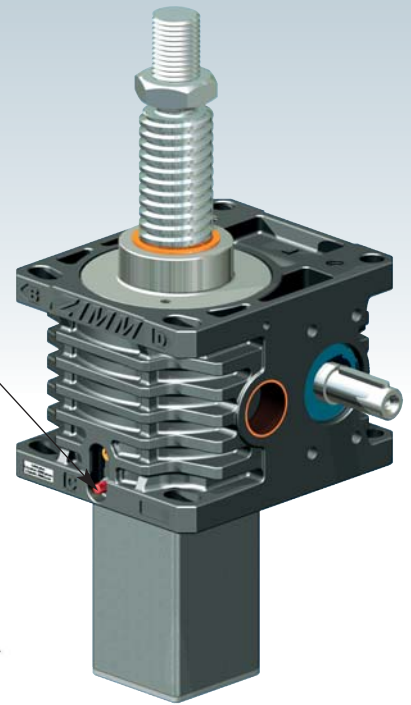

6) Protective tube length SRO with Tr 55x9 screw

Without escape/rotation protection	Escape/rotation protection	Rotation protection, with limit switch set ES
82+stroke	112+stroke	144+stroke

1) Fitting height for 0-stroke, with Tr 55x9 screw

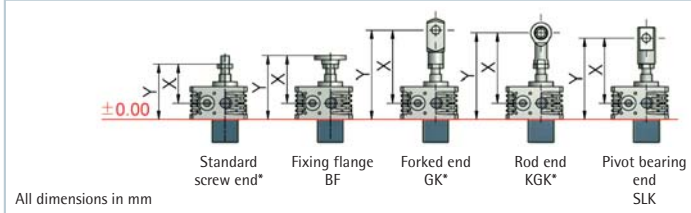

Bellocs FB	X/Y	X/Y	X/Y	X/Y	X/Y
without bellocs FB	158/238	208/288	302/382	300/380	266/346
Z-100-FB-285	231/311	233/313	375/455	373/453	291/371
Z-100-FB-600	228/308	230/310	372/452	370/450	288/368
Z-100-FB-1000	286/366	288/368	430/510	428/508	346/426
Z-100-FB-1500	336/416	338/418	480/560	478/558	396/476

*with bellows fixing ring Z-100-FBR

Standard ratios

Type	Version	Speed	Standard screw ²⁾	i	Stroke per drive shaft rotation ⁵⁾
Z-100-SN	Translating	Normal	Tr 55x9	9:1	1.00 mm
Z-100-SL	screw	Low speed		36:1	0.25 mm
Z-100-RN	Rotating	Normal	Tr 55x9	9:1	1.00 mm
Z-100-RL	screw	Low speed		36:1	0.25 mm

Screw jack mounting



Duty cycle thermal limit, for S+R

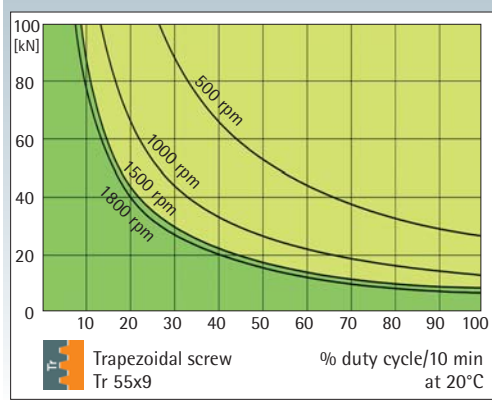

These curves are for guidance under standard industrial conditions (ambient temperature etc.) and correct maintenance (lubrication etc.). The max. input drive torques for optimum service life are at the right page - technical data (1500 rpm)

KGT: % duty cycle 2 times to 4 times higher



Z-100-R rotating screw 100 kN

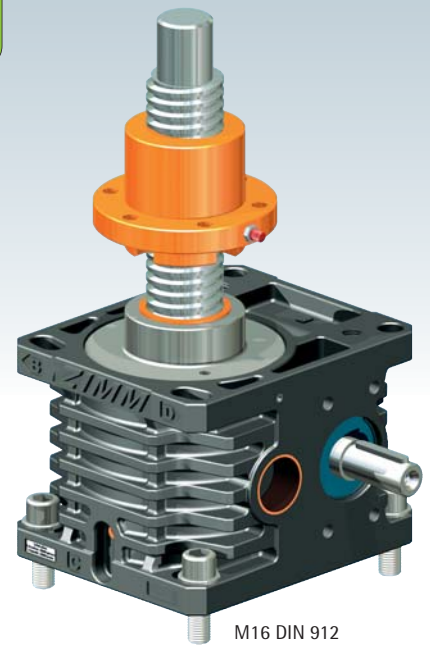

M16 DIN 912

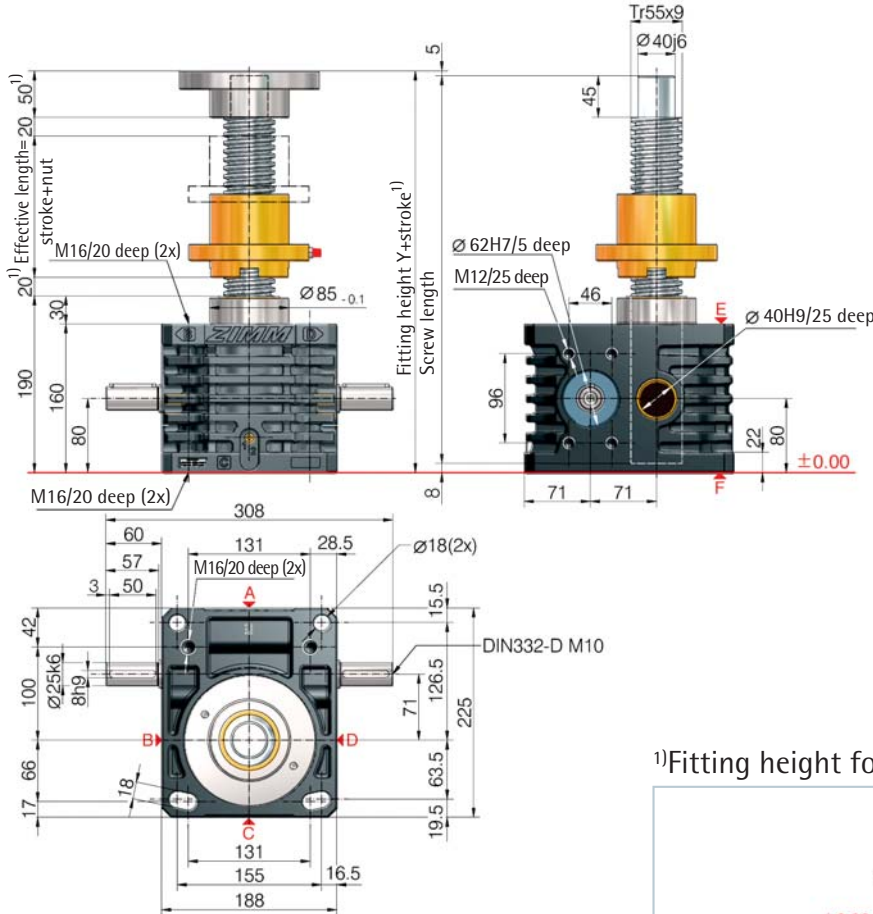

¹⁾Fitting height for 0-stroke, with Tr 55x9 screw

All dimensions in mm	Duplex nut DM	Duplex nut DM with SIFA	Self-aligning nut PM
Bellocs FB	Y/A	Y/A	Y/A
without bellows FB	370/246	453/329	470/355
2x Z-100-FB-285	478/299	556/377	578/408
2x Z-100-FB-600	472/296	550/374	572/405
2x Z-100-FB-1000	588/354	666/432	688/463
2x Z-100-FB-1500	688/404	766/482	788/513

Detailed instructions for determining the length can be found in Section 8

100 kN

Technical data series Z-100-S / Z-100-R

- max. compressive/tensile force, static - 100 kN (10 t)
- max. compressive/tensile force, dynamic - see duty cycle curves
- Nominal speed - 1500 rpm
- max. drive shaft speed - 1800 rpm
- Screw size standard - Tr 55x9²⁾
- Gear ratio - 9:1 (N) / 36:1 (L)
- Housing material - GGG-50, corrosion-resistant
- Worm shaft - steel, case-hardened, ground
- Weight of screw jack body - 29 kg
- Weight of screw/m - 15.7 kg
- Gearbox lubrication - synthetic fluid grease
- Screw lubrication - grease lubrication
- Gearbox operating temperature - max. 60°C, higher on request
- Moment of inertia - N: 12.53 kg cm² / L: 4.75 kg cm²
- Input torque (at 1500 rpm) - max. 53.4 Nm (N) / max. 13.5 Nm (L)
- Drive-through torque - max. 540 Nm

- Drive torque M_G (Nm) - F (kN) \times 0.72³⁾⁵⁾ + M_L (N-normal)
- Breakaway torque - F (kN) \times 0.23³⁾⁵⁾ + M_L (L-low speed)
- Idling torque⁴⁾ M_L (Nm) - Drive torque M_G \times 1.5
- 1.68 (N-normal) / 1.02 (L-low speed)

Between gearbox and nut or nut and end of thread, provide for a safety distance of (minimum) 20 mm!
See Section 7 for the checklist.

Important information

- 1) - extension if a bellows or spiral spring is fitted: see the table or Section 8
- 2) - Tr 55x9 is standard, also available: double-pitch, stainless steel, left-handed, increased screw Tr 60x9 (only for the R version)
- 3) - factor includes efficiency, ratio and 30% safety
- 4) - at 20°C, can be higher when new
- 5) - for a 9 mm screw pitch



Z-150-S translating screw 150 kN

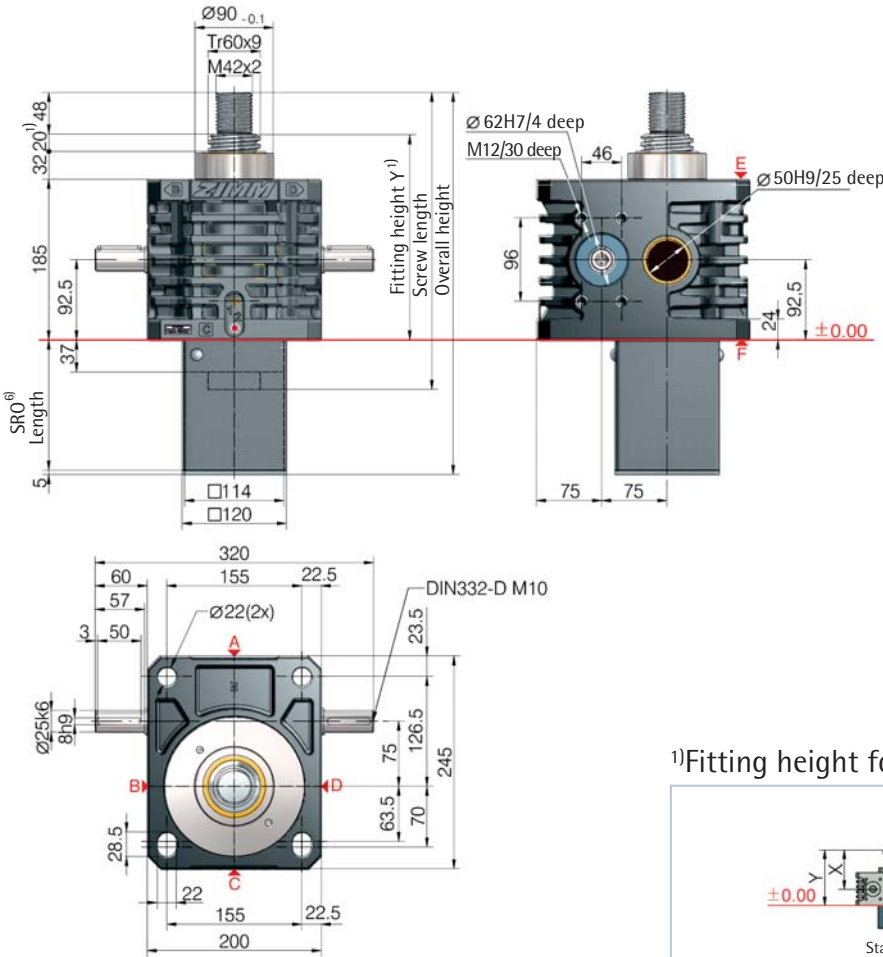

UNIQUE:
Screw lubrication
during operation

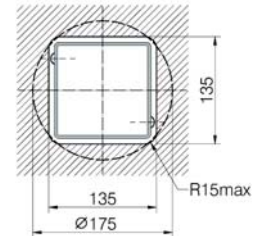
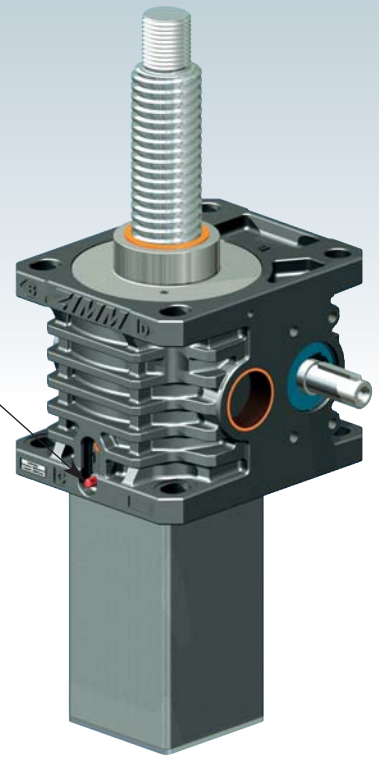

¹⁾Fitting height for 0-stroke, with Tr 60x9 screw

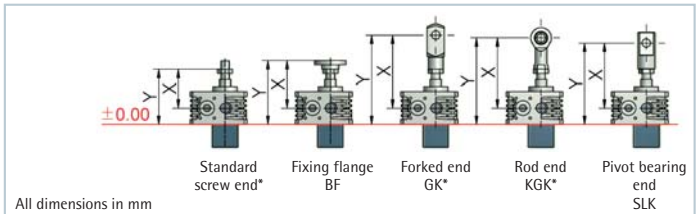

Bellocs FB	X/Y	X/Y	X/Y	X/Y	X/Y
without bellocs FB	145/237	195/287	313/405	305/397	300/392
Z-150-FB-350	198/290	223/315	366/458	358/450	328/420
Z-150-FB-600	220/312	245/337	388/480	380/472	350/442
Z-150-FB-1000	278/370	303/395	446/538	438/530	408/500
Z-150-FB-1500	328/420	353/445	496/588	488/580	458/550

*with bellows fixing ring Z-150-FBR

⁶⁾Protective tube length SRO with Tr 60x9 screw

Without escape/rotation protection	Escape/rotation protection	Rotation protection, with limit switch set ES
87+stroke	117+stroke	149+stroke

Standard ratios

Type	Version	Speed	Standard screw ²⁾	i	Stroke per drive shaft rotation ⁵⁾
Z-150-SN	Translating	Normal	Tr 60x9	9:1	1.00 mm
Z-150-SL	screw	Low speed		36:1	0.25 mm
Z-150-RN	Rotating	Normal	Tr 60x9	9:1	1.00 mm
Z-150-RL	screw	Low speed		36:1	0.25 mm

Screw jack mounting



Duty cycle thermal limit, for S+R

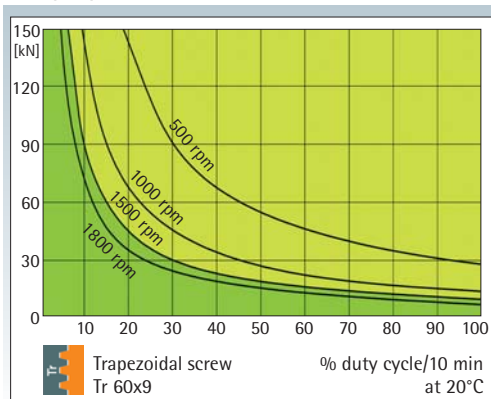

These curves are for guidance under standard industrial conditions (ambient temperature etc.) and correct maintenance (lubrication etc.). The max. input drive torques for optimum service life are at the right page - technical data (1500 rpm)

KGT:
% duty cycle
2 times to
4 times higher

Trapezoidal screw

Tr



Z-150-R rotating screw 150 kN

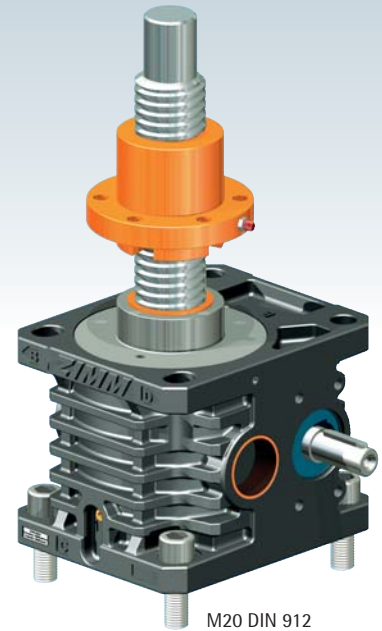
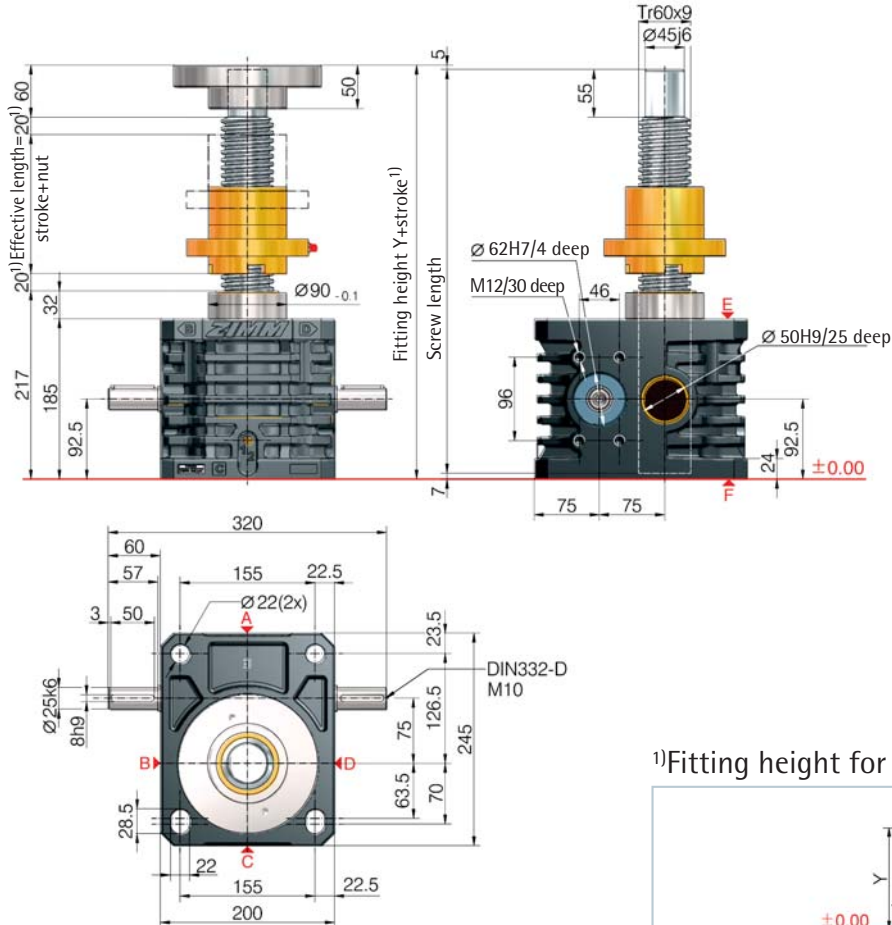

¹⁾Fitting height for 0-stroke, with Tr 60x9 screw

All dimensions in mm	Duplex nut DM	Duplex nut DM with SIFA	Self-aligning nut PM
Bellocs FB	Y/A	Y/A	Y/A
without bellows FB	432/277	528/373	527/402
2x Z-150-FB-300	480/305	571/396	575/430
2x Z-150-FB-600	524/327	615/418	619/452
2x Z-150-FB-1000	640/385	731/476	735/510
2x Z-150-FB-1500	740/435	831/526	835/560

Detailed instructions for determining the length can be found in Section 8

150 kN

Technical data series Z-150-S / Z-150-R

max. compressive/tensile force, static	- 150 kN (15 t)
max. compressive/tensile force, dynamic	- see duty cycle curves
Nominal speed	- 1500 rpm
max. drive shaft speed	- 1800 rpm
Screw size standard	- Tr 60x9 ²⁾
Gear ratio	- 9:1 (N) / 36:1 (L)
Housing material	- GGG-50, corrosion-resistant
Worm shaft	- steel, case-hardened, ground
Weight of screw jack body	- 42 kg
Weight of screw/m	- 19 kg
Gearbox lubrication	- synthetic fluid grease
Screw lubrication	- grease lubrication
Gearbox operating temperature	- max. 60°C, higher on request
Moment of inertia	- N: 22.47 kg cm ² / L: 7.96 kg cm ²
Input torque (at 1500 rpm)	- max. 75.1 Nm (N) / max. 20.7 Nm (L)
Drive-through torque	- max. 540 Nm

Drive torque M_G (Nm)	- F (kN) \times 0.75 ³⁾ + M_L (N-normal)
Breakaway torque	- F (kN) \times 0.25 ³⁾ + M_L (L-low speed)
Idling torque ⁴⁾ M_L (Nm)	- Drive torque M_G \times 1.5
	- 1.90 (N-normal) / 1.20 (L-low speed)

Between gearbox and nut or nut and end of thread, provide for a safety distance of (minimum) 20 mm!

See Section 7 for the checklist.

Important information

- extension if a bellows or spiral spring is fitted: see the table or Section 8
- Tr 60x9 is standard, also available: double-pitch, stainless steel, left-handed, increased screw Tr 80x16 (only for the R version)
- factor includes efficiency, ratio and 30% safety
- at 20°C, can be higher when new
- for a 9 mm screw pitch



Z-250-S translating screw 250 kN

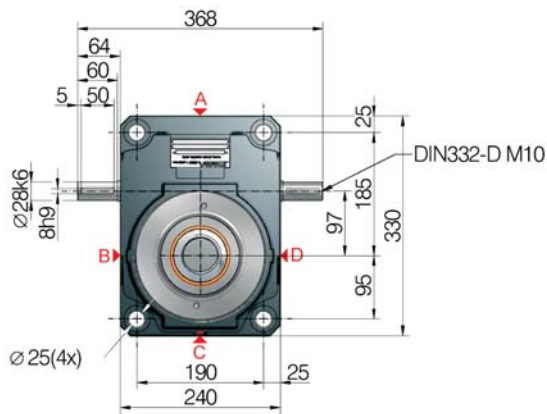
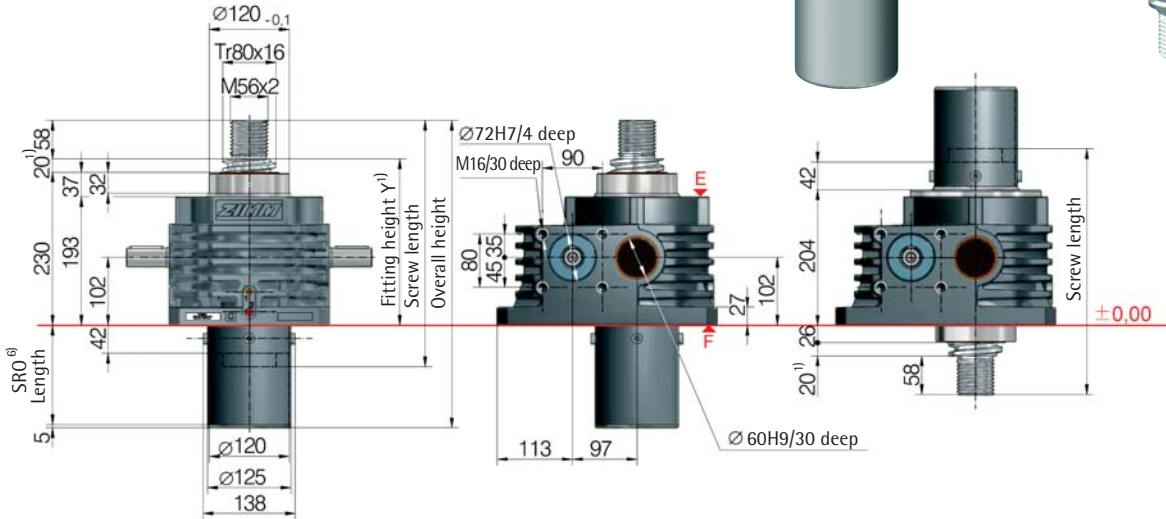
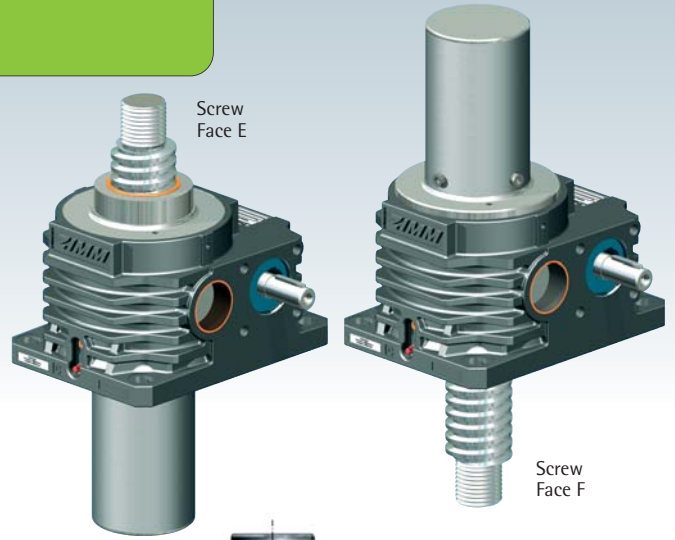

Opening for protective tube SRO

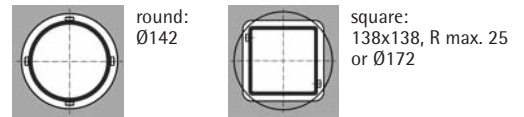

6) Protective tube length SRO with Tr 80x16 screw

only screw	with escape protection AS	with rotation protection VS	with VS and limit switch set ES
○ Ø125	○ Ø125	□ 120x120	□ 120x120
92+stroke	122+stroke	122+stroke	150+stroke

1) Fitting height for 0-stroke, with Tr 80x16 screw

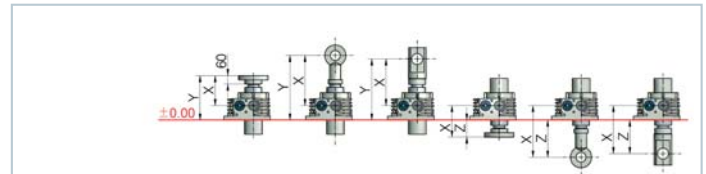

All dimensions in mm	BF	KGK*	SLK	BF	KGK*	SLK
Bellows FB	X/Y	X/Y	X/Y	X/Z	X/Z	X/Z
without bellows FB	208/310	348/450	328/430	208/106	348/246	328/226
Z-250-FB-390	276/378	441/543	396/498	276/174	441/339	396/294
Z-250-FB-600	258/360	423/525	378/480	258/156	423/321	378/276
Z-250-FB-1000	316/418	481/583	436/538	316/214	481/379	436/334
Z-250-FB-1500	366/468	531/633	486/588	366/264	531/429	486/384

*with bellows fixing ring Z-250-FBR

Standard ratios

Type	Version	Speed	Standard screw ²⁾	i	Stroke per drive shaft rotation ⁵⁾
Z-250-SN	Translating	Normal	Tr 80x16	10.66:1	1.5 mm
Z-250-SL	screw	Low speed		32:1	0.5 mm
Z-250-RN	Rotating	Normal	Tr 80x16	10.66:1	1.5 mm
Z-250-RL	screw	Low speed		32:1	0.5 mm

Screw jack mounting

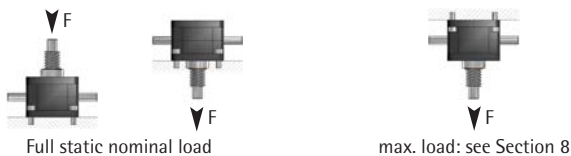

Duty cycle thermal limit, for S+R

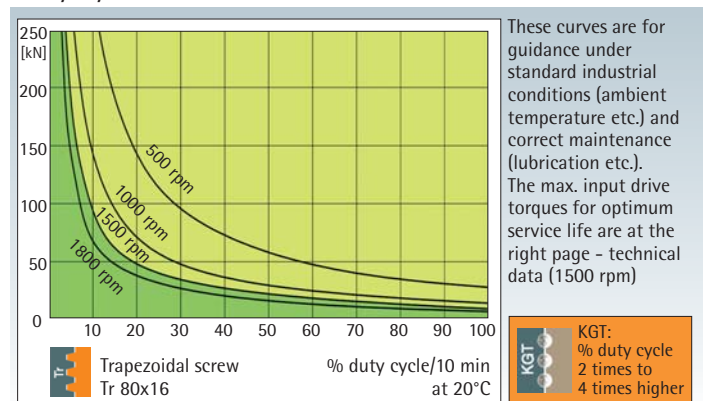

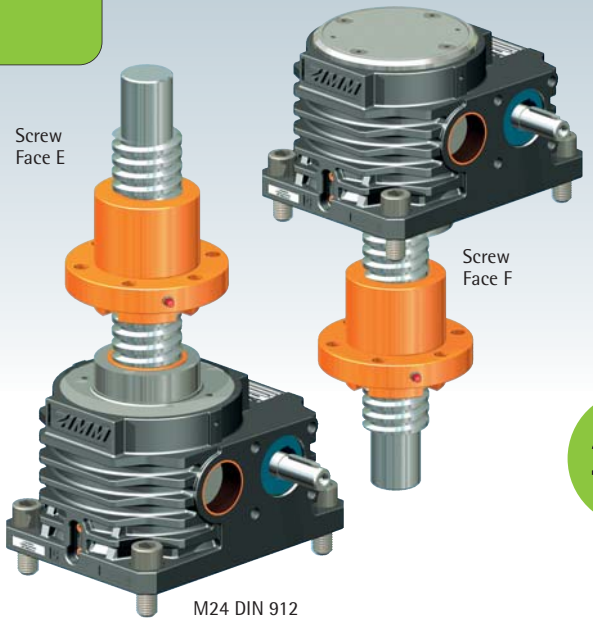

Z-250-R rotating screw 250 kN

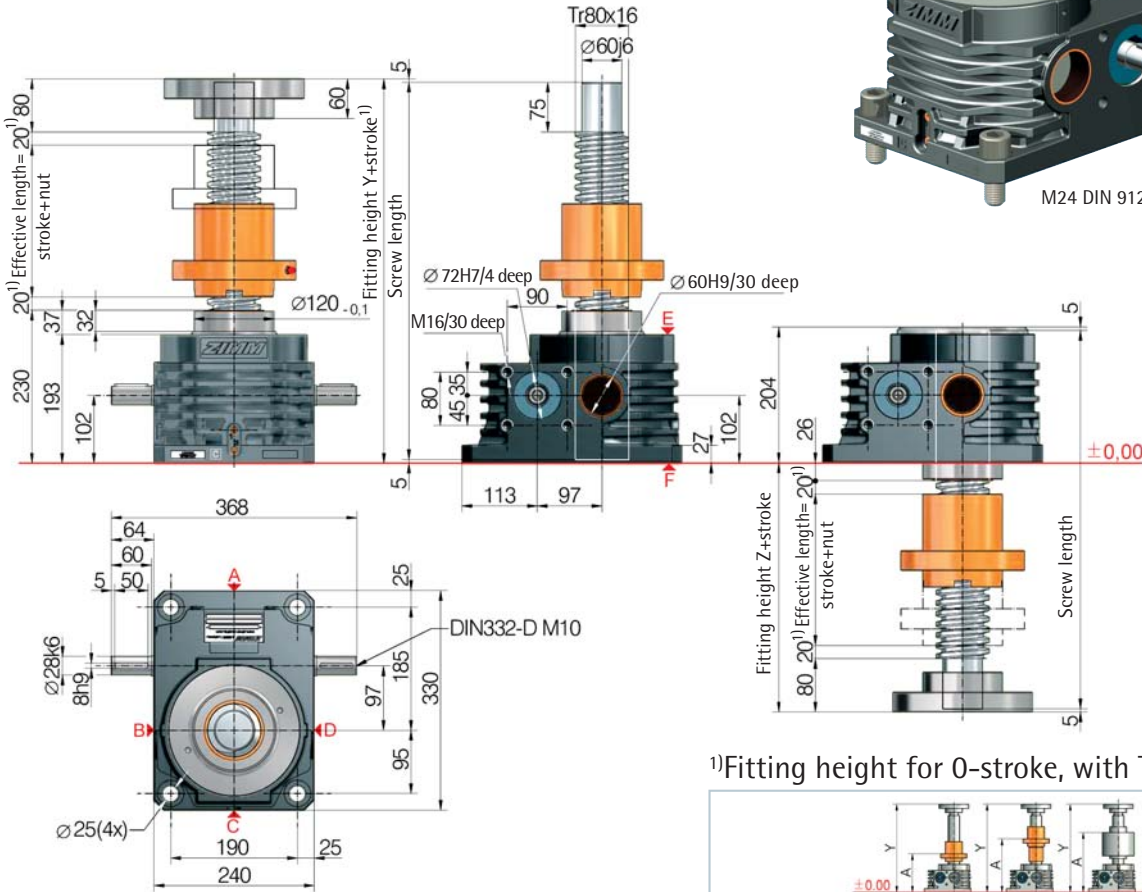

1) Fitting height for 0-stroke, with Tr 80x16 screw

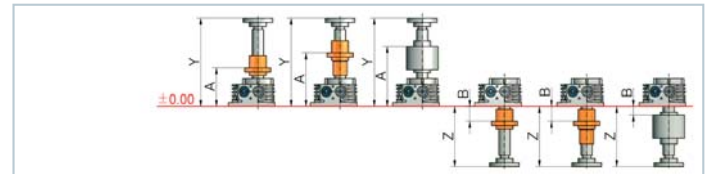

All dimensions in mm	DM	DM with SIFA	PM	DM	DM with SIFA	DM
Bellows FB	Y/A	Y/A	Y/A	Z/B	Z/B	Z/B
without bellows FB	490/305	600/415	574/434	286/131	396/131	370/86
2x Z-250-FB-390	608/373	712/477	692/502	404/199	514/199	488/154
2x Z-250-FB-600	572/355	676/459	656/484	368/181	478/181	452/136
2x Z-250-FB-1000	688/413	792/517	772/542	484/239	594/239	568/194
2x Z-250-FB-1500	788/463	892/567	872/592	584/289	694/289	668/244

Detailed instructions for determining the length can be found in Section 8

250 kN

Technical data series Z-250-S / Z-250-R

max. compressive/tensile force, static	- 250 kN (25 t)
max. compressive/tensile force, dynamic	- see duty cycle curves
Nominal speed	- 1500 rpm
max. drive shaft speed	- 1800 rpm
Screw size standard	- Tr 80x16 ²⁾
Gear ratio	- 10.66:1 (N) / 32:1 (L)
Housing material	- GGG-50, corrosion-resistant
Worm shaft	- steel, case-hardened, ground
Weight of screw jack body	- 59 kg
Weight of screw/m	- 32 kg
Gearbox lubrication	- synthetic gear oil
Screw lubrication	- grease lubrication
Gearbox operating temperature	- max. 60°C, higher on request
Moment of inertia	- N: 53.8 kg cm ² / L: 22.0 kg cm ²
Input torque (at 1500 rpm)	- max. 152 Nm (N) / max. 41.4 Nm (L)
Drive-through torque	- max. 770 Nm

Drive torque M_G (Nm)	- F (kN) \times 0.94 ³⁾⁵⁾ + M_L (N-normal)
	- F (kN) \times 0.37 ³⁾⁵⁾ + M_L (L-low speed)
Breakaway torque	- Drive torque $M_G \times 1.5$
Idling torque ⁴⁾ M_L (Nm)	- 2.64 (N-normal) / 1.94 (L-low speed)

Between gearbox and nut or nut and end of thread, provide for a safety distance of (minimum) 20 mm!
See Section 7 for the checklist.

- Important information**
- 1) - extension if a bellows or spiral spring is fitted: see the table or Section 8
 - 2) - Tr 80x16 is standard, also available: double-pitch, stainless steel, left-handed, increased screw Tr 100x16 (only for the R version)
 - 3) - factor includes efficiency, ratio and 30% safety
 - 4) - at 20°C, can be higher when new
 - 5) - for a 16 mm screw pitch



Z-350-S translating screw 350 kN

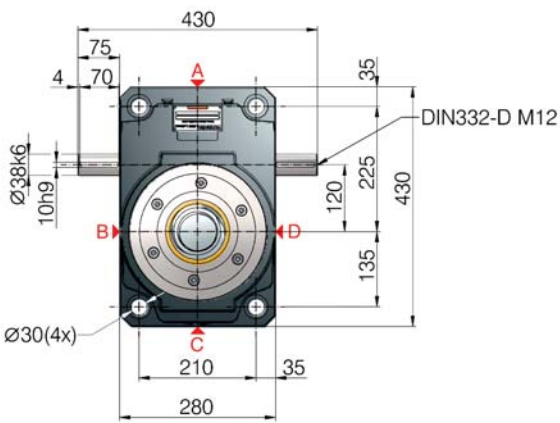
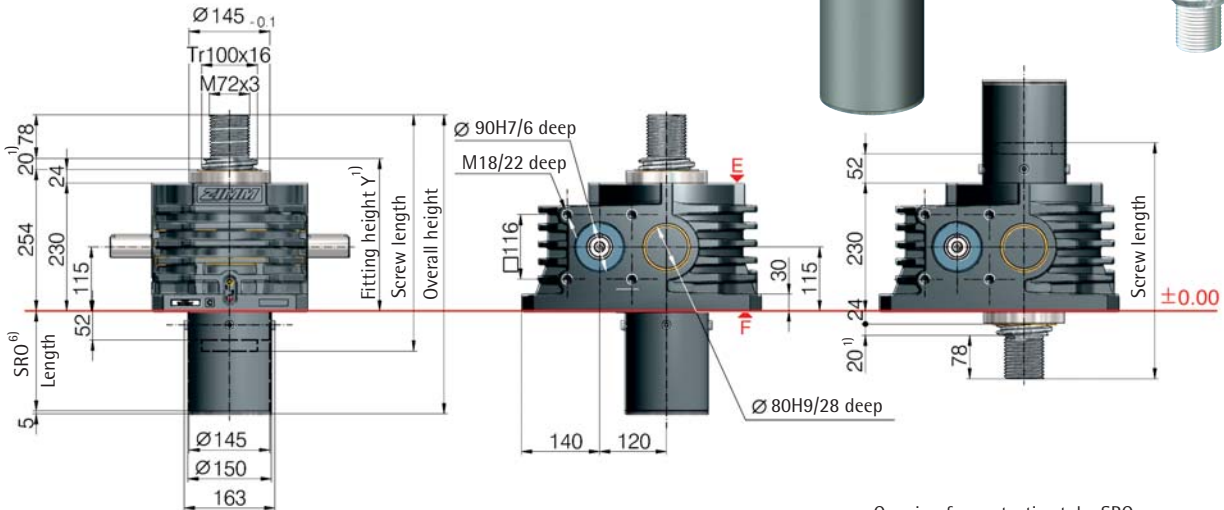
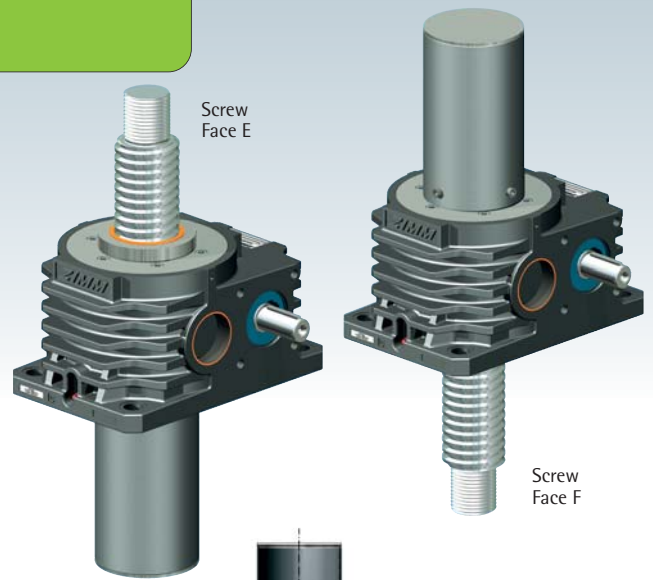

Opening for protective tube SRO

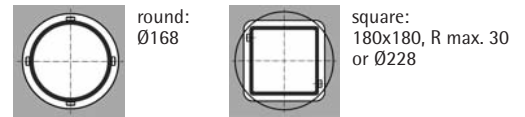

¹)Fitting height for 0-stroke, with Tr 100x16 screw

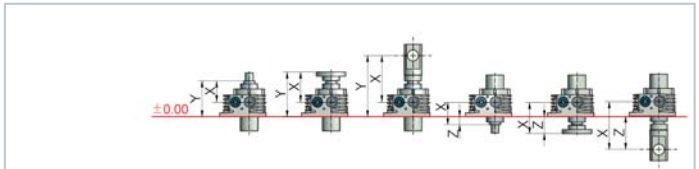

⁶)Protective tube length SRO with Tr 100x16 screw

only screw	with escape protection AS	with rotation protection VS	with VS and limit switch set ES
○ Ø150	○ Ø150	□ 160x160	□ 160x160
107+stroke	142+stroke	142+stroke	166+stroke

All dimensions in mm	BF		SLK		BF		SLK	
	X/Y	X/Y	X/Y	X/Z	X/Z	X/Z	X/Z	
Bellocs FB								
without bellocs FB	159/274	239/354	354/469	159/44	239/124	354/239		
Z-350-FB-600	262/377	317/432	432/547	262/147	317/202	432/317		
Z-350-FB-900	270/385	325/440	440/555	270/155	325/210	440/325		
Z-350-FB-1500	342/457	397/512	512/627	342/227	397/282	512/397		

Standard ratios

Type	Version	Speed	Standard screw ²⁾	i	Stroke per drive shaft rotation ⁵⁾
Z-350-SN	Translating	Normal	Tr 100x16	10.66:1	1.5 mm
Z-350-SL	screw	Low speed		32:1	0.5 mm
Z-350-RN	Rotating	Normal	Tr 100x16	10.66:1	1.5 mm
Z-350-RL	screw	Low speed		32:1	0.5 mm

Screw jack mounting



Duty cycle thermal limit, for S+R

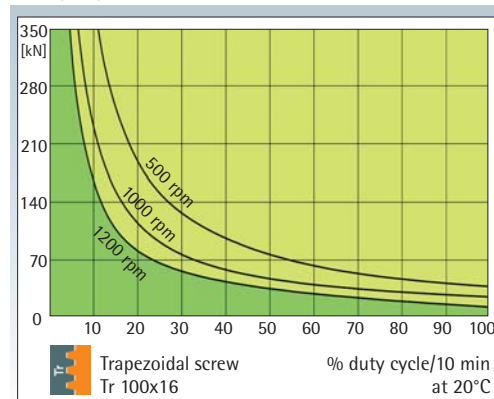

These curves are for guidance under standard industrial conditions (ambient temperature etc.) and correct maintenance (lubrication etc.). The max. input drive torques for optimum service life are at the right page - technical data (1000 rpm)

KGT: % duty cycle 2 times to 4 times higher



Z-350-R rotating screw 350 kN

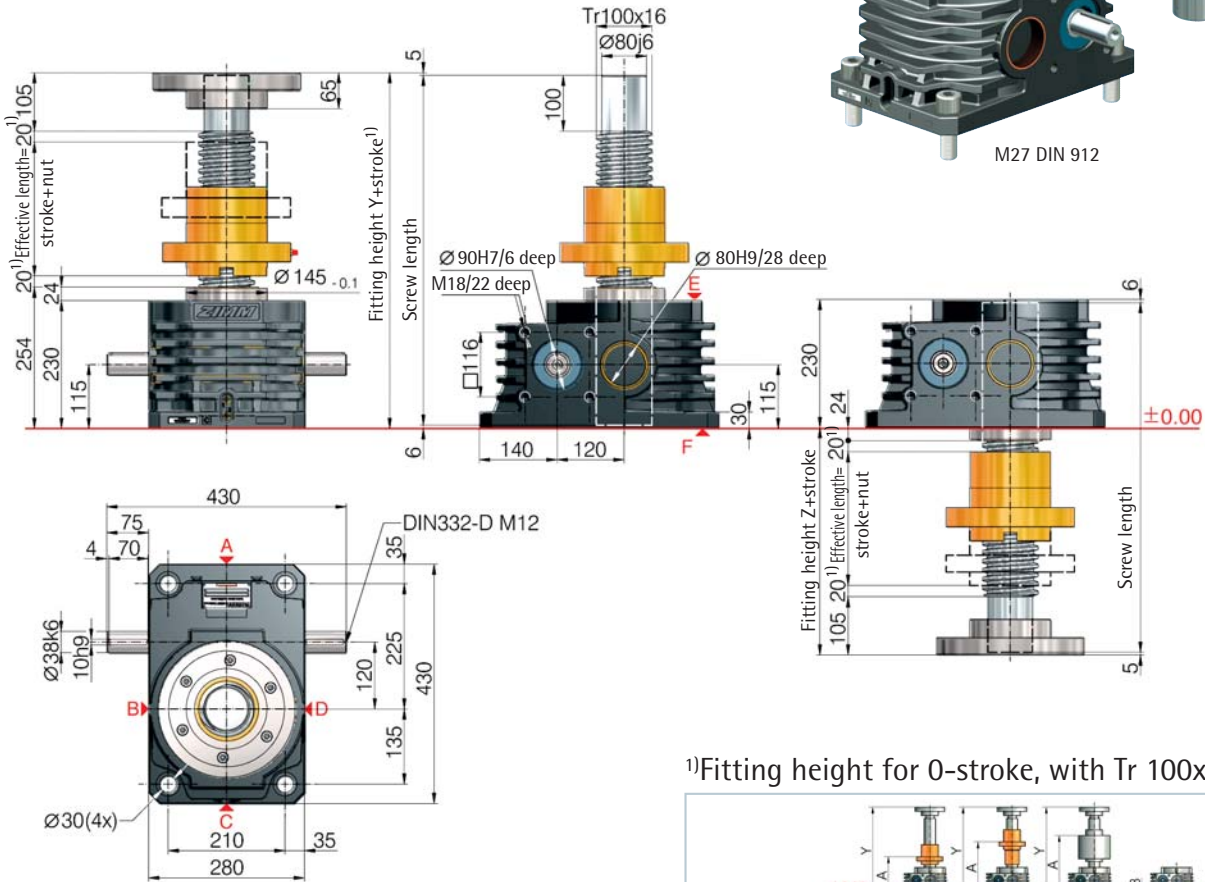
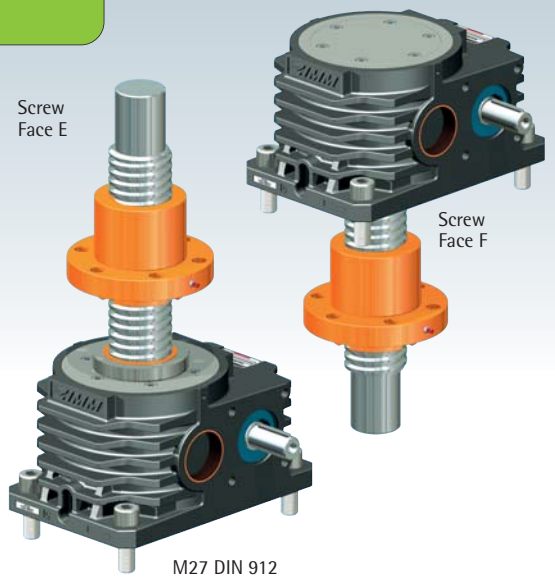

1) Fitting height for 0-stroke, with Tr 100x16 screw

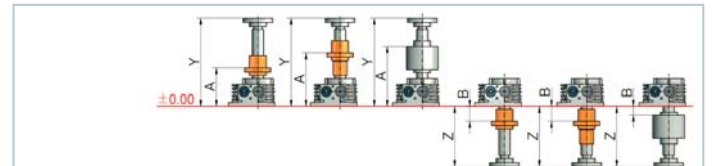

All dimensions in mm	DM	DM with SIFA	PM	DM	DM with SIFA	DM
Bellows FB	Y/A	Y/A	Y/A	Z/B	Z/B	Z/B
without bellows FB	559/334	669/444	674/509	329/144	439/144	444/84
2x Z-350-FB-600	677/412	781/516	792/587	447/222	557/222	562/162
2x Z-350-FB-900	693/420	797/524	808/595	463/230	573/230	578/170
2x Z-350-FB-1500	837/492	941/596	952/667	607/302	717/302	722/242

Detailed instructions for determining the length can be found in Section 8

350 kN

Technical data series Z-350-S / Z-350-R

- max. compressive/tensile force, static - 350 kN (35 t)
- max. compressive/tensile force, dynamic - see duty cycle curves
- Nominal speed - 1000 rpm
- max. drive shaft speed - 1200 rpm
- Screw size standard - Tr 100x16²⁾
- Gear ratio - 10.66:1 (N) / 32:1 (L)
- Housing material - GGG-50, corrosion-resistant
- Worm shaft - steel, case-hardened, ground
- Weight of screw jack body - 112 kg
- Weight of screw/m - 52 kg
- Gearbox lubrication - synthetic gear oil
- Screw lubrication - grease lubrication
- Gearbox operating temperature - max. 60°C, higher on request
- Moment of inertia - N: 148.9 kg cm² / L: 66.1 kg cm²
- Input torque (at 1000 rpm) - max. 265 Nm (N) / max. 100 Nm (L)
- Drive-through torque - max. 1800 Nm

- Drive torque M_G (Nm) - F (kN) \times 1.09³⁾⁵⁾ + M_L (N-normal)
- F (kN) \times 0.42³⁾⁵⁾ + M_L (L-low speed)
- Breakaway torque - Drive torque M_G \times 1.5
- Idling torque⁴⁾ M_L (Nm) - 3.24 (N-normal) / 2.20 (L-low speed)

Between gearbox and nut or nut and end of thread, provide for a safety distance of (minimum) 20 mm!
See Section 7 for the checklist.

Important information

- 1) - extension if a bellows or spiral spring is fitted: see the table or Section 8
- 2) - Tr 100x16 is standard, also available: double-pitch, stainless steel, left-handed, increased screw Tr 120x16 (only for the R version)
- 3) - factor includes efficiency, ratio and 30% safety
- 4) - at 20°C, can be higher when new
- 5) - for a 16 mm screw pitch



Z-500-S translating screw 500 kN

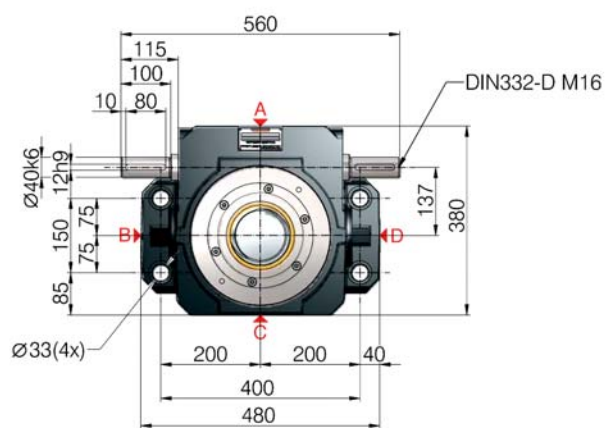
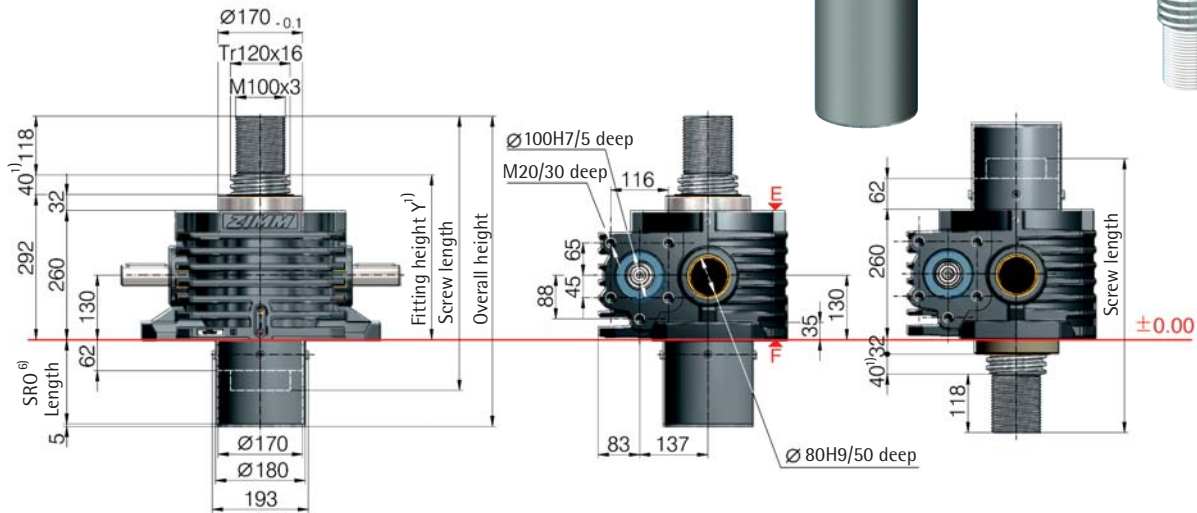
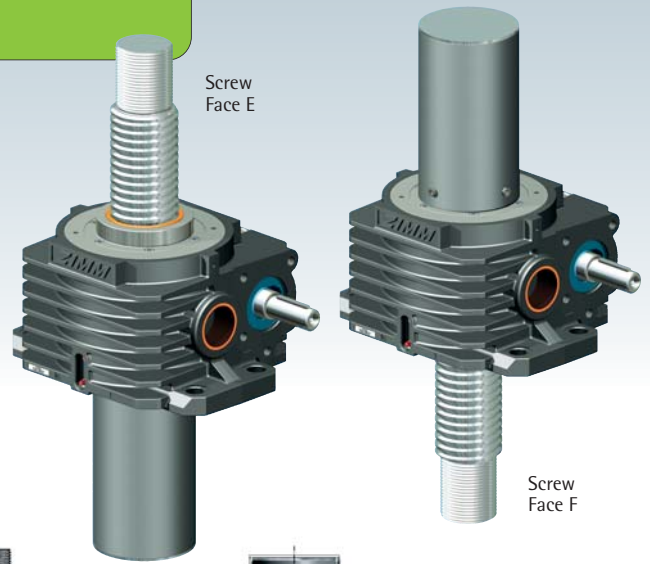

Opening for protective tube SRO

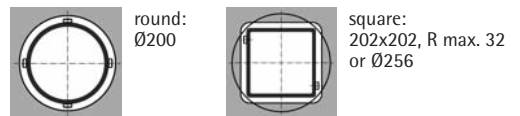

6) Protective tube length SRO with Tr 120x16 screw

only screw	with escape protection AS	with rotation protection VS	with VS and limit switch set ES
○ Ø180	○ Ø180	□ 180x180	□ 180x180
157+stroke	197+stroke	197+stroke	197+stroke

1) Fitting height for 0-stroke, with Tr 120x16 screw

All dimensions in mm	BF		SLK	BF		SLK
	X/Y	X/Y	X/Y	X/Z	X/Z	X/Z
without bellows FB	202/332	322/452	447/577	202/72	322/192	447/317

Standard ratios

Type	Version	Speed	Standard screw ²⁾	i	Stroke per drive shaft rotation ⁵⁾
Z-500-SN	Translating	Normal	Tr 120x16	10.66:1	1.5 mm
Z-500-SL	screw	Low speed		32:1	0.5 mm
Z-500-RN	Rotating	Normal	Tr 120x16	10.66:1	1.5 mm
Z-500-RL	screw	Low speed		32:1	0.5 mm

Screw jack mounting



Duty cycle thermal limit, for S+R

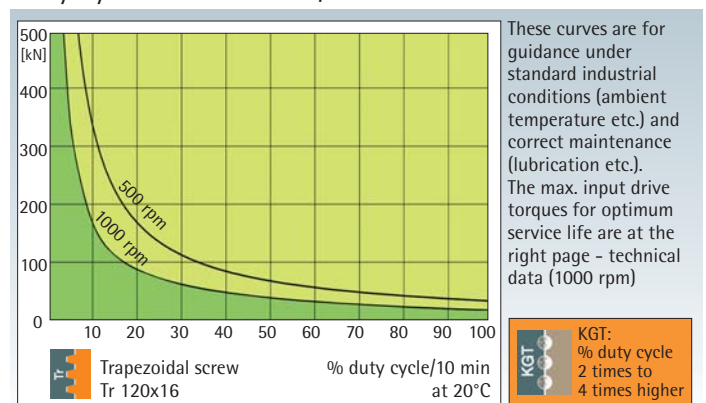

Trapezoidal screw

Tr



Z-500-R rotating screw 500 kN

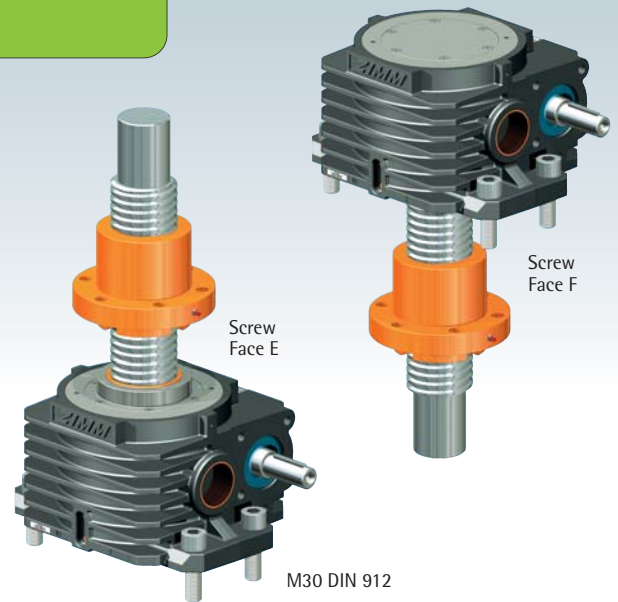
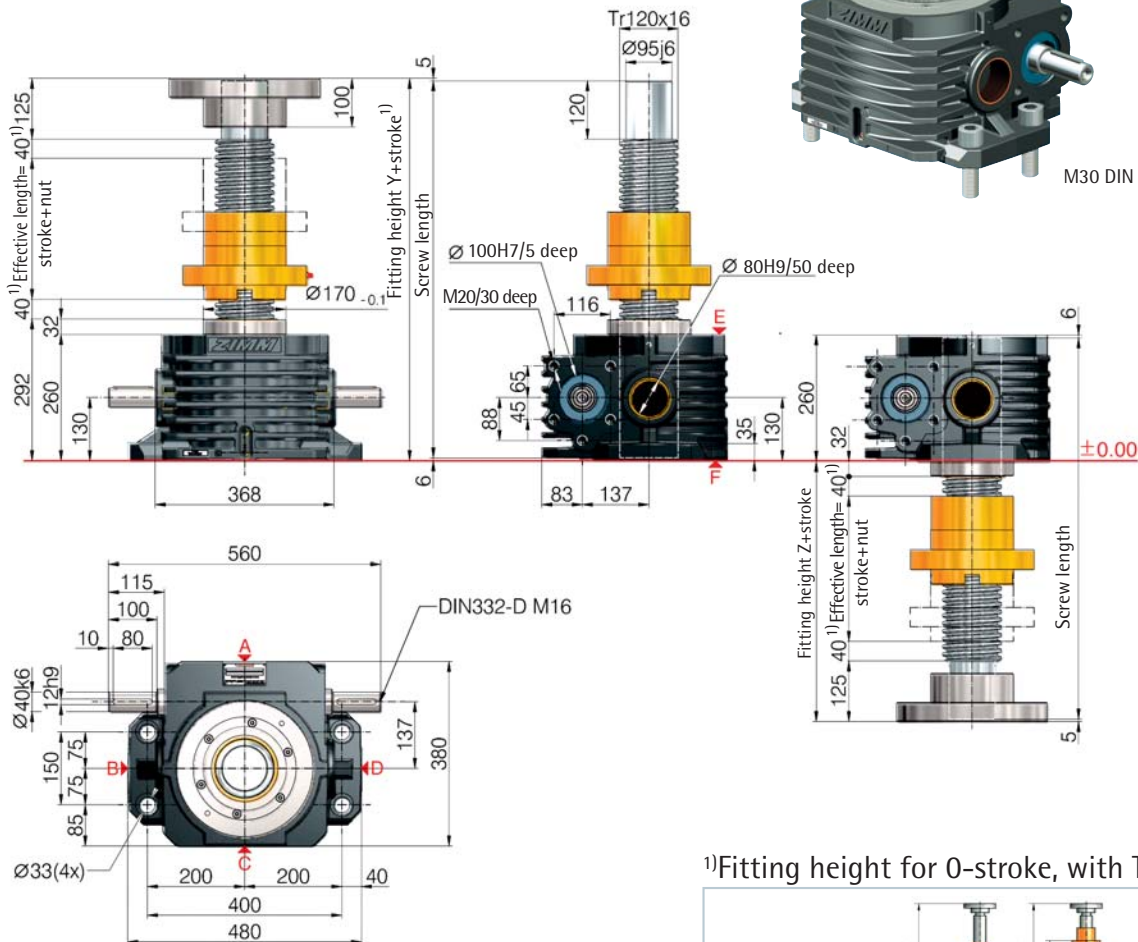

500 kN

¹⁾Fitting height for 0-stroke, with Tr 120x16 screw

All dimensions in mm	DM	DM with SIFA	DM	DM with SIFA
	Y/A	Y/A	Z/B	Z/B
without bellows FB	677/402	800/525	417/182	540/182

Detailed instructions for determining the length can be found in Section 8

Technical data series Z-500-S / Z-500-R

max. compressive/tensile force, static	- 500 kN (50 t)
max. compressive/tensile force, dynamic	- see duty cycle curves
Nominal speed	- 1000 rpm
max. drive shaft speed	- 1000 rpm
Screw size standard	- Tr 120x16 ²⁾
Gear ratio	- 10.66:1 (N) / 32:1 (L)
Housing material	- GGG-50, corrosion-resistant
Worm shaft	- steel, case-hardened, ground
Weight of screw jack body	- 168 kg
Weight of screw/m	- 77 kg
Gearbox lubrication	- synthetic gear oil
Screw lubrication	- grease lubrication
Gearbox operating temperature	- max. 60°C, higher on request
Moment of inertia	- N: 310.2 kg cm ² / L: 127.8 kg cm ²
Input torque (at 1000 rpm)	- max. 408 Nm (N) / max. 170 Nm (L)
Drive-through torque	- max. 1940 Nm

Drive torque M_G (Nm)	- F (kN) \times 1.24 ³⁾ + M_L (N-normal)
Breakaway torque	- F (kN) \times 0.50 ³⁾ + M_L (L-low speed)
Idling torque ⁴⁾ M_L (Nm)	- Drive torque M_G \times 1.5
	- 3.96 (N-normal) / 2.84 (L-low speed)

Between gearbox and nut or nut and end of thread, provide for a safety distance of (minimum) 40 mm!
See Section 7 for the checklist.

Important information

- extension if a bellows or spiral spring is fitted: see Section 8
- Tr 120x16 is standard, also available: double-pitch, stainless steel, left-handed, increased screw Tr 140x20 (only for the R version)
- factor includes efficiency, ratio and 30% safety
- at 20°C, can be higher when new
- for a 16 mm screw pitch



Z-750-S translating screw 750 kN

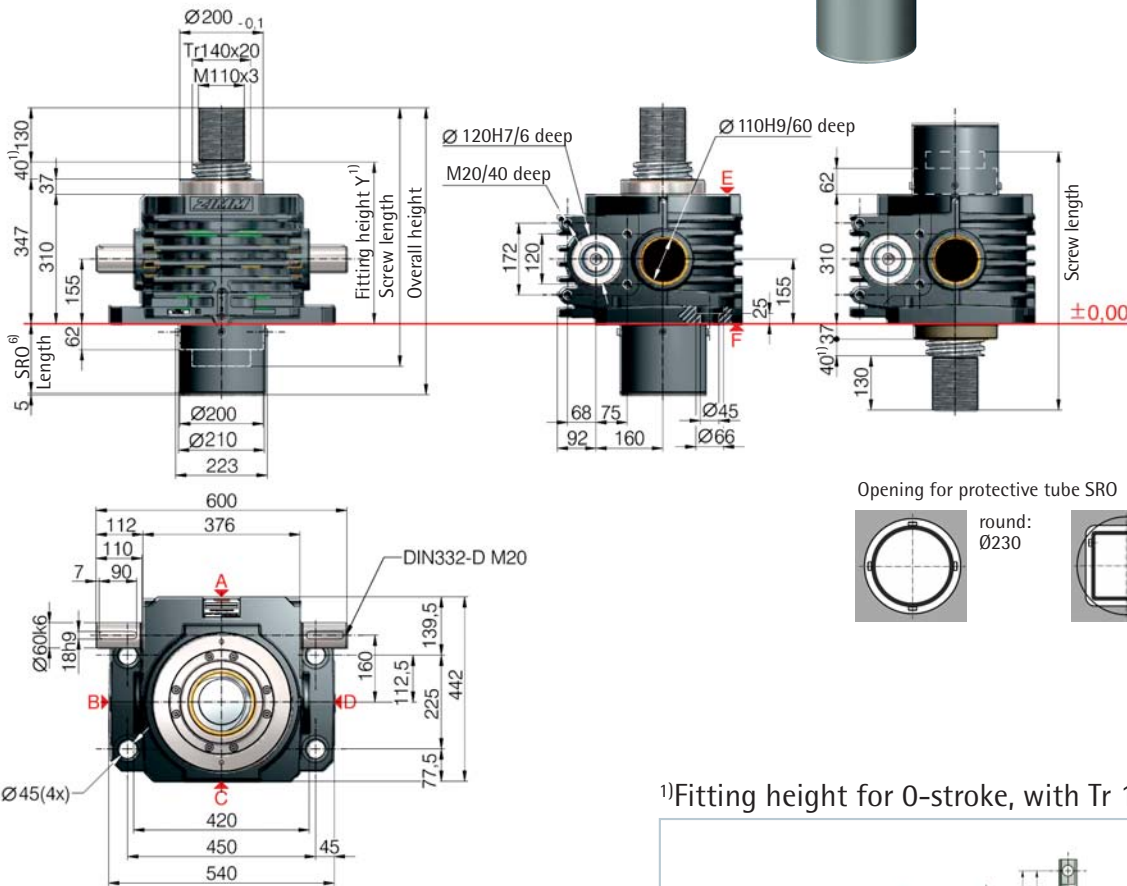
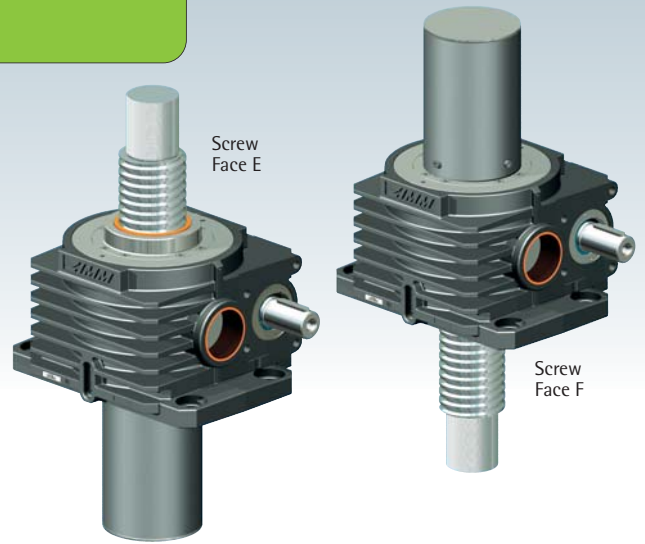

Opening for protective tube SRO

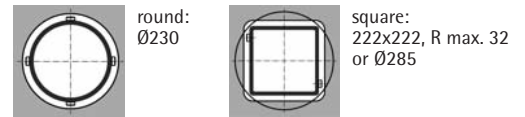

6) Protective tube length SRO with Tr 140x20 screw

only screw	with escape protection AS	with rotation protection VS	with VS and limit switch set ES
○ Ø210	○ Ø210	□ 200x200	□ 200x200
157+stroke	197+stroke	197+stroke	205+stroke

1) Fitting height for 0-stroke, with Tr 140x20 screw

All dimensions in mm	BF		SLK	BF		SLK
	X/Y	X/Y	X/Y	X/Z	X/Z	X/Z
without bellows FB	232/387	364/519	on request	232/77	364/209	on request

Standard ratios

Type	Version	Speed	Standard screw ²⁾	i	Stroke per drive shaft rotation ⁵⁾
Z-750-SN	Translating	Normal	Tr 140x20	13.33:1	1.5 mm
Z-750-SL	screw	Low speed		40:1	0.5 mm
Z-750-RN	Rotating	Normal	Tr 140x20	13.33:1	1.5 mm
Z-750-RL	screw	Low speed		40:1	0.5 mm

Screw jack mounting



Duty cycle thermal limit, for S+R

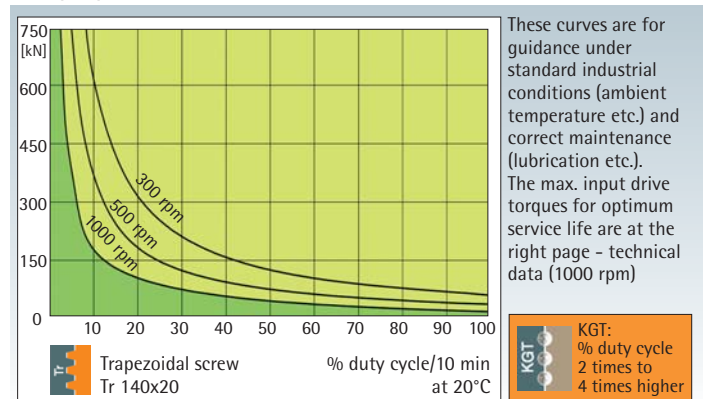

Trapezoidal screw

Tr



Z-750-R rotating screw 750 kN

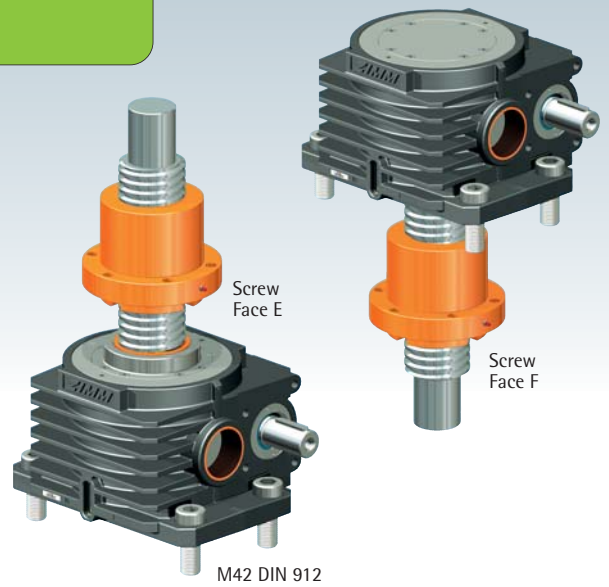
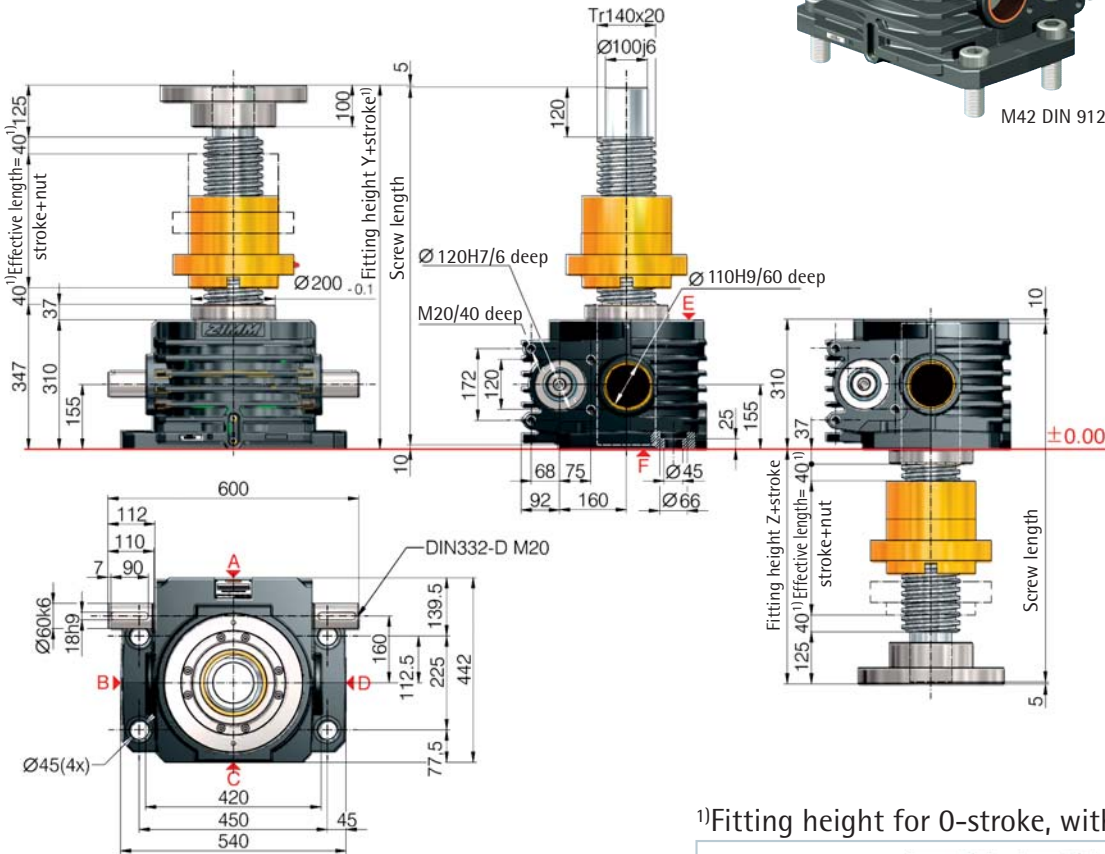

750 kN

Technical data series Z-750-S / Z-750-R

max. compressive/tensile force, static	- 750 kN (75 t)
max. compressive/tensile force, dynamic	- see duty cycle curves
Nominal speed	- 1000 rpm
max. drive shaft speed	- 1000 rpm
Screw size standard	- Tr 140x20 ²⁾
Gear ratio	- 13.33:1 (N) / 40:1 (L)
Housing material	- GGG-50, corrosion-resistant
Worm shaft	- steel, case-hardened, ground
Weight of screw jack body	- 262 kg
Weight of screw/m	- 104 kg
Gearbox lubrication	- synthetic gear oil
Screw lubrication	- grease lubrication
Gearbox operating temperature	- max. 60°C, higher on request
Moment of inertia	- N: 518.1 kg cm ² / L: 256.1 kg cm ²
Input torque (at 1000 rpm)	- max. 480 Nm (N) / max. 210 Nm (L)
Drive-through torque	- max. 4570 Nm

1) Fitting height for 0-stroke, with Tr 140x20 screw

All dimensions in mm	DM	DM with SIFA	DM	DM with SIFA
	Y/A	Y/A	Z/B	Z/B
without bellows FB	772/467	917/612	462/217	607/217

Detailed instructions for determining the length can be found in Section 8

Drive torque M_G (Nm)	- F (kN) \times 1.22 ³⁾⁵⁾ + M_L (N-normal) - F (kN) \times 0.54 ³⁾⁵⁾ + M_L (L-low speed)
Breakaway torque	- Drive torque $M_G \times 1.5$
Idling torque ⁴⁾ M_L (Nm)	- 7.28 (N-normal) / 4.42 (L-low speed)

Between gearbox and nut or nut and end of thread, provide for a safety distance of (minimum) 40 mm!
See Section 7 for the checklist.

Important information

- extension if a bellows or spiral spring is fitted: see Section 8
- Tr 140x20 is standard, also available: double-pitch, stainless steel, left-handed, increased screw Tr 160x20 (only for the R version)
- factor includes efficiency, ratio and 30% safety
- at 20°C, can be higher when new
- for a 20 mm screw pitch

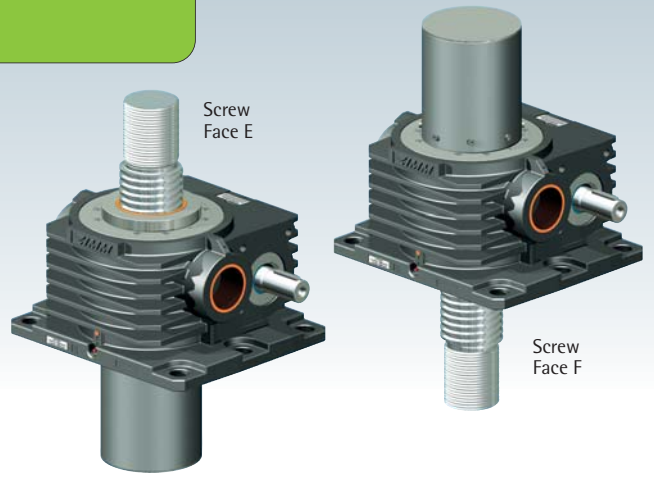

Z-1000-S translating screw 1,000 kN

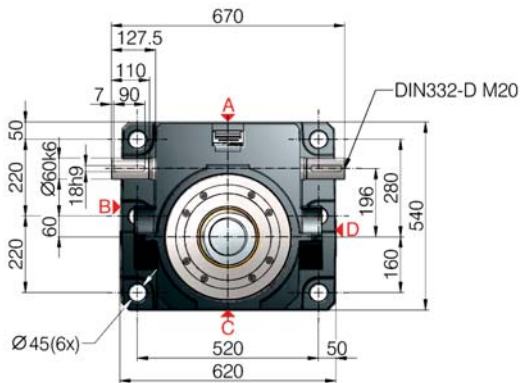
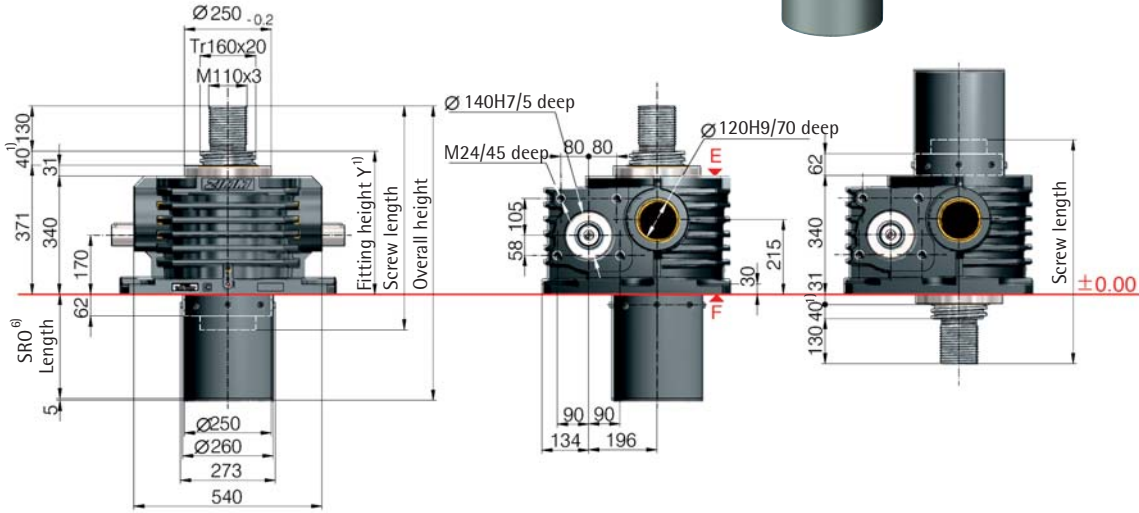

Opening for protective tube SRO

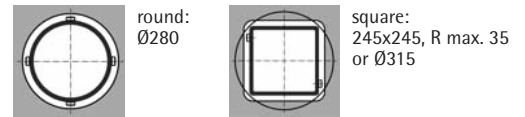

6) Protective tube length SRO with Tr 160x20 screw

only screw	with escape protection AS	with rotation protection VS	with VS and limit switch set ES
○ Ø260	○ Ø260	□ 220x220	□ 220x220
157+stroke	197+stroke	197+stroke	205+stroke

1) Fitting height for 0-stroke, with Tr 160x20 screw

All dimensions in mm	BF		SLK		BF		SLK	
	X/Y	X/Y	X/Y	X/Y	X/Z	X/Z	X/Z	X/Z
without bellows FB	196/411	328/543	on request	196/181	328/313	on request	on request	on request

Standard ratios

Type	Version	Speed	Standard screw ²⁾	i	Stroke per drive shaft rotation ⁵⁾
Z-1000-SN	Translating	Normal	Tr 160x20	13.33:1	1.5 mm
Z-1000-SL	screw	Low speed		40:1	0.5 mm
Z-1000-RN	Rotating	Normal	Tr 160x20	13.33:1	1.5 mm
Z-1000-RL	screw	Low speed		40:1	0.5 mm

Screw jack mounting



Duty cycle thermal limit, for S+R

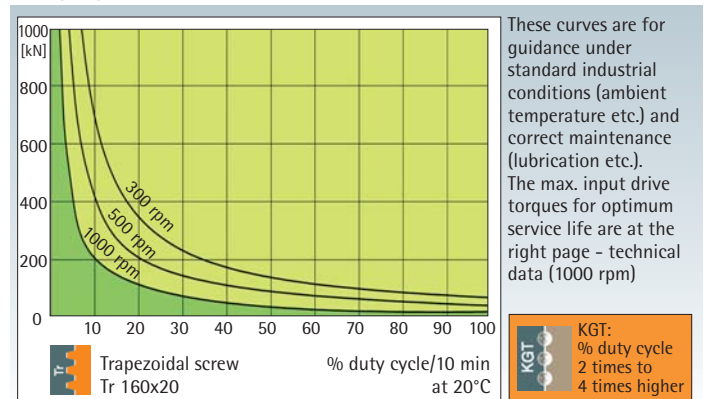



Z-1000-R rotating screw 1,000 kN

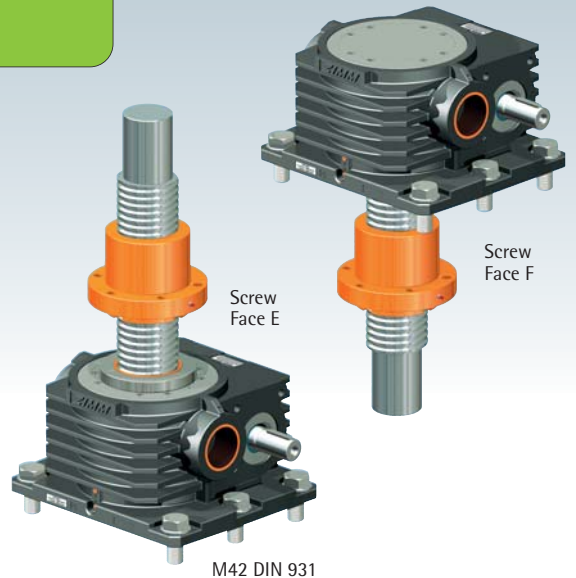
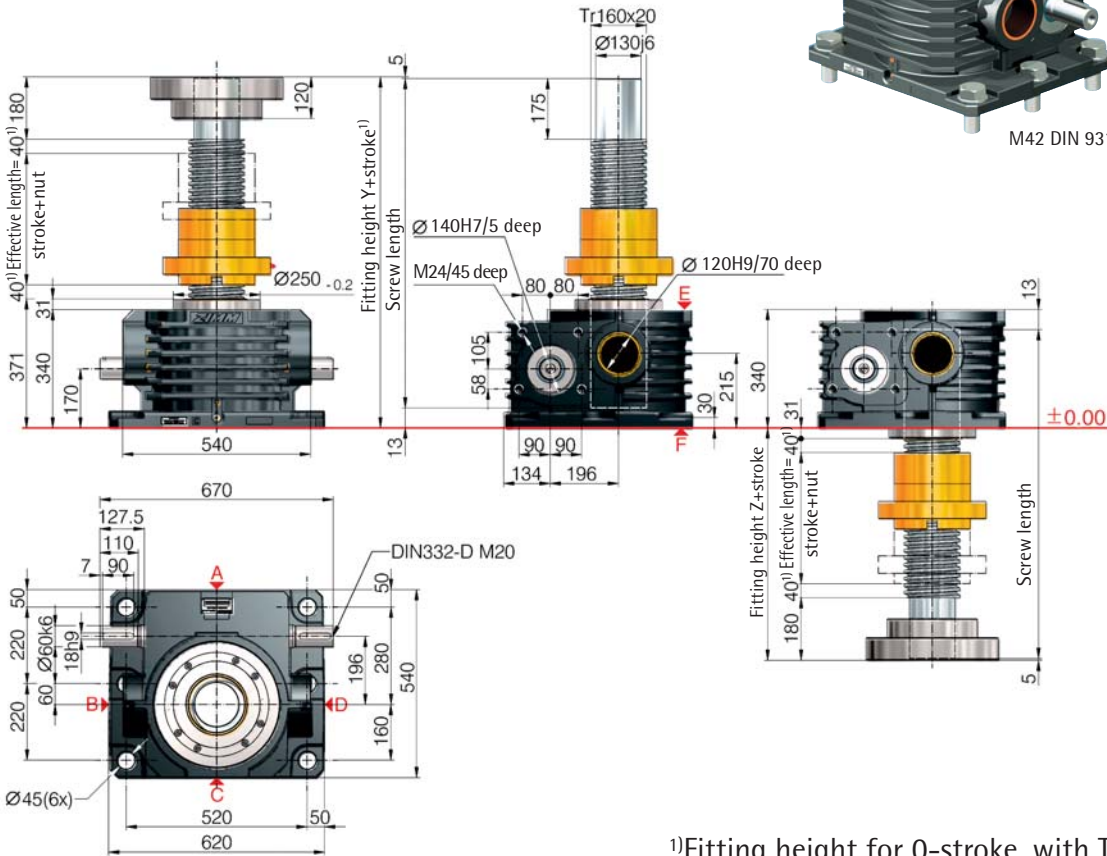

M42 DIN 931

1) Fitting height for 0-stroke, with Tr 160x20 screw

All dimensions in mm	DM	DM with SIFA	DM	DM with SIFA
	Y/A	Y/A	Z/B	Z/B
without bellows FB	951/521	1131/701	611/281	791/281

Detailed instructions for determining the length can be found in Section 8

1000 kN

Technical data series Z-1000-S / Z-1000-R

- max. compressive/tensile force, static - 1000 kN (100 t)
- max. compressive/tensile force, dynamic - see duty cycle curves
- Nominal speed - 1000 rpm
- max. drive shaft speed - 1000 rpm
- Screw size standard - Tr 160x20²⁾
- Gear ratio - 13.33:1 (N) / 40:1 (L)
- Housing material - GGG-50, corrosion-resistant
- Worm shaft - steel, case-hardened, ground
- Weight of screw jack body - 408 kg
- Weight of screw/m - 139 kg
- Gearbox lubrication - synthetic gear oil
- Screw lubrication - grease lubrication
- Gearbox operating temperature - max. 60°C, higher on request
- Moment of inertia - N: 1058.2 kg cm² / L: 459.2 kg cm²
- Input torque (at 1000 rpm) - max. 680 Nm (N) / max. 450 Nm (L)
- Drive-through torque - max. 4570 Nm

- Drive torque M_G (Nm) - F (kN) \times 1.32³⁾⁵⁾ + M_L (N-normal)
- Breakaway torque - F (kN) \times 0.51³⁾⁵⁾ + M_L (L-low speed)
- Idling torque⁴⁾ M_L (Nm) - Drive torque $M_G \times 1.5$
- 9.70 (N-normal) / 5.90 (L-low speed)

Between gearbox and nut or nut and end of thread, provide for a safety distance of (minimum) 40 mm!
See Section 7 for the checklist.

Important information

- 1) - extension if a bellows or spiral spring is fitted: see Section 8
- 2) - Tr 160x20 is standard, also available: double-pitch, stainless steel, left-handed, increased screw Tr 190x24 (only for the R version)
- 3) - factor includes efficiency, ratio and 30% safety
- 4) - at 20°C, can be higher when new
- 5) - for a 20 mm screw pitch

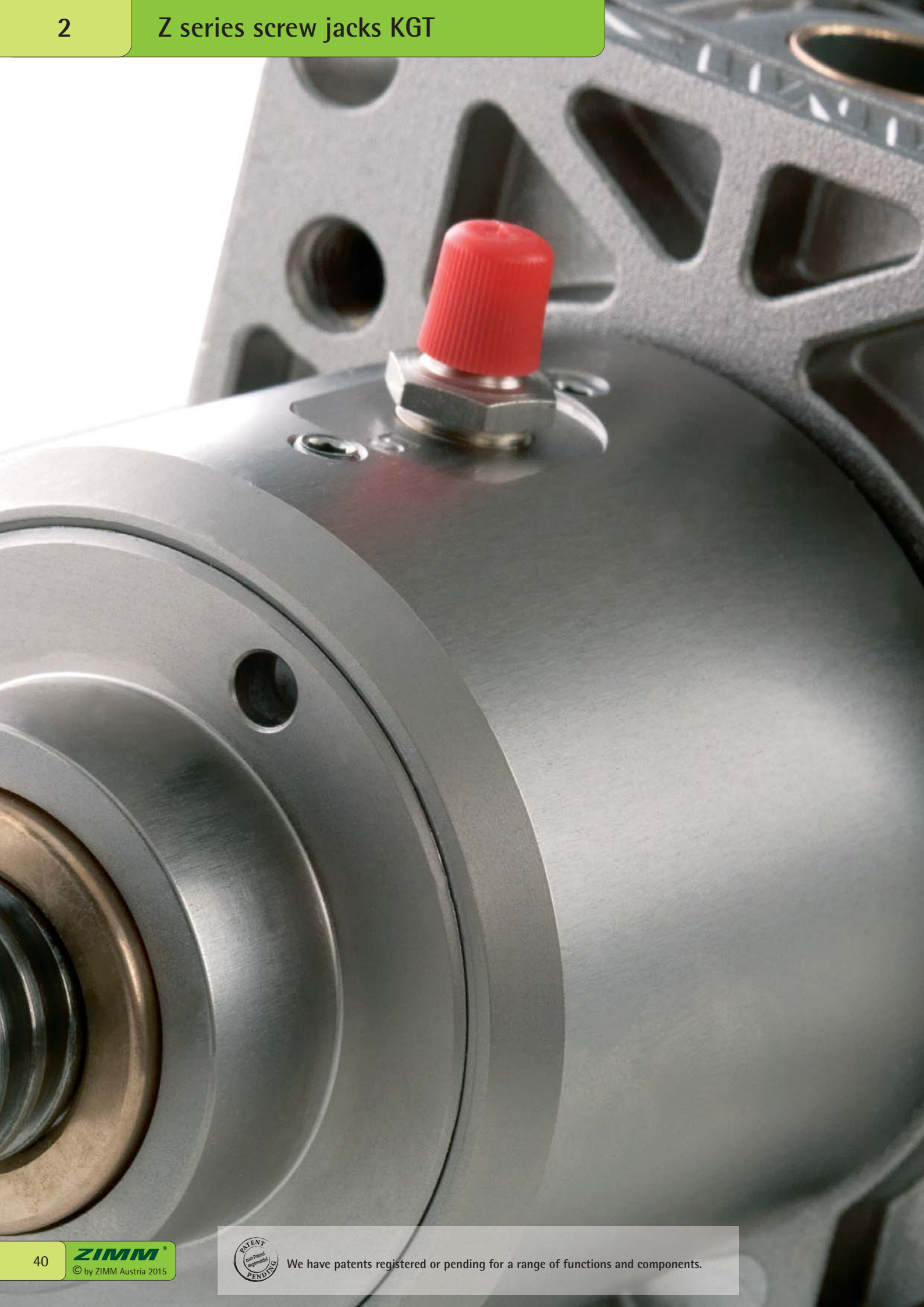

Ball screw KGT



Most screw jacks use trapezoidal screws Tr, because they are simple, robust and inexpensive. The proportion of screw jacks that use ball screws is however constantly increasing. The reasons for this are primarily their pitch accuracy, their high efficiency (less power consumption and less heat generation) and the higher pitches available, which permit higher stroke speeds.

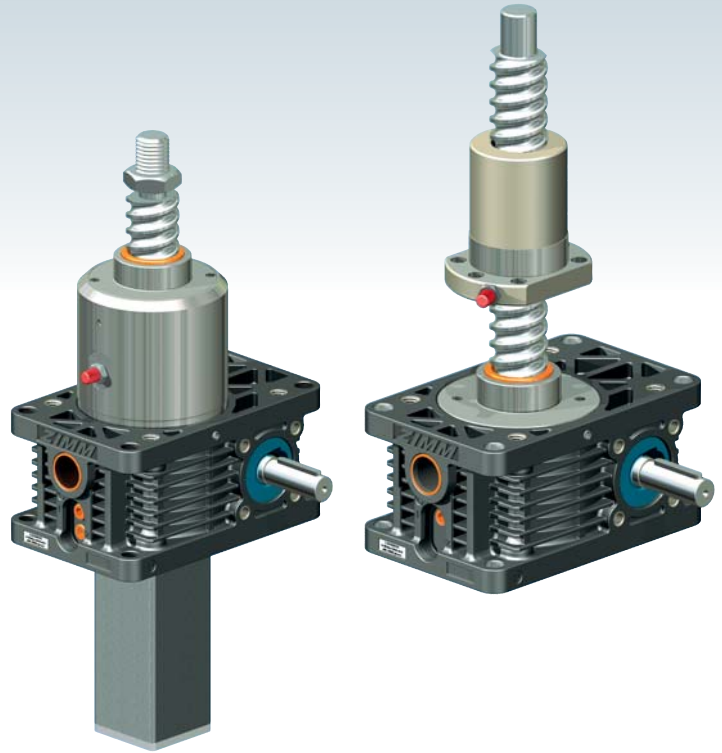

Technical data KGT

Pitch accuracy

0.05 mm / 300 mm

Material: 1.1213 (Cf 53), induction hardened and polished.

No self-locking!

Because of the lack of friction, a holding brake is necessary: a motor brake or a spring pressure brake is required.

Temperatures, duty cycle

Operating temperature range -20°C to +80°C (when <10° or >40°C please contact us).

The duty cycle can be up to 4 times higher than for trapezoidal screws (see diagrams), and at long strokes up to 2 times higher than for trapezoidal screws.

Service life

Heavy loads reduce the service life of the KGT. Tell us the load and stroke speed and we will calculate the service life.

Contamination

All nuts are fitted with scrapers. For heavy contamination and fine dust/chips, we recommend fitting bellows or a spiral spring cover.

Escape/rotation protection

Under no circumstances may the nut be screwed off the screw. We therefore always provide escape/rotation protection on the S version.

Start ramp / braking ramp

We recommend using a frequency converter or a servomotor, especially for high lead screw jacks. This allows regulation of the start ramp / braking ramp. This ensures protection for the entire system.

Safety clearance L3 can also be reduced at your own discretion, in particular for high pitches.

Grease nipples

The standard position of the grease nipple on the S version is on the gearbox face "C". Optionally, face A is available. Faces B and D are available on request.





UNIQUE:
Ball screw lubrication
for the S version

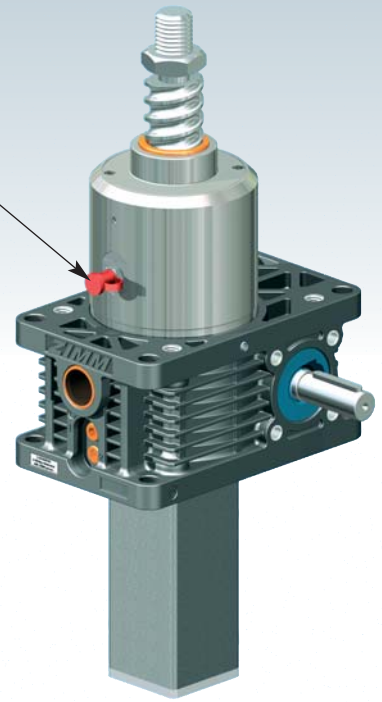

Z-5 to Z-25, KGT-S translating screw

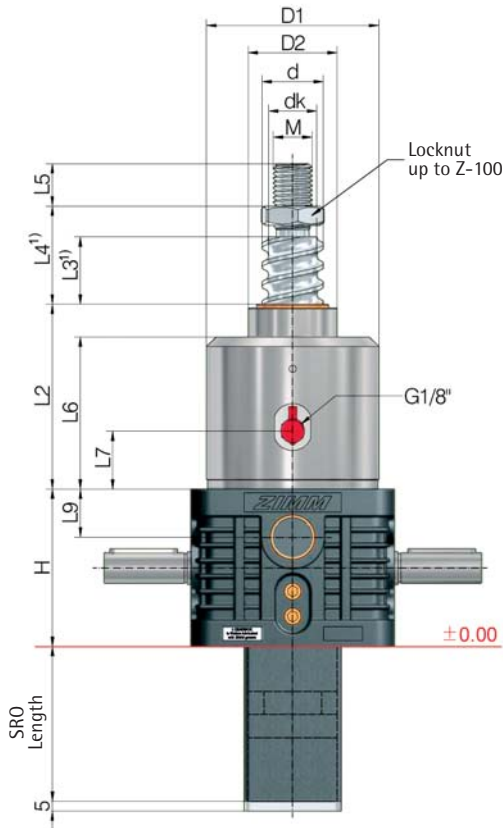

i - further technical information: Page 41
 - see the respective screw jack page for all other dimensions
 - see Section 4 for accessories
 - dimensions on the illustrative diagrams are in mm.
 We reserve the right to make changes.

🛒 Ordering example:
Z-25-SN-KGT 32x10, C = 33.4 kN
 dynamic load rating C

Screw jacks	Ball screw KGT	Stroke per drive revolution [mm]		KGT load rating [kN]		Dimensions [mm]												Axial play max ⁵⁾ [mm]	
		SN	SL	dyn. C ²⁾	stat. C ₀ =C _{0a}	H	d	d _k	D ₁	D ₂	L ₂	L ₃ ¹⁾	L ₄ ¹⁾	L ₅	L ₆	L ₇	L ₉		M
Z-5	16x5	1.25	0.31	9.3	13.1	62	15.5	12.9	59	29	66	15	25	19	54	23	18	M12	0.08
	16x10	2.50	0.63	15.4	26.5	62	15.4	13.0	59	29	66	25	35	19	54	23	18	M12	0.08
Z-10	25x5	1.25	0.31	12.3	22.5	74	24.5	21.9	69	39	85	15	27	20	69	21	21	M14	0.08
	25x10	2.50	0.63	13.2	25.3	74	24.5	21.9	69	39	85	25	37	20	69	21	21	M14	0.08
	25x25	6.25	1.56	16.7	32.2	74	24.5	22.0	69	39	85	60	72	20	69	21	21	M14	0.08
	25x50	12.50	3.13	15.4	31.7	74	24.1	21.5	69	39	85	125	137	20	69	21	21	M14	0.15
Z-25	32x5	0.83	0.21	21.5	49.3	82	31.5	28.9	89	46	99	15	31	22	82	33	25	M20	0.08
	32x10	1.67	0.42	33.4	54.5	82	32.7	27.3	89	46	99	20	36	22	82	33	25	M20	0.08
	32x20	3.33	0.83	29.7	59.8	82	31.7	27.9	89	46	99	35	51	22	82	33	25	M20	0.08
	32x40	6.67	1.67	14.9	32.4	82	30.9	28.3	89	46	99	70	86	22	82	33	25	M20	0.08

¹⁾ Depending on the control system and drive, the dimensions L₃ and L₄ can be reduced at your own discretion, in particular for high pitches.
 An extension may be required if a bellows or spiral spring extension is fitted
²⁾ Dynamic load rating to DIN 69051 part 4 draft 1989

⁵⁾ Reduced play 0.02 mm available on request



Z-5 to Z-25, KGT-R rotating screw

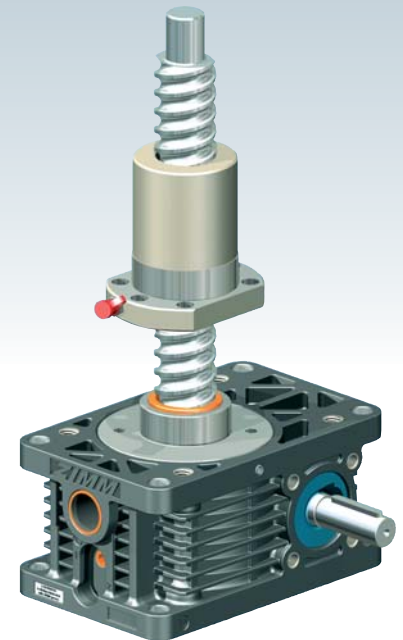

2

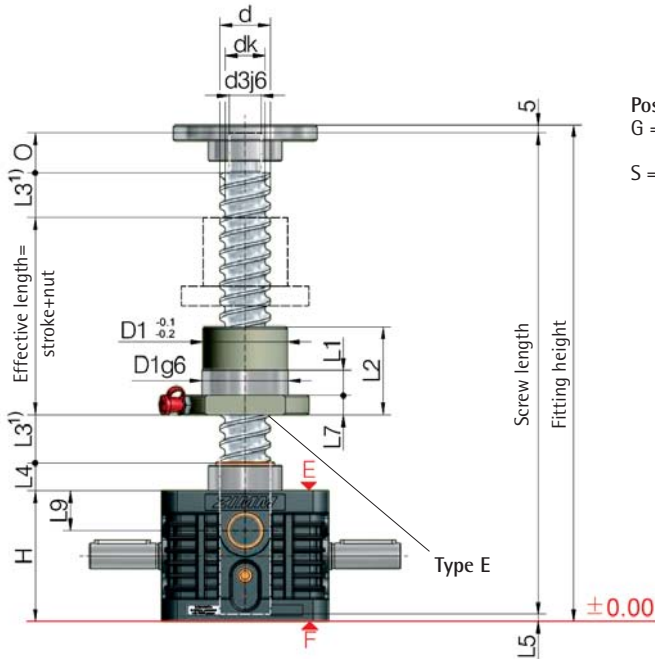

Position of the flanged nut:
G = flange gearbox side (as shown)
S = flange screw side

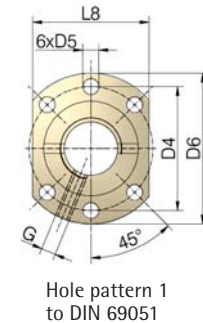
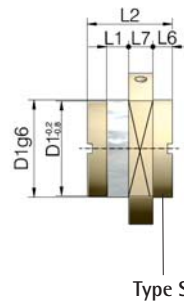

Hole pattern 1 to DIN 69051

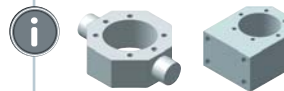

Adapter for KGT
Dimension sheet on request
(up to KGT Ø50)

- further technical information: Page 41
 - see the respective screw jack page for all other dimensions
 - see Section 4 for accessories
 - dimensions on the illustrative diagrams are in mm.
- We reserve the right to make changes.

Ordering example:

Z-25-RN-KGT 32x10, C = 33.4 kN - G

dynamic load rating C
Nut flange
G: flange gearbox side
S: flange screw side

Screw jacks	Ball screw KGT	Stroke per drive revolution [mm]		KGT load rating [kN]		Nut Type	Hole pattern	Dimensions [mm]															Lubrication hole	Axial play max ⁵⁾ [mm]			
		RN	RL	dyn. C ²⁾	stat. C ₀ =C _{0a}			d	dk	d ₃	O	H	D ₁	D ₄	D ₅	D ₆	L ₁	L ₂	L ₃ ¹⁾	L ₄	L ₅	L ₆			L ₇	L ₈	L ₉
Z-5	16x5	1.25	0.31	9.3	13.1	E	1	15.5	12.9	12	15	62	28	38	5.5	48	10	42	15	12	8	-	10	40	18	M6	0.08
	16x10	2.50	0.63	15.4	26.5	E	1	15.4	13.0	12	15	62	28	38	5.5	48	10	55	25	12	8	-	10	40	18	M6	0.08
Z-10	25x5	1.25	0.31	12.3	22.5	E	1	24.5	21.9	15	20	74	40	51	6.6	62	10	42	15	16	8	-	10	48	21	M6	0.08
	25x10	2.50	0.63	13.2	25.3	E	1	24.5	21.9	15	20	74	40	51	6.6	62	16	55	25	16	8	-	10	48	21	M6	0.08
	25x25 ³⁾	6.25	1.56	16.7	32.2	S	1	24.5	22.0	15	20	74	40	51	6.6	62	9	35	60	16	8	8	10	- ³⁾	21	M6	0.08
Z-25	25x50	12.50	3.14	15.4	31.7	S	1	24.1	21.5	15	20	74	40	51	6.6	62	10	58	125	16	8	10	10	48	21	M6	0.15
	32x5	0.83	0.21	21.5	49.3	E	1	31.5	28.9	20	25	82	50	65	9.0	80	10	55	15	17	5	-	12	62	25	M6	0.08
	32x10	1.67	0.42	33.4	54.5	E	1	32.7	27.3	20	25	82	53 ⁶⁾	65	9.0	80	16	69	20	17	5	-	12	62	25	M8x1	0.08
	32x20	3.33	0.83	29.7	59.8	E	1	31.7	27.9	20	25	82	53 ⁶⁾	65	9.0	80	16	80	35	17	5	-	12	62	25	M6	0.08
	32x40 ³⁾	6.67	1.67	14.9	32.4	S	N ⁴⁾	30.9	28.3	20	25	82	53 ⁶⁾	68 ⁶⁾	7.0 ⁶⁾	80	14	45	70	17	5	7.5	16	- ³⁾	25	M6	0.08

An increased screw (such as: Z-10-RN with screw 32x10) can also be used for the rotating version.

¹⁾ An extension may be required if a bellows or spiral spring is fitted
²⁾ Dynamic load rating to DIN 69051 part 4 draft 1989
³⁾ Round flange
⁴⁾ Hole pattern on request
⁵⁾ Reduced play 0.02 mm available on request

⁶⁾ Not to DIN 69051



UNIQUE:
Ball screw lubrication
for the S version

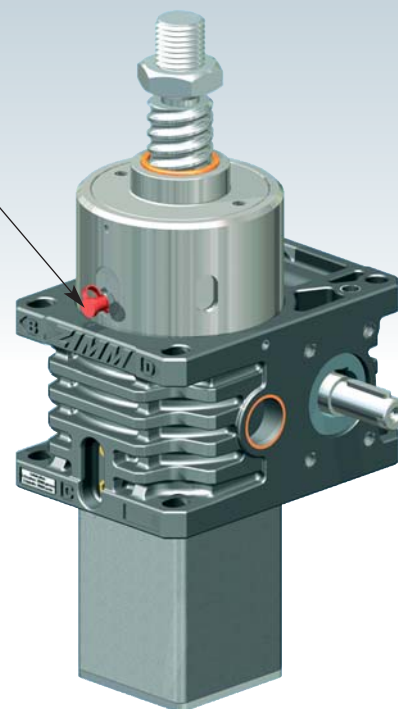

Z-50 to Z-150, KGT-S translating screw

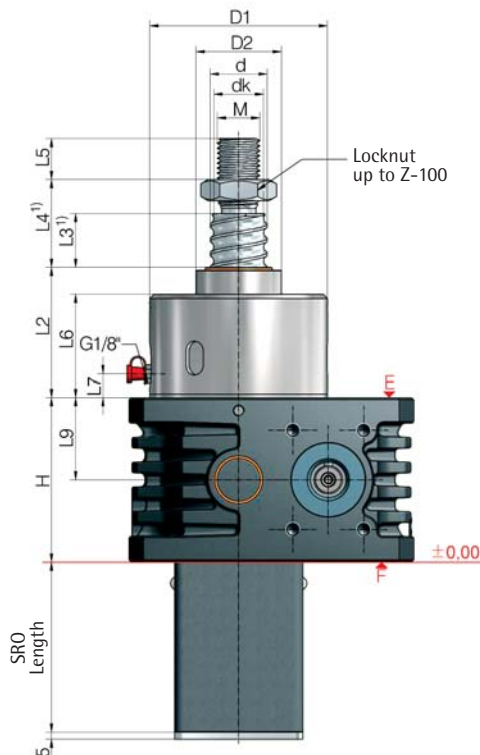

i - further technical information: Page 41
 - see the respective screw jack page for all other dimensions
 - see Section 4 for accessories
 - dimensions on the illustrative diagrams are in mm.
 We reserve the right to make changes.

Shopping cart icon **Ordering example:**
 Z-100-SN-KGT 50x20, C = 112.4 kN
 dynamic load rating C

Screw jacks	Ball screw KGT	Stroke per drive revolution [mm]		KGT load rating [kN]		Dimensions [mm]													Axial play max ⁵⁾ [mm]
		SN	SL	dyn. C ²⁾	stat. C ₀ =C _{0a}	H	d	dk	D ₁	D ₂	L ₂	L ₃ ¹⁾	L ₄ ¹⁾	L ₅	L ₆	L ₇	L ₉	M	
Z-50	40x5	0.71	0.18	23.8	63.1	116	39.5	36.9	125	60	93	15	39	29	74	17	58	M30	0.08
	40x10	1.43	0.36	38	69.1	116	39.5	34.1	125	60	93	15	39	29	74	17	58	M30	0.08
	40x20	2.86	0.72	33.3	76.1	116	39.7	35.9	125	60	93	30	54	29	74	17	58	M30	0.08
Z-100	40x40	5.71	1.43	35	101.9	116	38.9	36.3	125	60	93	60	84	29	74	17	58	M30	0.08
	50x10	1.11	0.28	68.7	155.8	160	49.5	44.1	148	85	112	20	48	48	82	19	80	M36	0.08
	50x20	2.22	0.56	60	136.3	160	49.5	44.1	148	85	112	40	68	48	82	19	80	M36	0.08
	50x10	1.11	0.28	112.1	338.5	160	50	43.6	148	85	148	20	48	48	118	19	80	M36	0.03
	50x20	2.22	0.56	112.4	214.7	160	50	41.1	148	85	148	40	68	48	118	19	80	M36	0.03
Z-150	50x40	4.44	1.11	84.7	143.1	160	50	41.1	148	85	148	80	108	48	118	19	80	M36	0.03
	63x10	1.11	0.28	150.2	598.4	185	63	56.6	168	90	150	20	48	48	118	24	92.5	M42x2	0.03
	63x20	2.22	0.56	173.5 ⁷⁾	346.2	185	63	51.8	168	90	150	40	40	48	118	24	92.5	M42x2	0.03
	63x40	4.44	1.11	96.6	205.1	185	63	54.1	168	90	150	80	80	48	118	24	92.5	M42x2	0.03
	63x60 ⁴⁾	6.67	1.67	59.5	102.5	185	63	54.1	168	90	150	120	120	48	118	24	92.5	M42x2	0.03

¹⁾ Depending on the control system and drive, the dimensions L₃ and L₄ can be reduced at your own discretion, in particular for high pitches. An extension may be required if a bellows or spiral spring is fitted.

²⁾ Dynamic load rating to DIN 69051 part 4 draft 1989

⁴⁾ Non-preferred design

⁵⁾ Reduced play 0.02 mm available on request

⁷⁾ Service life calculation with C_{dyn} 159 kN (gearbox bearing)

Ball screw
KGT



Z-35 to Z-150, KGT-R rotating ball screw

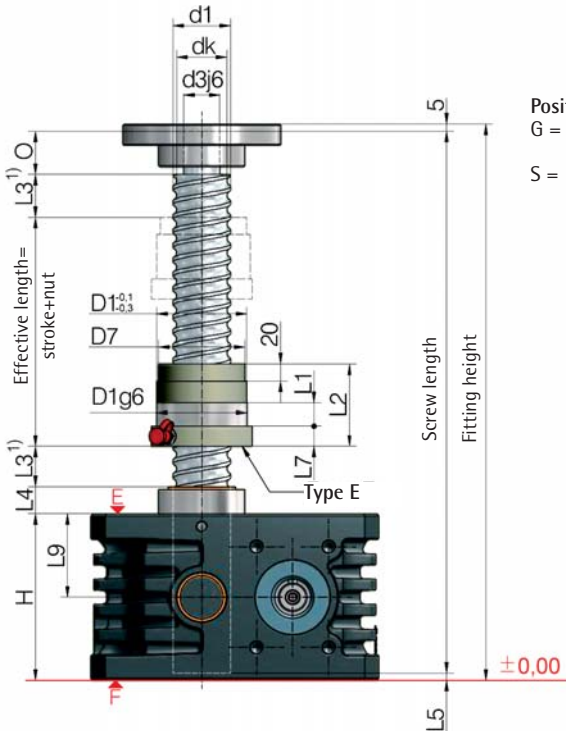

Position of the flanged nut:
G = flange gearbox side (as shown)
S = flange screw side

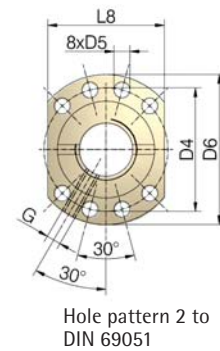
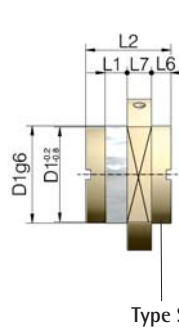

Hole pattern 2 to DIN 69051

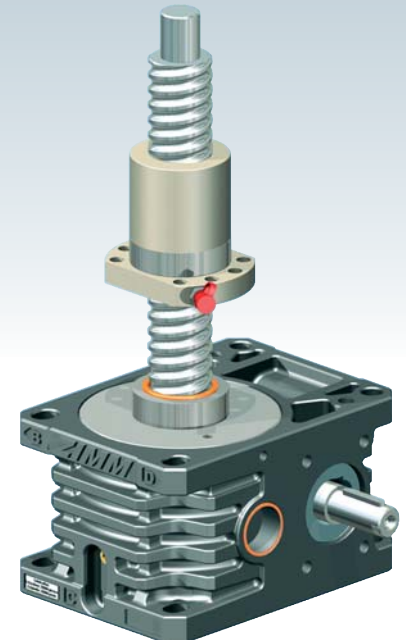

- further technical information: Page 41
- see the respective screw jack page for all other dimensions
- see Section 4 for accessories
- dimensions on the illustrative diagrams are in mm. We reserve the right to make changes.

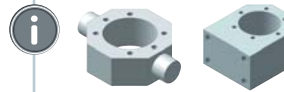

Adapter for KGT
Dimension sheet on request (up to KGT Ø50)



Ordering example:

Z-100-RN-KGT 50x20, C = 112.4 kN - G

dynamic load rating C

Nut flange

G: flange gearbox side

S: flange screw side

Screw jacks	Ball screw KGT ØxP	Stroke per drive revolution [mm]		KGT load rating [kN]		Nut Type Hole pattern	Dimensions [mm]																				Lubrication hole G	Axial play max ⁵⁾ [mm]
		RN	RL	dyn. C ²⁾	stat. C ₀ =C _{0a}		d	d _k	d ₃	O	H	D ₁	D ₄	D ₅	D ₆	D ₇	L ₁	L ₂	L ₃ ¹⁾	L ₄	L ₅	L ₆	L ₇	L ₈	L ₉			
Z-35	40x5	0.71	0.18	23.8	63.1	E 2	39.5	36.9	25	30	100	63	78	9	93	-	10	57	15	19	7	-	14	70	50 ⁷⁾	M6	0.08	
	40x10	1.43	0.36	38	69.1	E 2	39.5	34.1	25	30	100	63	78	9	93	-	16	71	15	19	7	-	14	70	50 ⁷⁾	M8x1	0.08	
	40x20	2.86	0.72	33.3	76.1	E 2	39.7	35.9	25	30	100	63	78	9	93	-	16	80	30	19	7	-	14	70	50 ⁷⁾	M8x1	0.08	
	40x40 ³⁾	5.71	1.43	35	101.9	S 2	38.9	36.3	25	30	100	63	78	9	93	-	16	85	60	19	7	7.5	14	- ³⁾	50 ⁷⁾	M8x1	0.08	
Z-50	40x5	0.71	0.18	23.8	63.1	E 2	39.5	36.9	25	30	116	63	78	9	93	-	10	57	15	19	7	-	14	70	58 ⁷⁾	M6	0.08	
	40x10	1.43	0.36	38	69.1	E 2	39.5	34.1	25	30	116	63	78	9	93	-	16	71	15	19	7	-	14	70	58 ⁷⁾	M8x1	0.08	
	40x20	2.86	0.72	33.3	76.1	E 2	39.7	35.9	25	30	116	63	78	9	93	-	16	80	30	19	7	-	14	70	58 ⁷⁾	M8x1	0.08	
	40x40 ³⁾	5.71	1.43	35	101.9	S 2	38.9	36.3	25	30	116	63	78	9	93	-	16	85	60	19	7	7.5	14	- ³⁾	58 ⁷⁾	M8x1	0.08	
Z-100	50x10	1.11	0.28	68.7	155.8	E 2	49.5	44.1	40	45	160	75	93	11	110	-	16	95	20	30	8	-	16	85	80	M8x1	0.08	
	50x20	2.22	0.56	60	136.3	E 2	49.5	44.1	40	45	160	85 ⁶⁾	103 ⁶⁾	11	125 ⁶⁾	-	22	95	40	30	8	-	18	95	80	M8x1	0.08	
	50x10	1.11	0.28	112.1	338.5	E 2	50	43.6	40	45	160	75	93	11	110	-	16	107	20	30	8	-	16	85	80	M8x1	0.03	
	50x20	2.22	0.56	112.4	214.7	E 2	50	41.1	40	45	160	85 ⁶⁾	103 ⁶⁾	11	120 ⁶⁾	-	16	125	40	30	8	-	16	95	80	M8x1	0.03	
	50x40	4.44	1.11	84.7	143.1	E 2	50	41.1	40	45	160	85 ⁶⁾	103 ⁶⁾	11	120 ⁶⁾	-	16	125	80	30	8	-	16	95	80	M8x1	0.03	
Z-150	50x50 ⁴⁾	5.56	1.39	84.7	143.1	E 2	50	41.1	40	45	160	85 ⁶⁾	103 ⁶⁾	11	120 ⁶⁾	-	16	145	100	30	8	-	16	95	80	M8x1	0.03	
	63x10 ⁸⁾	1.11	0.28	84.7	210.8	E 2	63	58.8	45	55	185	90	108	11	125	-	16	120	20	32	7	-	18	95	92.5 ⁷⁾	M8x1	0.05	
	63x20 ⁸⁾	2.22	0.56	230 ⁷⁾	600	E 2	63	50.2	45	55	185	125 ⁶⁾	145 ⁶⁾	13.5	165 ⁶⁾	-	25	170	40	32	7	-	25	130	92.5 ⁷⁾	M8x1	0.05	
	63x10	1.11	0.28	150.2	598.4	E 2	63	56.6	45	55	185	90	108	11	125	-	16	135	20	32	7	-	18	95	92.5 ⁷⁾	M8x1	0.03	
	63x20	2.22	0.56	173.5 ⁷⁾	346.2	E 2	63	51.8	45	55	185	95	115	13.5	135	90	25	135	40	32	7	-	20	100	92.5 ⁷⁾	M8x1	0.03	
	63x40	4.44	1.11	96.6	205.1	E 2	63	54.1	45	55	185	95	115	13.5	135	90	25	126	80	32	7	-	20	100	92.5 ⁷⁾	M8x1	0.03	
63x60 ⁴⁾	6.67	1.67	59.5	102.5	E 2	63	54.1	45	55	185	95	115	13.5	135	90	25	126	120	32	7	-	20	100	92.5 ⁷⁾	M8x1	0.03		

¹⁾ An extension may be required if a bellows or spiral spring is fitted
²⁾ Dynamic load rating to DIN 69051 part 4 draft 1989
³⁾ Round flange
⁴⁾ Non-preferred design

⁵⁾ Reduced play 0.02 mm available on request
⁶⁾ Not to DIN 69051
⁷⁾ Service life calculation with C_{dyn} 159 kN (gearbox bearing)
⁸⁾ Design being superseded



UNIQUE:
Ball screw lubrication
for the S version

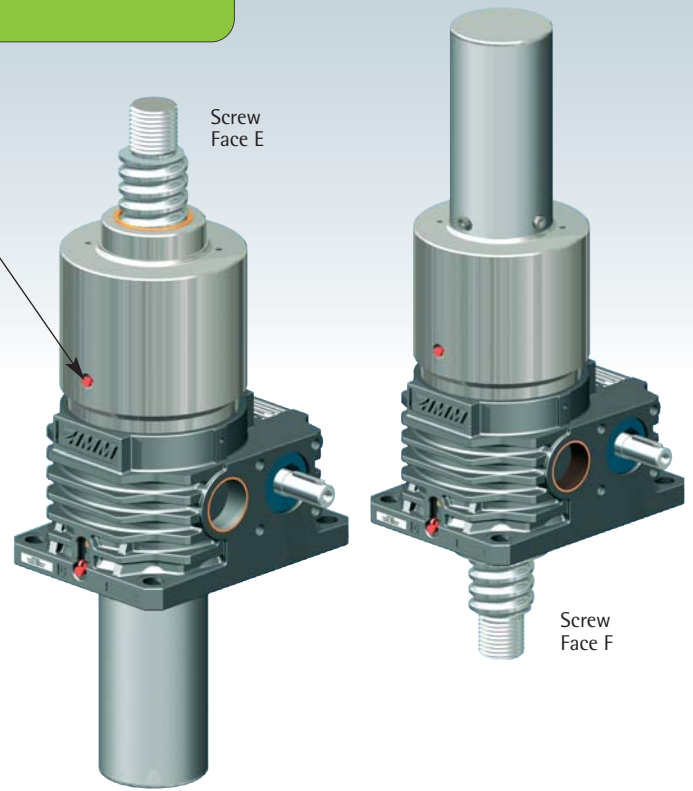

Z-250 and Z-350, KGT-S
Translating screw

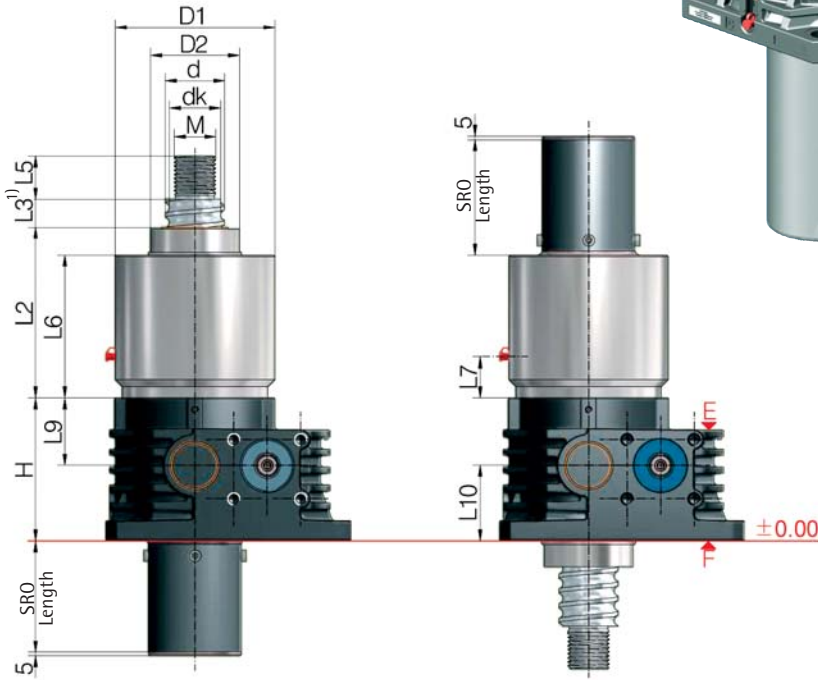

i - further technical information: Page 41
 - see the respective screw jack page for all other dimensions
 - see Section 4 for accessories
 - dimensions on the illustrative diagrams are in mm.
 We reserve the right to make changes.

Shopping cart icon **Ordering example:**
Z-250-SN-E-KGT 80x40, C = 251.2 kN
 Screw face E or F
 dynamic load rating C

Screw jacks	Ball screw KGT ØxP	Stroke per drive revolution [mm]		KGT load rating [kN]		Dimensions [mm]													Axial play max. [mm]
		SN	SL	dyn. C ²⁾	stat. C ₀ =C _{0a}	H	d	dk	D ₁	D ₂	L ₂	L ₃ ¹⁾	L ₅	L ₆	L ₇	L ₉	L ₁₀	M	
Z-250	80x10 ⁴⁾	0.94	0.31	193.0	993.4	193	80	73.6	216	120	228	20	58	191	45	91	102	M56x2	0.03
	80x20	1.87	0.63	359.2	942.5	193	80	67	216	120	228	40	58	191	45	91	102	M56x2	0.03
	80x40	3.75	1.25	251.2	565.5	193	80	67	216	120	228	80	58	191	45	91	102	M56x2	0.03
	80x60	5.62	1.88	189.1	377.0	193	80	67	216	120	228	120	58	191	45	91	102	M56x2	0.03
Z-350	100x20	1.87	0.63	330.2	979.1	230	100	87.4	275	145	223	40	78	199	54	115	115	M72x3	0.03
	100x40	3.75	1.25	270.0	734.0	230	100	87.4	275	145	223	80	78	199	54	115	115	M72x3	0.03
	100x60	5.62	1.88	203.0	489.6	230	100	87.4	275	145	223	120	78	199	54	115	115	M72x3	0.03
	100x80 ⁴⁾	7.50	2.50	203.0	489.6	230	100	87.4	275	145	263	160	78	239	54	115	115	M72x3	0.03

¹⁾ Depending on the control system and drive, the dimension L₃ can be reduced at your own discretion. An extension may be required if a bellows or spiral spring is fitted

²⁾ Dynamic load rating to DIN 69051 part 4 draft 1989

⁴⁾ Non-preferred design



Z-250 and Z-350, KGT-R
Rotating screw

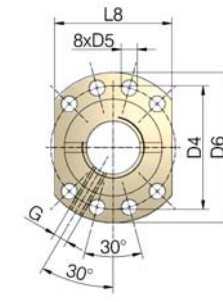
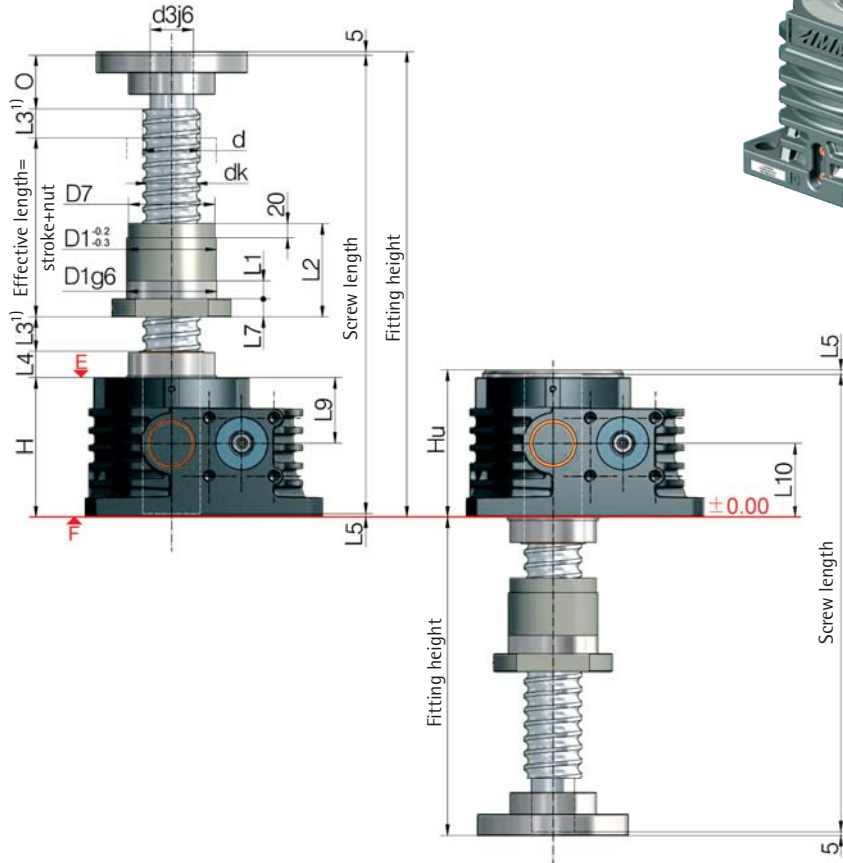

Hole pattern 2 to DIN 69051

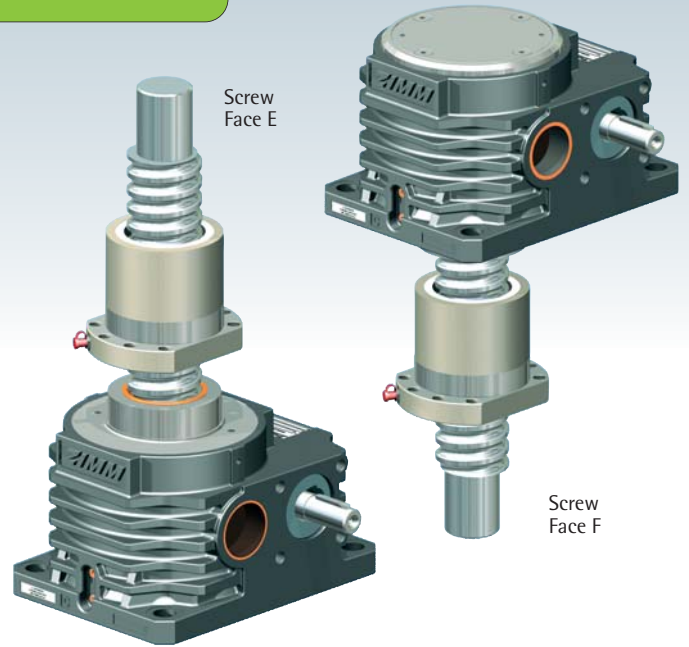

i - further technical information: Page 41
 - see the respective screw jack page for all other dimensions
 - see Section 4 for accessories
 - dimensions on the illustrative diagrams are in mm.
 We reserve the right to make changes.

Ordering example:
Z-250-RN-E-KGT 80x40, C = 112.4 kN - G
 Screw face E or F
 dynamic load rating C
 Nut flange
 G: flange gearbox side
 S: flange screw side

Screw jacks	Ball screw KGT	Stroke per drive revolution [mm]		KGT load rating [kN]		Nut Type	Nut Hole pattern	Dimensions [mm]																Lubri-cation hole G	Axial play max [mm]				
		RN	RL	dyn. stat. C ²⁾	C ₀ =C _{0a}			d	d _k	d _s	O	H	H _u	D ₁	D ₄	D ₅	D ₆	D ₇	L ₁	L ₂	L ₃	L ₄	L ₅			L ₇	L ₈	L ₉	L ₁₀
Z-250	80x10 ⁴⁾	0.94	0.31	93.4	269.2	E 2	2	80	75.8	60	75	193	204	105	125	13.5	145	-	16	120	20	37	5	20	110	91	102	M8x1	0.05
	80x20 ⁴⁾	1.87	0.63	320.0	820.0	E 2	2	78	68.2	60	75	193	204	135	155	13.5	175	-	25	190	40	37	5	25	140	91	102	M8x1	0.05
	80x10 ⁴⁾	0.94	0.31	193.0	993.4	E 2	2	80	73.6	60	75	193	204	105	125	13.5	145	-	16	160	20	37	5	20	110	91	102	M8x1	0.03
	80x20	1.87	0.63	359.2	942.5	E 2	2	80	67	60	75	193	204	125	145	13.5	165	120	25	190	40	37	5	25	130	91	102	M8x1	0.03
	80x40	3.75	1.25	251.2	565.5	E 2	2	80	67	60	75	193	204	125	145	13.5	165	120	25	190	80	37	5	25	130	91	102	M8x1	0.03
	80x60	5.62	1.88	189.1	377.0	E 2	2	80	67	60	75	193	204	125	145	13.5	165	120	25	190	120	37	5	25	130	91	102	M8x1	0.03
Z-350	100x20	1.87	0.63	330.2	979.1	E 2	2	100	87.4	80	100	230	230	150	176	17.5	202	145	25	175	40	24	6	30	155	115	115	M8x1	0.03
	100x40	3.75	1.25	270.0	734.0	E 2	2	100	87.4	80	100	230	230	150	176	17.5	202	145	25	175	80	24	6	30	155	115	115	M8x1	0.03
	100x60	5.62	1.88	203.0	489.6	E 2	2	100	87.4	80	100	230	230	150	176	17.5	202	145	25	175	120	24	6	30	155	115	115	M8x1	0.03
	100x80	7.50	2.50	203.0	489.6	E 2	2	100	87.4	80	100	230	230	150	176	17.5	202	145	25	215	160	24	6	30	155	115	115	M8x1	0.03

¹⁾ An extension may be required if a bellows or spiral spring is fitted
²⁾ Dynamic load rating to DIN 69051 part 4 draft 1989

⁴⁾ Non-preferred design



UNIQUE:
Ball screw lubrication for
the S version

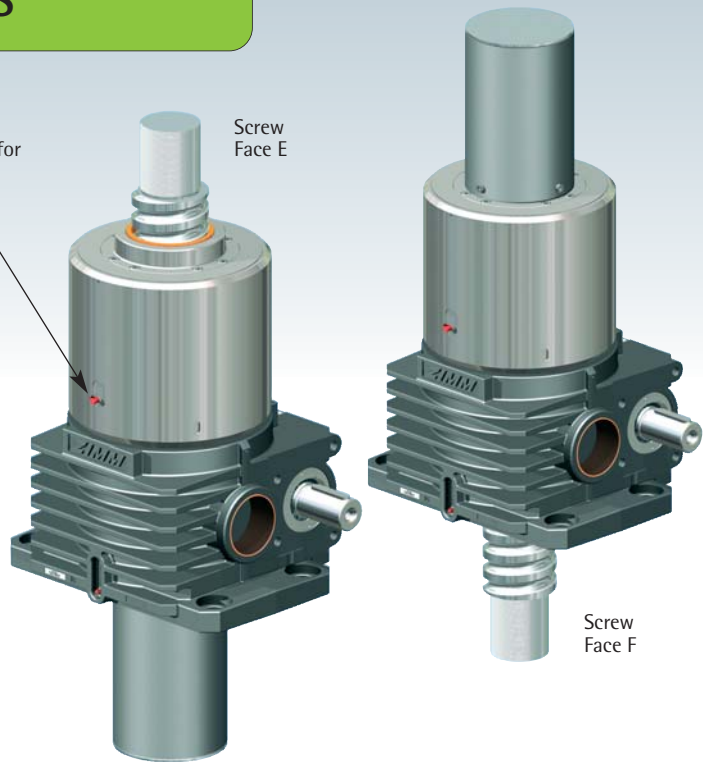

Z-500 to Z-1000, KGT-S
Translating screw

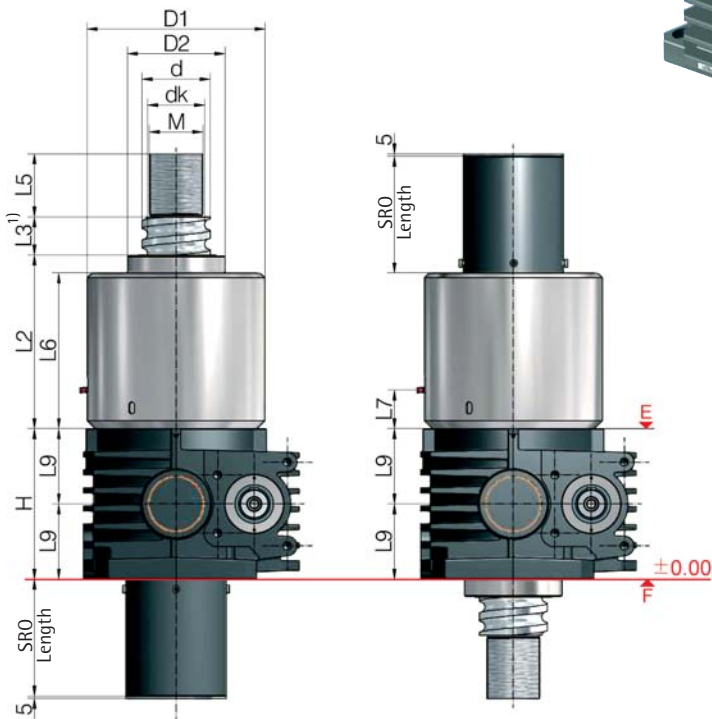

- further technical information: Page 41
- see the respective screw jack page for all other dimensions
- see Section 4 for accessories
- dimensions on the illustrative diagrams are in mm.
- We reserve the right to make changes.

Ordering example:

Z-1000-SN-E-KGT 160x40, C = 1069.9 kN

Screw face E or F
dynamic load rating C

Screw jacks	Ball screw KGT	Stroke per drive revolution [mm]		KGT load rating [kN]		Dimensions [mm]											Axial play max. [mm]	
		SN	SL	dyn. C ²⁾	stat. C ₀ =C _{0a}	H	d	dk	D ₁	D ₂	L ₂	L ₃ ¹⁾	L ₅	L ₆	L ₇	L ₉		M
Z-500	125x25	2.34	0.78	575.1	1863	260	125	107.8	315	170	283	50	118	251	55	130	M100x3	0.03
	125x40	3.75	1.25	402.2	1117	260	125	107.8	315	170	283	80	118	251	55	130	M100x3	0.03
	125x60	5.62	1.88	302.8	745.3	260	125	107.8	315	170	283	120	118	251	55	130	M100x3	0.03
	125x80	7.50	2.50	218.7	630.5	260	125	112.4	315	170	283	160	118	251	55	130	M100x3	0.03
Z-750	140x25	1.88	0.63	774.3	3082	310	140	122.8	365	200	374	50	130	337	84	155	M110x3	0.03
	140x40	3.00	1.00	754.0	2100	310	140	117	365	200	374	80	130	337	84	155	M110x3	0.03
	140x60	4.50	1.50	616.7	1575	310	140	117	365	200	374	120	130	337	84	155	M110x3	0.03
	140x80	6.00	2.00	464.3	1048	310	140	117	365	200	374	160	130	337	84	155	M110x3	0.03
Z-1000	160x25	1.88	0.63	884.7	4068	340	160	142.8	405	250	392	50	130	360	79	170	M110x3	0.03
	160x40	3.00	1.00	1069.9	3016	340	160	132.8	405	250	392	80	130	360	79	170	M110x3	0.03
	160x60	4.50	1.50	663.0	1923	340	160	137	405	250	392	120	130	360	79	170	M110x3	0.03
	160x80	6.00	2.00	499.1	1282	340	160	137	405	250	392	160	130	360	79	170	M110x3	0.03

¹⁾ Depending on the control system and drive, the dimension L₃ can be reduced at your own discretion. An extension may be required if a bellows or spiral spring is fitted

²⁾ Dynamic load rating to DIN 69051 part 4 draft 1989



Z-500 to Z-1000, KGT-R
Rotating screw

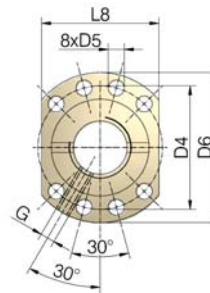
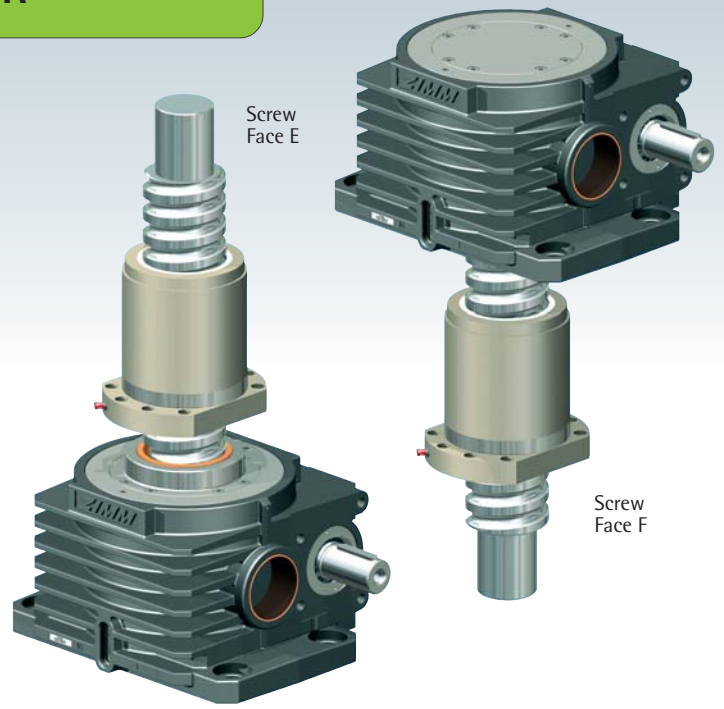
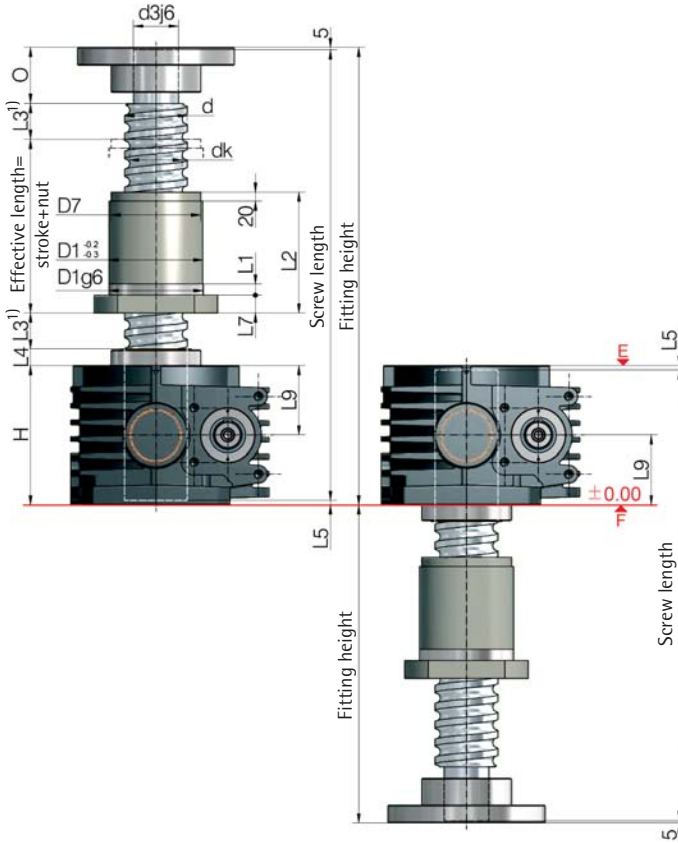

Hole pattern 2
to DIN 69051

- further technical information: Page 41
 - see the respective screw jack page for all other dimensions
 - see Section 4 for accessories
 - dimensions on the illustrative diagrams are in mm.
- We reserve the right to make changes

Ordering example:
Z-1000-RN-E-KGT 160x40, C = 1069.9 kN - G

Screw face E or F
 dynamic load rating C
 Nut flange
 G: flange gearbox side
 S: flange screw side

Screw jacks	Ball screw KGT	Stroke per drive revolution [mm]		KGT load rating [kN]		Nut Type	Hole pattern	Dimensions [mm]																Lubri-cation hole	Axial play max [mm]		
		RN	RL	dyn. C ²⁾	stat. C ₀ =C _{0a}			d	d _k	d ₃	O	H	D ₁	D ₄	D ₅	D ₆	D ₇	L ₁	L ₂	L ₃ ¹⁾	L ₄	L ₅	L ₇			L ₈	L ₉
Z-500	125x25	2.34	0.78	575.1	1863	E 2	2	125	107.8	95	120	260	185	212	17.5	240	170	25	250	50	32	6	30	190	130	M8x1	0.03
	125x40	3.75	1.25	402.2	1117	E 2	2	125	107.8	95	120	260	185	212	17.5	240	170	25	250	80	32	6	30	190	130	M8x1	0.03
	125x60	5.62	1.88	302.8	745.3	E 2	2	125	107.8	95	120	260	185	212	17.5	240	170	25	180	120	32	6	30	190	130	M8x1	0.03
	125x80	7.50	2.50	218.7	630.5	E 2	2	125	112.4	95	120	260	185	212	17.5	240	170	25	220	160	32	6	30	190	130	M8x1	0.03
Z-750	140x25	1.88	0.63	774.3	3082	E 2	2	140	122.8	100	120	310	210	243	22	275	200	25	310	50	37	10	40	215	115	M8x1	0.03
	140x40	3.00	1.00	754.0	2100	E 2	2	140	117	100	120	310	210	243	22	275	200	25	310	80	37	10	40	215	115	M8x1	0.03
	140x60	4.50	1.50	616.7	1575	E 2	2	140	117	100	120	310	225	260	22	295	200	25	280	120	37	10	40	230	115	M8x1	0.03
	140x80	6.00	2.00	464.3	1048	E 2	2	140	117	100	120	310	225	260	22	295	200	25	260	160	37	10	40	230	115	M8x1	0.03
Z-1000	160x25	1.88	0.63	884.7	4068	E 2	2	160	142.8	130	175	340	225	260	22	295	-	25	345	50	31	13	40	230	170	M8x1	0.03
	160x40	3.00	1.00	1069.9	3016	E 2	2	160	132.8	130	175	340	260	300	22	340	250	40	310	80	31	13	40	265	170	M8x1	0.03
	160x60	4.50	1.50	663.0	1923	E 2	2	160	137	130	175	340	260	300	22	340	250	40	295	120	31	13	40	265	170	M8x1	0.03
	160x80	6.00	2.00	499.1	1282	E 2	2	160	137	130	175	340	260	300	22	340	250	40	275	160	31	13	40	265	170	M8x1	0.03

¹⁾ An extension may be required if a bellows or spiral spring is fitted
²⁾ Dynamic load rating to DIN 69051 part 4 draft 1989



Safety nut SIFA



Function

A safety nut is designed for use where stripping and break up of the thread could cause a hazard to persons.

A safety nut can also provide protection for other equipment against the consequences of machine failures and downtimes.

Wear

Once the wear exceeds max. 25% of the screw pitch, the load nut (R) or the gearbox (S) must be replaced.

Monitoring

Wear and thread play should be checked and documented at regular intervals (depending on the duty cycle).

This allows the fitting of replacement parts to be planned ahead, reducing unscheduled system downtime.

Electrical monitoring

Electrical monitoring gives a signal when wear reaches approx. 25%. This signal can be displayed immediately at a central control point. Replacement of the worn parts can then be scheduled.

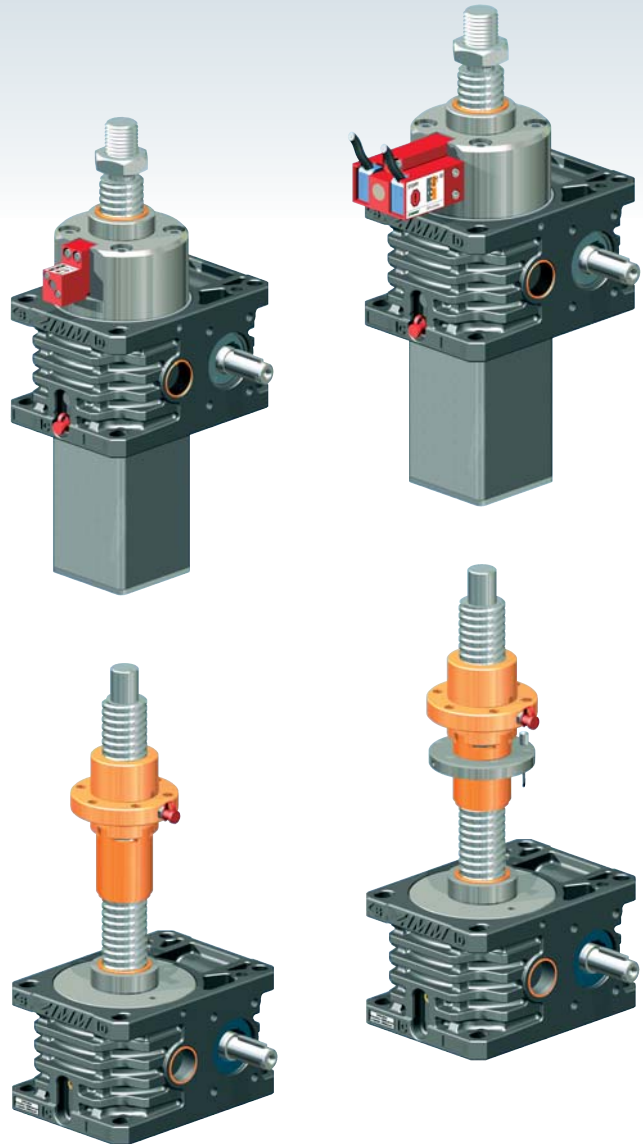

Screw jacks	Pitch P	max. permissible wear/ thread play* (25% of P)
[TrØxP]	[mm]	[mm]
Tr16x4, Tr18x4, Tr20x4	4	1.0
Tr30x6	6	1.5
Tr40x7	7	1.75
Tr50x8	8	2.0
Tr55x9, Tr60x9	9	2.25
Tr80x16, Tr100x16, Tr120x16	16	4.0
Tr140x20, Tr160x20	20	5.0

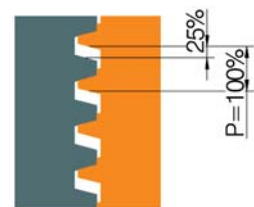

max. 25% wear

* Identical for double pitch screws (same thread flank thickness)



We have patents registered or pending for a range of functions and components.



SIFA-S translating screw

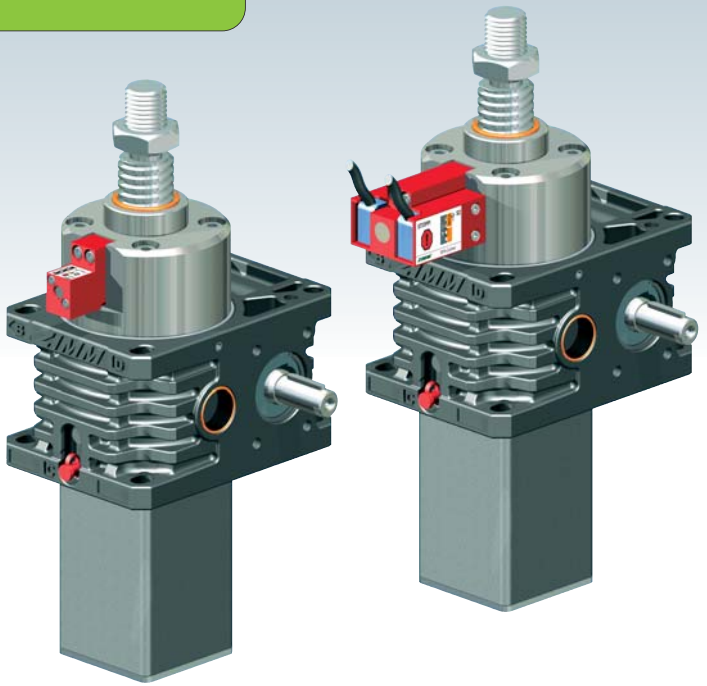
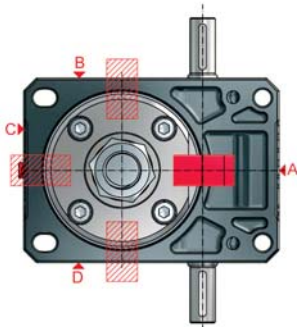
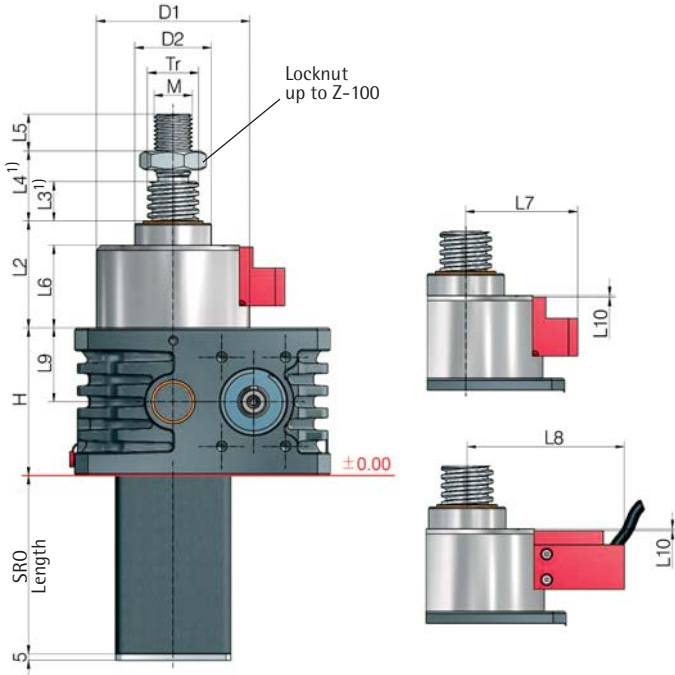

Function S version



The load is borne by the worm wheel via the screw. If the worm wheel screw thread wears through, the SIFA restrains the screw. The load remains supported.

Direction of loading, compressive and tensile
The new SIFA-S operates equally in both compressive and tensile directions of loading!

i further technical information: Page 51

Ordering code: Z-35-SN-SIFA-OP-A

Version
SN or SL

Monitoring
OP: visual
EL: electrical (wear, thread stripping)
ELV: only wear
ELD: only thread stripping
NO: without any monitoring

Position
A (standard), B, C or D
(can also subsequently be rotated steplessly through 360°)

Screw jacks	Stroke travel/rev.		Tr thread	H	D1	D2	L2	L3 ¹⁾	L4 ¹⁾	L5	L6	L7	L8	L9	L10	M
	SN	SL														
Z-10	1	0.25	20x4	74	81	39	74	10	22	20	58	72	108	21	1	M14
Z-25	1	0.25	30x6	82	92	46	76	10	26	22	59	79	114	25	1	M20
Z-35	1	0.25	40x7	100	100	60	80	10	34	29	61	82	117	50	1	M30
Z-50	1	0.25	40x7	116	120	60	84	10	34	29	65	88	123	58	1	M30
Z-100	1	0.25	55x9	160	135	85	103	20	48	48	73	95	130	80	9	M36
Z-150	1	0.25	60x9	185	161	90	113	20	20	48	81	107	141	92.5	6	M42x2
Z-250	1.5	0.50	80x16	193	210	120	169	20	20	58	137	117	152	91	13	M56x2
Z-350	1.5	0.50	100x16	230	-	145	174	20	20	78	155	-	-	115	-	M72x3

up to Z-1000 on request

¹⁾ See Section 8 for extension if bellows or spiral spring is fitted

SIFA-S, monitoring

Visual

Monitoring

Wear should be checked and documented at regular intervals. This allows the fitting operation for replacement to be planned in good time so as to avoid system downtime.

OK
Wear still <25% of P

CAUTION!
max. permissible wear reached –
Replace the gearbox

STOP!
Wear >25% or thread already worn through –
Stop operation immediately!

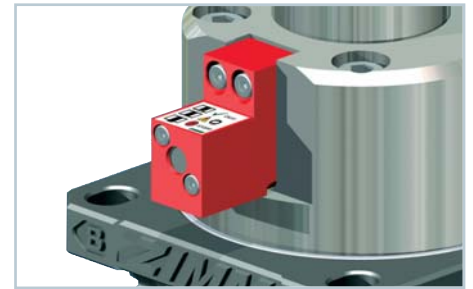
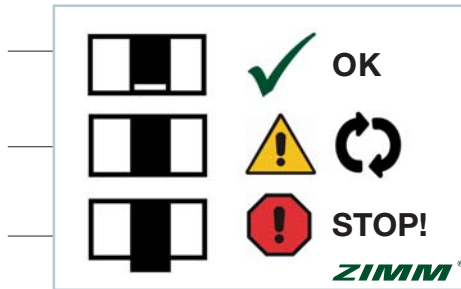

Electrical

WARNING! Switch S1
At 25% wear the limit switch S1 trips.
The customer must detect this signal.
This enables substitution to be planned well
in advance and therefore prevents any
unnecessary downtime.



STOP! Switch S2
If after the first signal operation of the jack
continues, the nut will continue to wear until
the thread is worn through. When the thread
is worn through, the safety nut takes the load.
The limit switch S2 trips.
The customer must detect this signal and
stop the system.

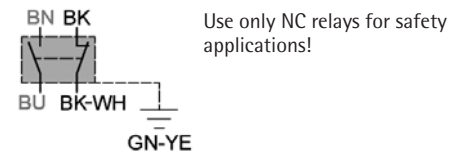
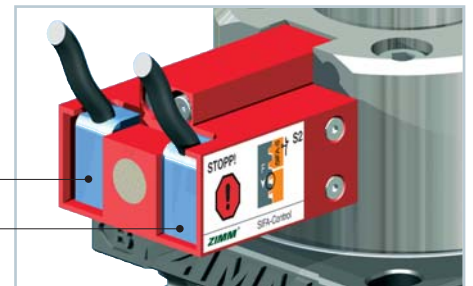

Without any monitoring

If the version used has no monitoring,
the dimension A must be measured and
documented when new, then regularly
checked and documented.

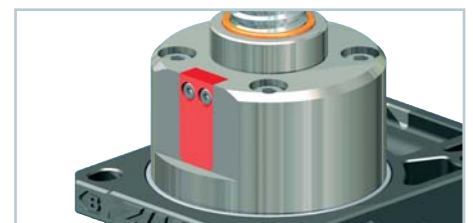
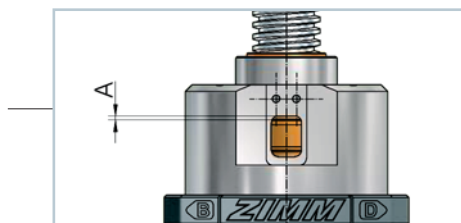



SIFA-R rotating screw

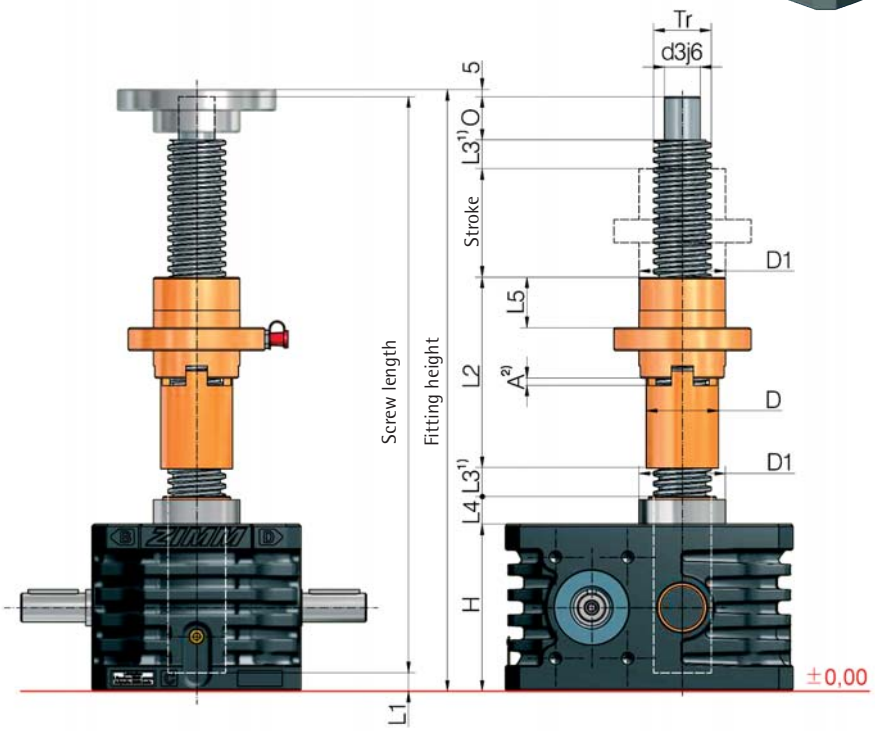
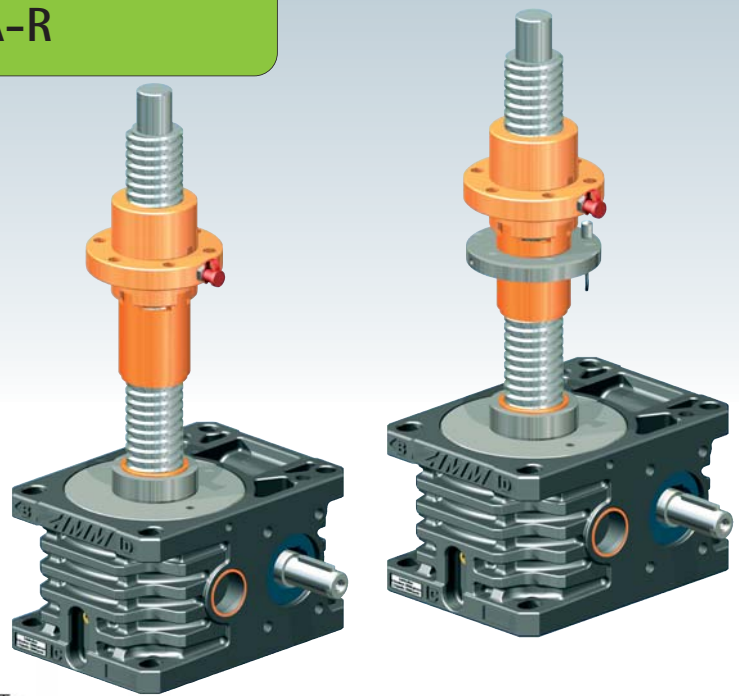

Function R version



The load is borne by the duplex nut. The safety nut runs alongside the duplex nut, bearing no load. If the nut thread is worn through due to wear, the SIFA takes the load.

Direction of loading, tensile or compressive
A drawing showing the direction of loading is necessary in order to ensure the safety function. The SIFA-R operates in only one direction of loading.

- further technical information: Page 51
- see the respective screw jack page for all other dimensions
- see Section 4 for accessories
- SIFA in combination with self-aligning nut PM available on request

Screw jacks	Tr thread	H	D1	D	d3j6	O	L1	L2	L3 ¹⁾	L4	L5	A ²⁾
Z-5	18x4	62	29	24	12	15	8	70	10	12	20	3
Z-10	20x4	74	39	28	15	20	8	84	10	16	20	3
Z-25	30x6	82	46	38	20	25	5	95	10	17	23	4
Z-35	40x7	100	60	50	25	30	7	133	10	19	36	4
Z-50	40x7	116	60	50	25	30	7	133	10	19	36	4
Z-100	55x9	160	85	65	40	45	8	173	20	30	54	6
Z-150	60x9	185	90	70	45	55	7	211	20	32	75	6
Z-250	80x16	193	120	100	60	75	5	250	20	37	85	9
Z-350	100x16	230	150	120	80	100	6	270	20	24	100	9
Z-500	120x16	260	170	135	95	120	6	303	40	32	110	9
Z-750	140x20	310	200	170	100	120	10	365	40	37	140	12
Z-1000	160x20	340	250	190	130	175	13	500	40	32	210	12

¹⁾ see Section 8 for extension if bellows or spiral spring is fitted
²⁾ approx. original setting, must be measured and documented by the customer, and referred to when checking

Make sure you fit it the right way up:

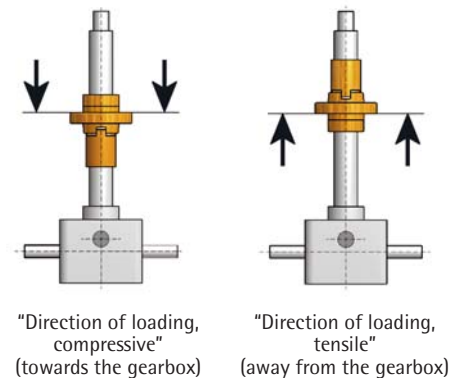

SIFA-R, monitoring

Visual

Dimension A is approx. the original setting. Dimension A must be measured and documented by the customer, and referred to when checking.

This enables substitution to be planned well in advance and therefore prevents any unnecessary downtime. When the thread is worn through, take the equipment out of service immediately.

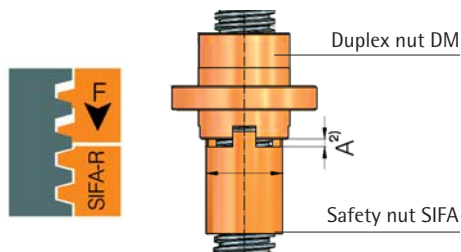

Electrical

The initiator must be set that it switches off when the load nut reaches 25% of the wear. This enables a replacement to be planned well in advance and therefore prevents any unnecessary downtime. When the thread is worn through, take the system out of service immediately.

