

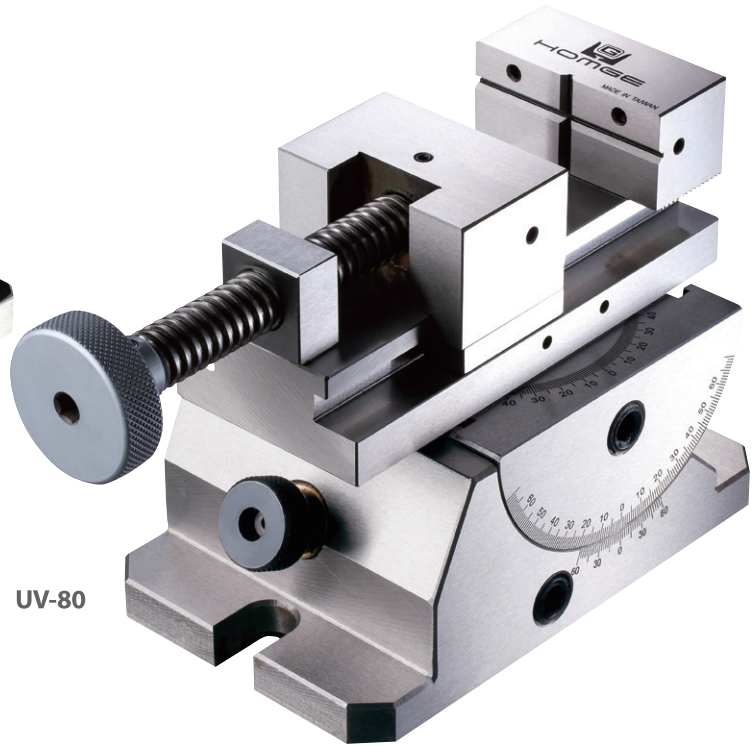

UV-120



UV-80

**STANDARD ACCESSORY:**

- 1 pc of Wrench

**PRECISION UNIVERSAL VISE**

**Model: UV-80, 120**

- Precision graduation for accurate reading
- Horizontal swivel through 360°
- Tilts 45° vertically
- Its swiveling and tilting features make this unit well suited for straight or inclined surface, angular drilling machining on various machine tools as precision grinding machine, boring and milling machine, electrical discharge machine, etc.

UV-80

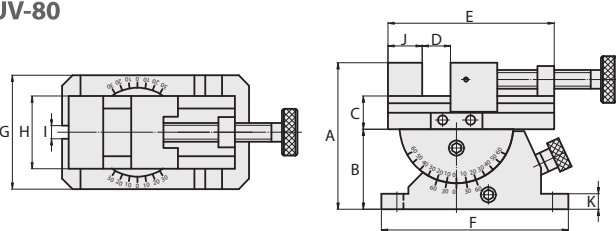

UV-120

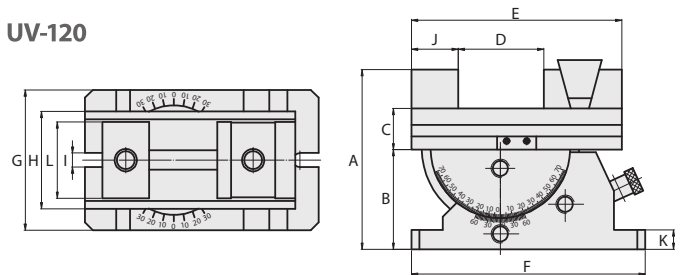

**SPECIFICATIONS** (Material: Vise: Steel / Base: FCD 50 Ductile Iron)

Unit: mm

Model	A	B	C	D	E	F	G	H	I	J	K	L	Weight (kg)
UV-80	137	75	32	78	160	180	110	70	16	32	15	-	12
UV-120	231	128	53	150	310	300	180	125	18	60	25	98	54